

DANIEL[®] LIQUID TURBINE METER USER MANUAL

SERIES 1200 LIQUID TURBINE METER
NPS 1 THROUGH 4



DANIEL[®]
Decades Proven. Field Chosen.[™]

CONTENTS

Part I	Plan	
Chapter 1	Introduction	3
	1.1 Purpose of this manual	3
	1.2 Hazard messages	3
	1.3 Personnel qualifications	3
	1.4 Warranty restrictions	5
	1.5 Assistance	5
	1.6 Description of the Series 1200 Liquid Turbine Meter (LTM)	5
	1.7 Agency certifications for the Series 1200 LTM	18
Chapter 2	Operating conditions and specifications	18
	2.1 Operating conditions for the liquid turbine meter	18
	2.2 Specifications for the LTM	22
Chapter 3	Turbine meter handling	25
	3.1 Receive the turbine meter	25
	3.2 Store the turbine meter	26
Chapter 4	Prepare the turbine meter for use	26
	4.1 Lifting conditions	26
	4.2 Lifting requirements for personnel	27
	4.3 Configuration of the turbine meter	29
Part II	Install	
Chapter 5	Installation prerequisites	33
	5.1 Pre-start checks	33
	5.2 Torque information	34
	5.3 Tools required for LME disassembly/assembly	34
Chapter 6	Installation procedure	34
	6.1 Cathodic protection	34
	6.2 Mechanical components assembly	34
	6.3 Assemble the electronic components.....	35
Chapter 7	Testing	36
	7.1 Test the turbine meter	36
Part III	Operate	
Chapter 8	Operation parameters	36
	8.1 Operation overview	36
	8.2 Turbine meter normal operation.....	37
	8.3 Back pressure calculation for the LTM	37

Part IV

Maintain

Chapter 9

Planned maintenance 37

9.1 Maintenance considerations 37

9.2 Tools required for mechanical components 38

9.3 Prepare for mechanical disassembly 38

9.4 Mechanical assembly 47

9.5 Electronics enclosure disassembly 56

9.6 Electronics enclosure assembly 57

9.7 Replace the preamplifier 57

9.8 Planned maintenance tasks 58

Chapter 10

Corrective maintenance 58

10.1 Turbine meter troubleshooting 58

10.2 Verify the return to operational condition 58

Chapter 11

Spare parts 59

11.1 Recommended spare parts..... 59

Chapter 12

Decommission the turbine meter 60

12.1 Shut down the turbine meter 60

12.2 Turbine meter disassembly/assembly 60

12.3 Shipment of the meter 61

PART I PLAN

1 INTRODUCTION

1.1 PURPOSE OF THIS MANUAL

Daniel designed this manual to guide owners and personnel through the installation, operation, and maintenance of the Daniel Series 1200 Liquid Turbine Meter Manual, 3-9008-513. It is imperative that product owners and operation personnel read and follow the information contained in this manual to ensure that the turbine meter is installed correctly and is operating according to the design, certifications and safety considerations.

1.2 HAZARD MESSAGES

This document uses the following criteria for hazard messages based on ANSI standards Z535.6-2011 (R2017).

 **DANGER**

Serious injury or death will occur if a hazardous situation is not avoided.

 **WARNING**

Serious injury or death could occur if a hazardous situation is not avoided.

 **CAUTION**

Minor or moderate injury will or could occur if a hazardous situation is not avoided.

NOTICE

Data loss, property damage, hardware damage, or software damage can occur if a situation is not avoided. There is no credible risk of physical injury.

Physical access

NOTICE

Unauthorized personnel can potentially cause significant damage and/or misconfiguration of end users' equipment. Protect against all intentional or unintentional unauthorized use. Physical security is an important part of any security program and fundamental to protecting your system. Restrict physical access to protect users' assets. This is true for all systems used within the facility.

1.3 PERSONNEL QUALIFICATIONS

Read and follow all instructions, dangers, warnings, and cautions to avoid personal injury or property damage during system operation. Daniel is not responsible for damage or injury resulting from unsafe use of products, lack of maintenance, incorrect installation of equipment or system operation. If in doubt about any applications and safety precautions described in this document, contact Daniel.

Inform and train all personnel in the proper installation, operation, and maintenance of this product. To ensure safe and proper performance, only informed and trained personnel should install, operate, repair and maintain this product. For further questions about training requirements, contact your local Daniel representative.

Operations risk assessment must be used and followed in conjunction with this document when performing all online retrieval operations.

Ensure that all end user and installation specific safety requirements are read, understood and adhered to.

Ensure that any operator that is conducting work on the equipment, is following end user guidelines on the use of protective equipment including, but not limited to:

- Safety helmet or hard hat
- Steel-toed shoes

- Safety glasses
- Working gloves (suitable for mechanical operations)
- Chemical resistant latex gloves or the equivalent
- Long-sleeved, fire-retardant shirt and fire-retardant trousers or full-length fire retardant coveralls

Additional PPE may be required depending on facility requirements and MSDS requirements, if applicable. Failure to comply may result in personnel injury.

⚠ WARNING
RISK TO PERSONNEL AND EQUIPMENT

Failure to follow the installation, operation or maintenance instructions for a Daniel product could lead to serious injury or death from explosion or exposure to dangerous substances. To reduce the risk:

- Comply with all information on the product, in this manual, and in any local and national codes that apply to this product.
- Do not allow untrained personnel to work with this product.
- Use Daniel parts and work procedures specified in this manual.

NOTICE

Observe all precautionary signs posted on the equipment to avoid serious injury.

⚠ WARNING
RISK TO PERSONNEL AND EQUIPMENT

Operation of this product on pressurized lines may potentially imply operational risk for personnel and equipment from the potential escape of hot gas or liquid, which could result in serious injury.

Observe all precautionary signs on the equipment.

⚠ WARNING
RISK TO PERSONNEL AND EQUIPMENT

The operation of the Daniel product involves heavy equipment handling. Observe the following guidelines to avoid potentially serious injury:

- Be aware of your limitations and ask for assistance if needed.
- Do not attempt to lift weight beyond your capacity.
- Lift with your legs, not your back.

NOTE

Mechanical lifting tools may also be used in some locations to reduce risk.

NOTICE

Attending the training course for this product is not considered sufficient for operating the tool on pressurized lines. Daniel requires a two-man crew with formal training.

Additionally, at least one of the operators must have a record of extensive field experience and be certified for this work.

Daniel assumes no responsibility for incidents, or consequences of incidents, occurring as a result of the use of this product by others than Daniel or its designated personnel, and have no liability whatsoever for any such work.

Consult Daniel for more details on both training and certification.

1.4 WARRANTY RESTRICTIONS

Visually inspect all components for shipping damage. If shipping damage is found, notify the carrier at once. Shipping damage is not covered by the warranty. The carrier is responsible for all repair and replacement costs resulting from shipment damage.

1.5 ASSISTANCE

The Daniel Global Service Center is organized through a network of service centers worldwide, and supports all service requirements or technical queries. For the Product Support Help Desk, go to: <http://www.Daniel.com> or contact your nearest Daniel service provider.

1.6 DESCRIPTION OF THE SERIES 1200 LIQUID TURBINE METER (LTM)

1.6.1 GENERAL FEATURES OF THE TURBINE METER

The Daniel Series 1200 Liquid Turbine Meter (LTM) is a volumetric flow metering and transmitting device used extensively in the petroleum industry for the accurate measurement of liquid hydrocarbons. The turbine meter's simple configuration ensures higher flow rates, extended flow range and sustained performance capability. This meter is specifically designed for loading rack service where a vital characteristic is repeatability.

The turbine meter is designed for use within the guidelines of API Manual of Petroleum Measurement Standards (MPMS), Chapter 5.3 and test procedures of API MPMS, Chapter 4 (Prover systems).

The meter consists of two main parts: Local Mounted Enclosure (LME) assembly and the meter body housing assembly.

The LME is an explosion-proof, weather-resistant housing for dual pickoffs, as well as an encapsulated preamplifier. It also serves as the mechanical mounting connection necessary for local and remote accessories.

NOTE

Daniel offers electronic enclosures with different housing materials and electronic configurations.

Local Mounted Enclosure (LME)

The LME consists of an electrical enclosure and a solid cover made of stainless steel. This configuration contains a mounting bracket and a preamplifier which works with two standard pickoff coils mounted into the meter housing.

The electrical enclosure contains an external and an internal grounding lug. The two enclosure openings are plugged with stainless steel plugs. Refer to Operating conditions and specifications for more specifications.

1.6.2 OPERATION OVERVIEW OF THE TURBINE METER

Metering systems combine turbine meters and electronic instrumentation to measure volumetric total flow and/or flow rate. Metering systems are used to provide measurement information in fluid transport, petroleum and chemical processing, custody transfer of liquids, blending systems, in product batching and in field or plant operations.

- Each turbine meter is comprised of a cylindrical housing that contains a precise turbine rotor assembly. The magnetic pickoffs are mounted in a boss on the turbine meter body.
- As fluid passes through the turbine meter, it causes the rotor to revolve with an angular velocity proportional to flow.
- The rotor blades passing through the magnetic field of the pickoff generate a pulsing voltage in the coil of the pickoff assembly. Each voltage pulse represents a discrete volume. The total number of pulses collected over a period of time represents the total volume metered.
- The sinusoidal signal from each pickoff has a low amplitude and is not normally relied upon for transmission distances over 6 meters (20 feet). The signal must, therefore, be amplified. This is achieved with a preamplifier contained within the LME that is mounted on the turbine meter.

- These pulse signals are typically transmitted to control room instrumentation, such as flow computers, and may also be required to transmit to prover computers which calculate, display, transmit, control or record the flow sensed by the rotor. The results may be displayed as pulse-counts or standard engineering units, such as gallons, liters, barrels, etc.
- All Daniel Series 1200 Liquid Turbine Meters have, as standard, the LME which is fitted with two pick-offs and a dual channel preamplifier.
- The pickoff mountings are oriented so that the outputs from the pickups are 90° electrically out of phase.
- Each turbine meter is precisely flow calibrated before shipment.

1.6.3

PARTS LISTS FOR THE SERIES 1200 LTM, NOMINAL PIPE SIZE (NPS) 1-4

This section includes the necessary parts required to assemble a standard unit described in this manual.

Configuration for LME assembly - Standard enclosure is shown below.

LME ASSEMBLY - STANDARD ENCLOSURE

FIGURE 1-1: PART IDENTIFICATION FOR A STANDARD ENCLOSURE

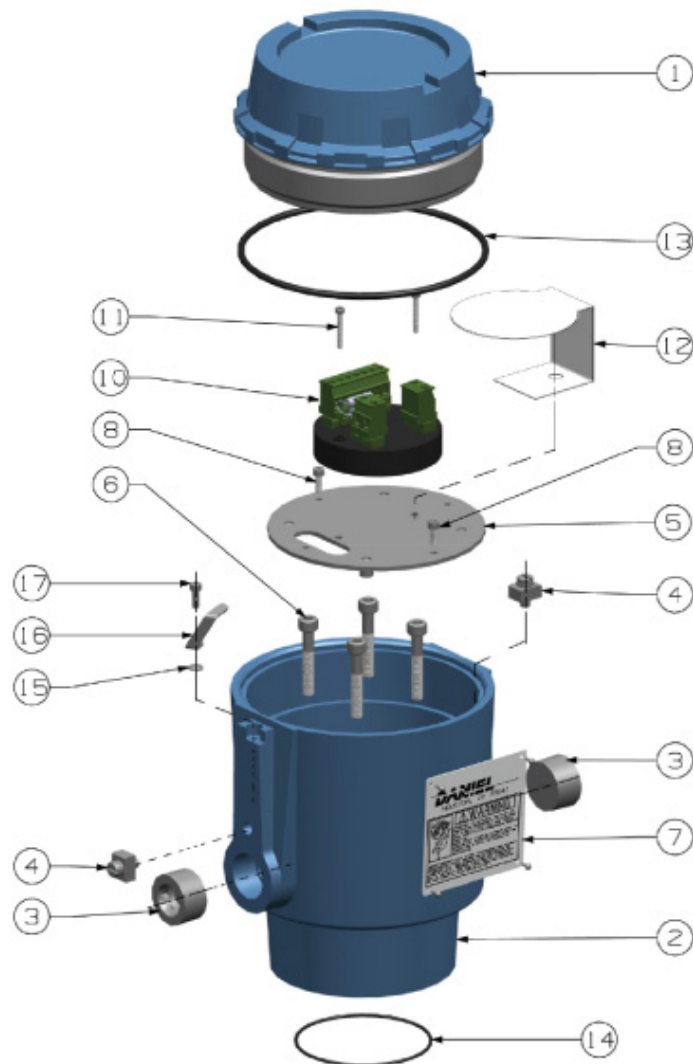

TABLE 1-1: PART DESCRIPTION FOR A STANDARD ENCLOSURE

Item number	Description	Part number	Quantity required
1 ⁽¹⁾	End cap solid	1-360-00-025	1
2 ⁽¹⁾	Electronics enclosure	899-10-110-60	1
3	Plug pipe hex socket	154717-019	2
4	Grounding clamp	B18934-004	2
5	Mounting bracket	899-10-230-50	1
6 ⁽²⁾	Socket head screw	899-10-230-52	4
7	Warning tag-Hazard	899-00-228-04	1
8	Socket head screw	899-10-230-61	2
10 ⁽³⁾	2818 Dual channel preamplifier	1-504-05-550	1
11	Socket head screw	899-10-230-65	2
12	Wiring diagram for 2818 Dual channel preamplifier	899-10-228-07	1
13	O-ring NBR	2-4-9163-245	1
14	O-ring FKM	1500093-022	1
15	Washer plastic	1-562-01-827	1
16	Clamp cover	1-504-90-165	1
17	Socket head screw	1-555-27-001	1

(1) Enclosure housing and end cap material: stainless steel.

(2) Screw length varies on LTM sizes. The screws are not included in the part number package.

(3) 2818 Dual channel shown. For other preamplifier options refer to Interface parameters.

NOTICE

The joint between the LME cover and housing is a threaded joint. The joint between the LME housing and Sensor housing is a spigot joint with a minimum axial length of 26.16 mm (1.030 in), radial length of 3.18 mm (0.125 in), and a clearance of 0.07 mm (0.0028 in).

LME ASSEMBLY - INTERNAL TOTALIZER

FIGURE 1-2: PART IDENTIFICATION FOR THE LME WITH INTERNAL TOTALIZER

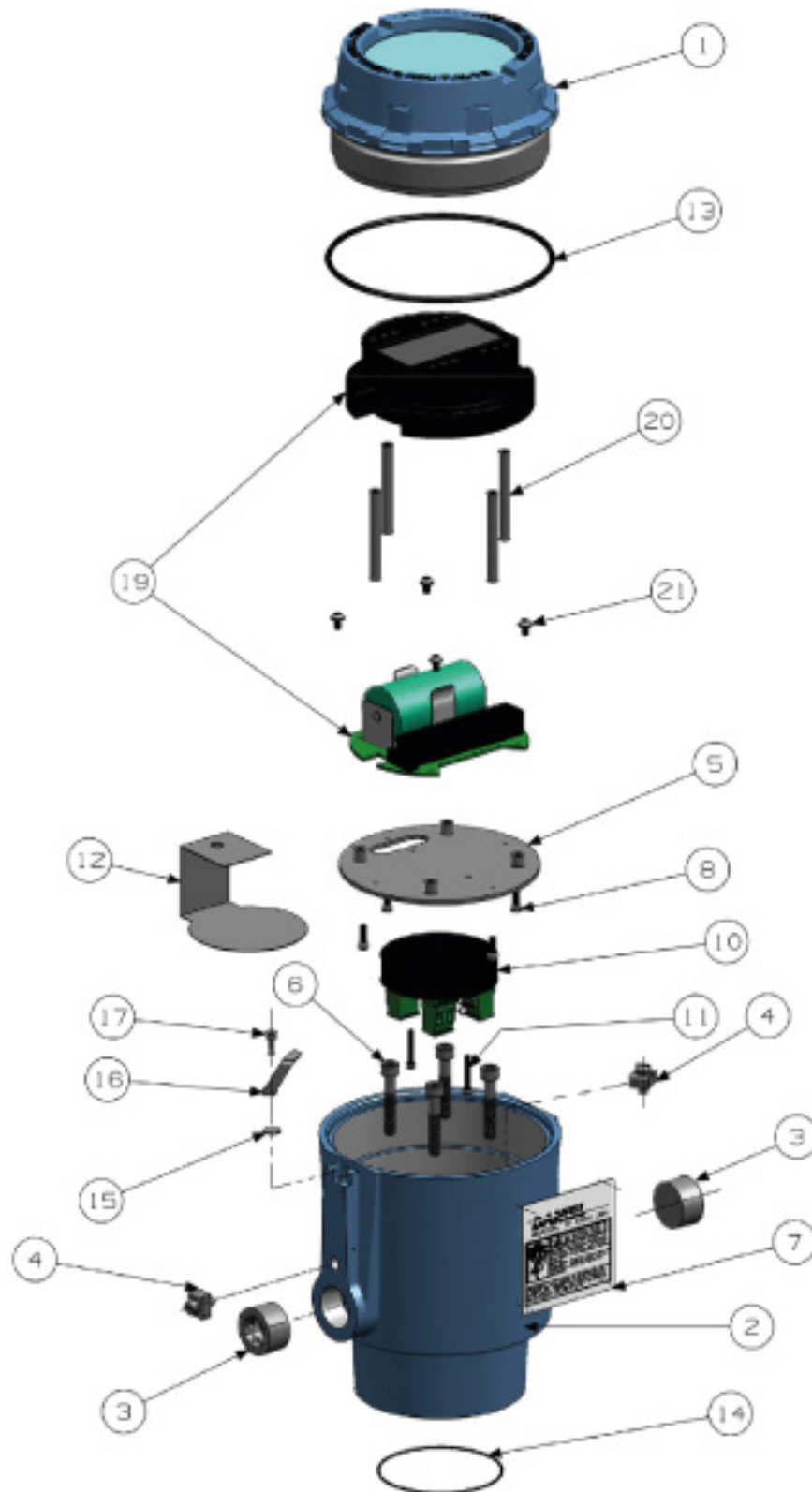

TABLE 1-2: PART DESCRIPTION FOR THE LME WITH INTERNAL TOTALIZER

Item number	Description	Part number	Quantity required
1(1)	Cover (SS/ALUM)	899-10-230-60/70	1
2	Electronics enclosure (SS/ALUM)	899-10-110-60/70	1
3	Plug pipe hex socket	154717-019	2
4	Grounding cap	B18934-004	2
5	Mounting bracket	899-10-230-50	1
6(2)	Socket head screw	899-10-230-52	4
7	Warning tag-Hazard	899-00-328-04	1
8	Socket head screw	899-10-230-61	4
10	2818 Dual channel preamplifier	1-504-05-550	1
11	Socket head screw	899-10-230-65	2
12	Wiring diagram for 2818 Dual channel preamplifier	899-10-230-69	1
13	O-ring NBR	2-4-9163-245	1
14	O-ring FKM	1500093-022	1
15	Washer plastic	1-562-01-827	1
16	Clamp cover	1-504-90-165	1
17	Socket head screw	1-555-27-001	1
19	Display and terminal block	899-10-230-30/32	1
20	Female standoff	899-10-230-63	4
21	Machine screw	899-10-230-64	4

(1) Enclosure housing and cap material: aluminum. Optional: stainless steel.

(2) Screw length varies on LTM sizes. The screws are not included within the part number package.

NOTICE

The joint between the LME cover and housing is a threaded joint. The joint between the LME housing and sensor housing is a cylindrical joint which has an axial length of 25.4 mm (1 in) and a clearance of 0.038 mm (0.0015 in).

METER HOUSING INTERNAL COMPONENTS - NPS 1

The information below identifies and describes the NPS 1 meter housing components.

FIGURE 1-3: PART IDENTIFICATION FOR AN NPS 1 LTM

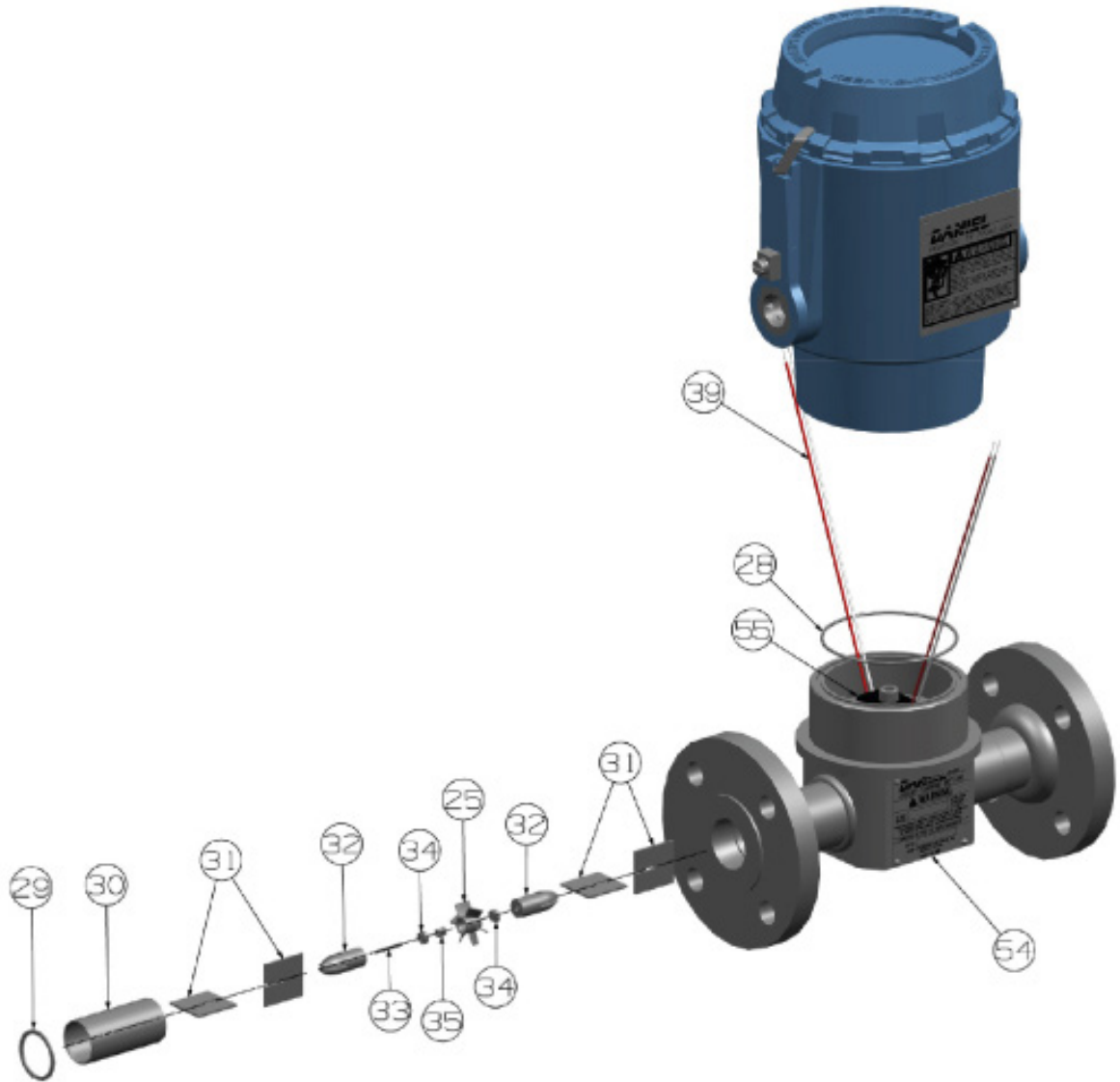

TABLE 1-3: PART DESCRIPTION FOR AN NPS 1 LTM

Item number	Description	Part number	Quantity required	
25	Rotor	798-10-019-00	1	
28	O-Ring	1500093-022	1	
29	Clip	1-504-05-520	1	
30	Sleeve	797-10-500-60	1	
31	Hanger blade	798-10-080-00	4	
32	Hanger hub	798-10-008-00	2	
33	Shaft	798-10-018-00	1	
34	Bearing	1505024	2	
35	Spacer	798-10-073-00	1	
39	Pickoff	899-00-201-00	2	
54	Meter housing	Class 150	799-10-311-61M	1
		Class 300	799-10-331-61M	1
55	Anti-rotation bracket clamp	899-10-230-66	1	

NOTE

For alternative materials and NACE, contact Daniel Sales and Service.

METER HOUSING INTERNAL COMPONENTS - NPS 1.5 THROUGH 2

The information below identifies and describes the NPS 1.5 through 2 meter housing components.

FIGURE 1-4: PART IDENTIFICATION FOR AN NPS 1.5 THROUGH 2 LTM



TABLE 1-4: PART DESCRIPTION FOR AN NPS 1.5 LTM

Item number	Description	Part number for material 304 SS	Quantity required	
18	Nut	151687	1	
19	Washer	151891	1	
20	Flow conditioning plate	798-14-301-01	1	
21	Hanger blade	798-14-070-00	3	
22	Hanger hub	798-14-308-00	1	
23	Bearing	155195	2	
24	Spacer	798-14-073-00	1	
25	Rotor	798-14-019-00	1	
26	Downstream cone	798-14-013-00	1	
28	O-ring	1500093-022	1	
39	Pickoff	899-00-201-00	2	
54	Meter housing	Class 150	798-14-312-61M	1
		Class 300	798-14-332-61M	1
55	Anti-rotation bracket clamp	899-10-230-66	1	

TABLE 1-5: PART DESCRIPTION FOR AN NPS 2 LTM

Item number	Description	Part number for material 304 SS	Quantity required	
18	Nut	151687	1	
19	Washer	151891	1	
20	Flow conditioning plate	798-16-301-01	1	
21	Hanger blade	798-16-070-00	3	
22	Hanger hub	798-16-308-00	1	
23	Bearing	155195	2	
24	Spacer	798-14-073-00	1	
25	Rotor	798-16-019-00	1	
26	Downstream cone	798-16-013-00	1	
28	O-ring	1500093-022	1	
39	Pickoff	899-00-201-00	2	
54	Meter housing	Class 150	798-16-312-61M	1
		Class 300	798-16-332-61M	1
55	Anti-rotation bracket clamp	899-10-230-66	1	

NOTE

For alternative materials and NACE, contact Daniel Sales and Service.

METER HOUSING INTERNAL COMPONENTS - NPS 3 THROUGH 4 - STAINLESS STEEL BEARING INTERNALS

The information below identifies and describes the NPS 3 through 4 stainless steel meter housing components.

FIGURE 1-5: PART IDENTIFICATION FOR AN NPS 3 THROUGH 4 LTM - STAINLESS STEEL BEARING INTERNALS

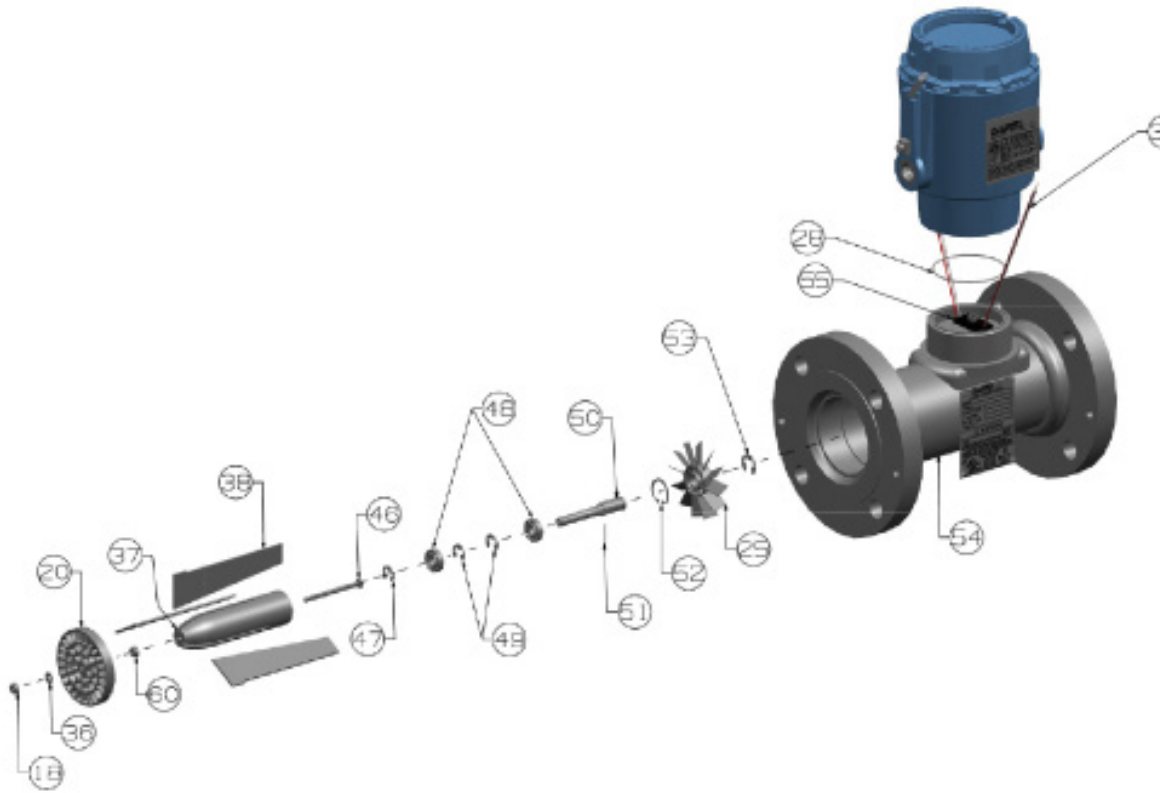

TABLE 1-6: PART DESCRIPTION FOR AN NPS 3 LTM - STAINLESS STEEL BEARING INTERNALS

Item number	Description	Part number for material 304 SS	Quantity required	
18	Nut	151687	2	
20	Flow Conditioning Plate - Thermoplastic	798-20-301-01	1	
20	Flow Conditioning Plate - Aluminum	798-20-301-02	1	
25	Rotor assembly	798-20-319-00	1	
28	O-ring	1500093-022	1	
36	Washer	151891	1	
37	Diffuser	798-20-008-00	1	
38	Support fin	798-20-070-00	3	
39	Pickoff	899-00-201-00	2	
46	Screw (hex head)	1500615	1	
47	Retaining ring (External)	156514	1	
48	Ball Bearing	155194	2	
49	Retaining Ring (External, Bowed)	1500733	2	
50	Shaft	798-20-010-00	1	
51	Roll pin	153569	1	
52	Retaining ring	1500616	1	
53	Retaining Ring (External)	1500732	1	
54	Meter housing	Class 150	798-20-312-61M	1
		Class 300	798-20-332-61M	1
55	Anti-rotation bracket clamp	899-10-230-66	1	

TABLE 1-7: PART DESCRIPTION FOR AN NPS 4 LTM - STAINLESS STEEL BEARING INTERNALS

Item number	Description	Part number for material 304 SS	Quantity required	
18	Nut	151685	2	
20	Flow Conditioning Plate - Thermoplastic	798-22-301-01	1	
20	Flow Conditioning Plate - Aluminum	788-22-301-02	1	
25	Rotor assembly	798-22-319-00	1	
28	O-ring	1500093-022	1	
36	Washer	151857-419	1	
37	Diffuser	798-22-008-00	1	
38	Support fin	798-22-070-00	3	
39	Pickoff	899-00-201-00	2	
46	Screw (hex head)	150739-419	1	
47	Retaining ring (External)	1500732	1	
48	Ball Bearing	159641	2	
49	Retaining Ring (External, Bowed)	1500735	2	
50	Shaft	798-22-010-00	1	
51	Roll pin	153505-419	1	
52	Retaining ring	1500617	1	
53	Retaining Ring (External)	1500734	1	
54	Meter housing	Class 150	798-22-312-61M	1
		Class 300	798-22-332-61M	1
55	Anti-rotation bracket clamp	899-10-230-66	1	

NOTE

For alternative materials and NACE, contact Daniel Sales and Service.

METER HOUSING INTERNAL COMPONENTS - NPS 3 THROUGH 4 - TUNGSTEN CARBIDE BEARING INTERNALS

The information below identifies and describes the NPS 3 through 4 tungsten carbide meter housing components.

FIGURE 1-6: PART IDENTIFICATION FOR AN NPS 3 THROUGH 4 LTM - TUNGSTEN CARBIDE BEARING INTERNALS

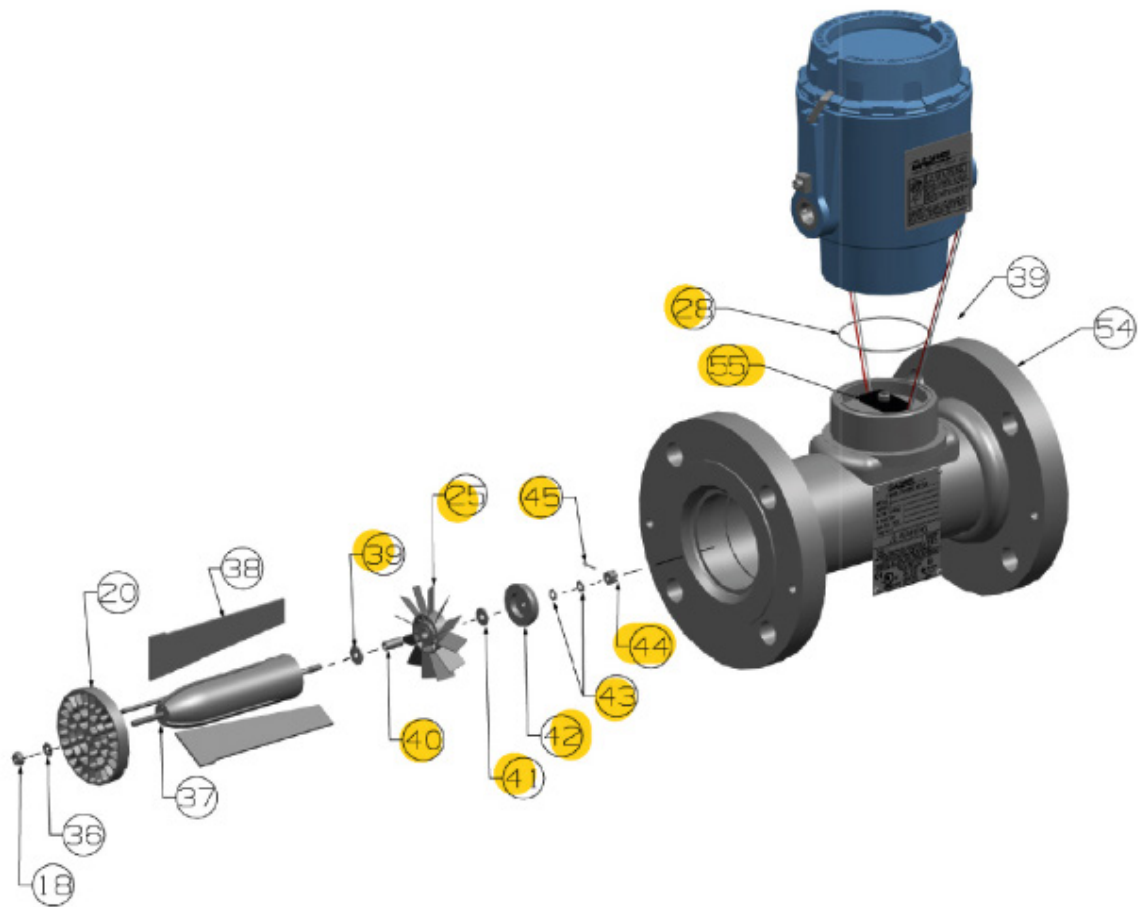

TABLE 1-8: PART DESCRIPTION FOR AN NPS 3 LTM -TUNGSTEN CARBIDE BEARING INTERNALS

Item number	Description	Part number for material 304 SS	Quantity required	
18	Nut	151687	1	
20	Flow Conditioning Plate - Thermoplastic	798-20-301-01	1	
20	Flow Conditioning Plate - Aluminum	798-20-301-02	1	
25	Rotor assembly	798-20-319-01	1	
28	O-ring	1500093-022	1	
36	Washer	151891	1	
37	Diffuser	798-20-390-00	1	
38	Support fin	798-20-070-00	3	
39	Pickoff	899-00-201-00	2	
40	Shaft sleeve	894-22-073-00	1	
41	Thrust washer	894-22-062-00	2	
42	Outlet diffuser cap	798-20-013-00	1	
43	Belleville washer	1500422	2	
44	Nut	151650	1	
45	Cotter pin	153930	1	
54	Meter housing	Class 150	798-20-312-61M	1
		Class 300	798-20-332-61M	1
55	Anti-rotation bracket clamp	899-10-230-66	1	

TABLE 1-9: PART DESCRIPTION FOR AN NPS 4 LTM -TUNGSTEN CARBIDE BEARING INTERNALS

Item number	Description	Part number for material 304 SS	Quantity required	
18	Nut	151685	1	
20	Flow Conditioning Plate - Thermoplastic	798-22-301-01	1	
20	Flow Conditioning Plate - Aluminum	788-22-301-02	1	
25	Rotor assembly	798-22-319-01	1	
28	O-ring	1500093-022	1	
36	Washer	151891	1	
37	Diffuser	798-22-390-00	1	
38	Support fin	798-22-070-00	3	
39	Pickoff	899-00-201-00	2	
40	Shaft sleeve	894-22-073-00	1	
41	Thrust washer	894-22-062-00	2	
42	Outlet diffuser cap	798-22-013-00	1	
43	Belleville washer	1500422	2	
44	Nut	151650	1	
45	Cotter pin	153930	1	
54	Meter housing	Class 150	798-22-312-61M	1
		Class 300	798-22-332-61M	1
55	Anti-rotation bracket clamp	899-10-230-66	1	

NOTE

For alternative materials and NACE, contact Daniel Sales and Service.

1.7 AGENCY CERTIFICATIONS FOR THE SERIES 1200 LTM

The following are product agency certifications applicable to the Daniel Series 1200 LTM.

TABLE 1-10: AGENCY CERTIFICATIONS FOR THE SERIES 1200 LTM

Certification type		Description	Certificate
Electrical	UL and CUL	Class I, Div. 1, Groups B, C & D	E202815
	ATEX	Ⓢ II 2 G Ex db IIB T6 Gb Ⓢ II 2 G Ex db IIC T6 Gb	DEMKO 03 ATEX 130946X Rev. 10
	IECEX	Ex db IIB T6 Gb Ex db IIC T6 Gb	IECEX UL 11.0031X Rev 10
	INMETRO	Ex db IIC T6 Gb	NCC 23.0046 X rev 0
Environmental		NEMA 4x (IP66).	DEMKO 03 ATEX 130946X Rev. 10
Metrology		MID / OIML R117-1	TC7573 Rev. 6
Pressure Equipment	PED	Pressure Equipment Directive	CE 828337
	PESR	Pressure Equipment (Safety) Regulations	UKCA 828334
Ambient temperature		-40 °C to 60 °C (-40 °F to 140 °F)	

2 OPERATING CONDITIONS AND SPECIFICATIONS

2.1 OPERATING CONDITIONS FOR THE LIQUID TURBINE METER

TABLE 2-1: OPERATING CONDITIONS FOR THE LIQUID TURBINE METER

Parameter type	Description
Fluid phase	Liquid.
Fluid(s) measured	<ul style="list-style-type: none"> Low viscosity crude oils and condensates. Refined products and intermediates (e.g.: gasoline, diesel, kerosene, light fuel oils, jet fuel, LPG, butanes, naphtha, alkylate, reformat, straight run gasoline, catcracked gasoline). Petrochemicals (e.g.: benzene, toluene, xylenes, cumene, olefins, pyrolysis gasoline). Natural gas liquids.
Process temperature (Carbon steel flanges)	-29 °C to 60 °C (-20 °F to 140 °F).
Process temperature (Stainless steel flanges)	-40 °C to 60 °C (-40 °F to 140 °F).
Fluid static pressure	The maximum working pressure for the Daniel Series 1200 Liquid Turbine Meter is based on the temperature/pressure rating of the ANSI B16.5 flanges. For maximum working pressures at intermediate temperatures refer to ANSI B16.5.
Ambient temperature	-40 °C to 60 °C (-40 °F to 140 °F) (Tamb is an electrical specification).

2.1.1 DESIGN CONSIDERATIONS

Some conditions to consider:

- Service operating pressure
- Service testing pressures
- Service process temperature and ambient site temperatures
- Chemical composition and fluid toxicity in operating conditions

- Traffic, wind and earthquake at loading site
- Adverse force or stress caused by inadequate supports, attachments, piping, etc.
- Corrosion, erosion, fatigue, etc.
- Decomposition of unstable fluids in operating and test conditions
- Possible damage from external fire
- Mass of fluid in process and test conditions

⚠ WARNING
FUNCTIONAL AND ENVIRONMENTAL HAZARD

Evaluate the functional and environmental conditions prior to installing a turbine meter. Install the turbine meter in a well designed piping system.

Failure to comply may result in death or serious injury.

2.1.2 ENVIRONMENTAL CONDITIONS

⚠ WARNING
EQUIPMENT HAZARD

Never use this equipment for any purpose other than its intended use.

Failure to comply may result in death, serious injury and/or property damage.

TABLE 2-2: ENVIRONMENTAL CONDITIONS	
Parameter type	Description
Maximum working pressure	This is based on the temperature and pressure rating of the ANSI B16.5 flanges.
Maximum working pressure	Ensure that piping or other attachments connected to the turbine meter are not under stress. The design of the turbine meter has not been assessed for the effects of wind, earthquake loading and/or other severe weather conditions.
Corrosive service	Select the material compatible with specific processes and atmospheric environments. Implement a periodic inspection and maintenance program to ensure that pressure-retaining components are free from corrosion and erosion.
Low and freezing temperatures	Low specific gravities or high viscosities reduce the flow range of the turbine meter. Refer to Operating parameters for the LTM for more information.
Populated areas	For new installations, locate the turbine meter to an area that has fewer than 10 buildings intended for human occupancy, within an area that extends 200 meters (220 yards) radially from the turbine meter. (Reference: Class 1 location. U.S. DOT, CFR Title 49: Part 192.5)
Closed, poorly ventilated areas and combustion sources	Install the turbine meter in a well ventilated area, not less than one meter (approximately 3 feet) from source of ignition or source of heat which might damage the unit.
Elevation	No limit.
Humidity	No limit.
Proximity to open flame	Provide fire prevention measures and equipment per local regulations.
Proximity to vehicular traffic	The design of the turbine meter has not been assessed for the effects of traffic loads.

2.1.3 OPERATING PARAMETERS FOR THE LTM

Turbulent flow is detrimental and affects turbine meter linearity(1). It can cause nonhomogeneous fluid cross-section and inconsistent back pressure, possibly resulting in cavitation(2). To correct the flow characteristics, use upstream and downstream piping lengths per Figure 2-3).

Pipe fittings such as elbows and tees, and piping components such as valves and strainers should be located far enough upstream to dissipate any flow disturbance before it reaches the turbine meter. The use of flow straighteners or a flow conditioning plate greatly influences turbine meter performance.

Specific gravity

The turbine meter is affected by specific gravity which may influence performance. The effect of specific gravity on the turbine meter may be evidenced when it is below 0.7. As specific gravity decreases, the lift forces on the turbine blade decreases. Likewise as velocity decreases, lift forces decrease. These reduced lift forces are overtaken by bearing friction as low rates are approached. Subsequently, linearity deteriorates at low flow rates while measuring light fluids.

Viscosity

Turbine meters are viscosity sensitive. As the metered fluid increases in viscosity, meter linearity declines. This effect on linearity is primarily due to a change in the fluid’s velocity profile and skin friction between the fluid and the rotor blades.

Viscosities of 3 centipoise or less are seldom cause for concern. Consider all influential factors of higher levels. By anticipating the viscosity, maximum flow rate, flow range and desired linearity of the flow system, the user is able to determine the appropriate turbine meter for the application.

Back pressure

Maintain sufficient back pressure on the turbine meter to prevent flashing and cavitation. This is particularly important when measuring liquids with high vapor pressures, such as LPGs.

EQUATION 2-1: BACK PRESSURE CALCULATION

$$P_b \geq 2\Delta p + 1.25p_e$$

(1) Linearity is the total range of deviation of accuracy, expressed as a curve, between minimum and maximum flow rates.

(2) Cavitation is the formation and collapse of vapor-filled cavities that result from a sudden decrease and increase in pressure. Refer to Back pressure calculation for more information.

P_b = Minimum back pressure, pounds per square inch gauge (psig)

Δp = Pressure drop through the meter at the maximum operating flow rate for the liquid being measured, pounds per square inch (psi).

P_e = Equilibrium vapor pressure of the liquid at the operating temperature, pounds per square inch absolute (psia), gauge pressure plus atmospheric pressure.

Figure 2-1 illustrates the effects of back pressure. Insufficient back pressure leads to measurement inaccuracy. The resulting flashing and cavitation are extremely damaging to the flow meter and pipework.

FIGURE 2-1: EFFECTS OF BACK PRESSURE

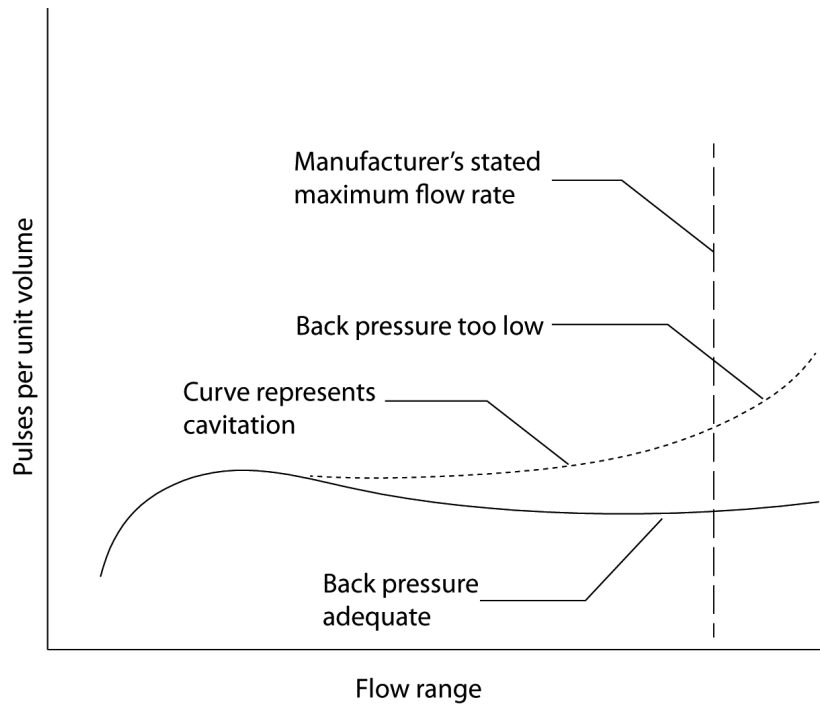

Back pressure calculation

EQUATION 2-2: BACK PRESSURE CALCULATION

$$P_b \geq 2\Delta p + 1.25p_e$$

P_b = Minimum back pressure, pounds per square inch gauge (psig)

Δp = Pressure drop through the meter at the maximum operating flow rate for the liquid being measured, pounds per square inch (psi).

P_e = Equilibrium vapor pressure of the liquid at the operating temperature, pounds per square inch absolute (psia), gauge pressure plus atmospheric pressure.

Additional devices for accurate measurement

Valves

The metering system should have a flow rate control valve located at a convenient distance downstream of all measurement equipment. The function of the control valve is to limit and maintain system pressure on the meter. This avoids cavitation.

Valves should be capable of rapid, smooth opening and closing with positive shut-off.

- When used for intermittent flow, valves should be fast-acting and shock-free.
- Bypass lines should be equipped with blind or positive shutoff devices.
- Shut-off or control valves should be located downstream of the turbine meter.

Flow straightening devices

For accurate operation of the turbine meter, a flow conditioning plate, flow straightener (designed for the turbine meter), or a straight run of pipe (20 pipe diameters long) is required. All piping must be the same diameter as the turbine meter. Flow straightening devices must be installed directly upstream of the turbine meter and should not contain flow restricting devices which could cause reversal of the flow straightening effect.

Strainers

Install the correct size strainer upstream of the turbine meter to protect it from foreign material damage. Recommended mesh sizes include: 80 mesh for refined products, and 20 to 40 mesh for crude products (depending on the product being measured).

Clean the strainer basket regularly, to prevent filling and rupturing of the screen.

Pressure gauges installed on both sides of the strainer monitor differential pressure across the strainer. High pressure differential caused by filling of the basket or occlusion of foreign material can cause a strainer basket rupture, resulting in possible turbine meter damage.

2.2 Specifications for the LTM
2.2.1 INTERFACE PARAMETERS

⚠ WARNING
EXCEEDING PARAMETER HAZARD

Turbine meter parameters are set for safe equipment use. Do not exceed these parameters.

Failure to comply may result in death, serious injury and/or damage to the equipment.

TABLE 2-3: 2818 DUAL CHANNEL PREAMPLIFIER PERFORMANCE

Parameter type	Description
Inputs	Supply voltage: 10-30 VDC Sensor type: Reluctance. Signal: Sine wave. Preamplifier sensitivity: 40 mV peak to peak minimum. Temperature range: -40 °C to 85 °C (-40 °F to 185 °F).
Outputs	Powered pulse output: <ul style="list-style-type: none"> • Type: Square wave. • Frequency range: 0 to 5 kHz. • Amplitude: 0 to 5 V. • 1000 Ohm internal pull-ups, 20 mA, max.
	Variable voltage output: <ul style="list-style-type: none"> • Type: Square wave. • Frequency range: 0 to 5 kHz. • Amplitude: 0 to Supply voltage. • 1000 Ohm internal pull-ups, 70 mA, max.
Construction	Delrin housing Solid epoxy encapsulation

Wiring and cable connections

The pickoff input signal connections are made at terminal strip connection TB2 for Channel A, and TB3 for Channel B. Power supply and output signal connections are made at terminal strip TB1. Refer to Table 2-4.

IMPORTANT

- For single channel wiring use multi-conductor control and instrumentation cable (18AWG), or equivalent.
- Earth ground shield at one end only.

IMPORTANT

- Insulate the shield at the other end.
- For dual channel wiring use multi-conductor control and instrumentation cable (18AWG), or equivalent.
- Connect both shields to earth ground at one end of the cables and insulate the shields at the other end.
- The LME housing should be at earth ground.

TABLE 2-4: 2818 DUAL CHANNEL PREAMPLIFIER CONFIGURATION

Plug component designator	Terminal connections	Description
TB1 - Customer connection	1	+10 to 30 Vdc
	2	Common
	3	Common
	4	Channel A output
	5	Channel B output
	6	TTL out A
	7	TTL out B
TB2 - Channel A pickoff (1)	1	White
	2	Red
TB3 - Channel B pickoff (1)	1	White
	2	Red

Pickoff coils

The Series 1200 LTM has the capacity for dual pickoff coils mounted 90° electrically out of phase. Each pickoff produces a low level sine wave signal which varies in amplitude (mV) and frequency (Hz) proportional to the velocity of the turbine blades. This signal information is coupled to the input terminals of the preamplifier.

Induced interference

The LTM should be located as far as possible from any electrical equipment such as motors, solenoids or relays which could induce an interference signal into the turbine meter pickoff coil. High amplitude interference introduced into the preamplifier can result in interference with the flow signal. Proper shielding and an earth grounded LME housing will greatly reduce the possibility of induced interference.

Accessory hookup

It is important that the correct service manual be referenced before attempting to use accessories or instrumentation with the Series 1200 LTM. Contact the factory or nearest Daniel service office if service manuals were not received at the time of purchase or delivery.

LTM flange type

The mechanical connections for a Series 1200 LTM NPS 1 through 4 are standard class 150 and 300 ANSI S.O. R.F. flanges, which are available in stainless steel and carbon. Other types of flange connections are available per customer request. For other ANSI ratings or flanges consult the factory engineers. For maximum working pressures at intermediate temperatures refer to ANSI B16.5.

**⚠ WARNING
HIGH PRESSURE HAZARD**

Choose the appropriate size and material of the flange for their piping requirements.

Choosing an incorrect flange may cause a pressure leak, resulting in death or serious injury.

2.2.2 Requirements and limitations for installation

FIGURE 2-2: TYPICAL INSTALLATION FOR A SERIES 1200 LTM

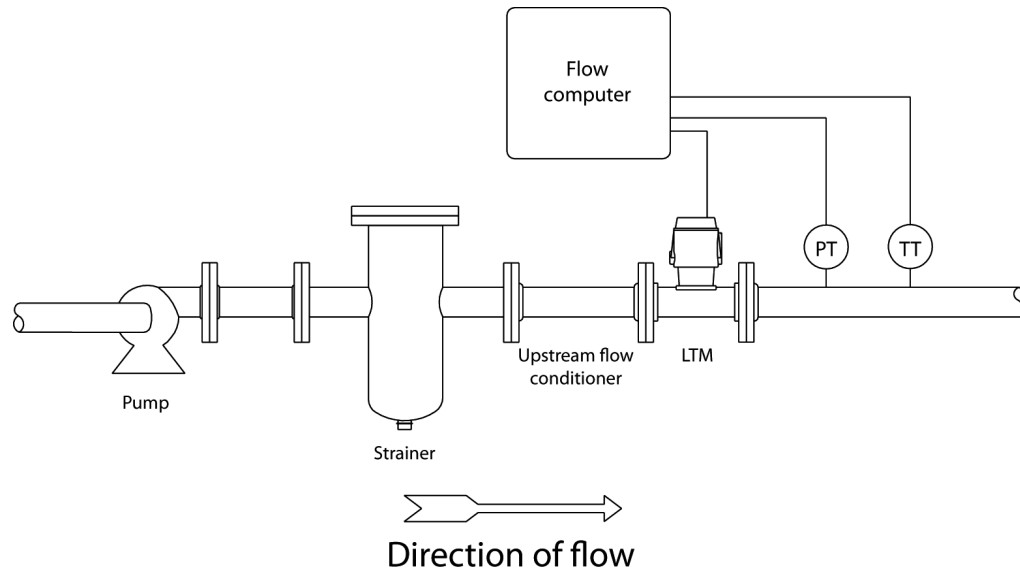

- Note the direction of flow indicated on the plate near the inlet flange and install accordingly.
- New installations: Flush lines thoroughly to rid piping of potentially damaging foreign material such as welding bead, pipe scale, etc. before the turbine meter is placed into service.

IMPORTANT

A spool piece installed in place of the turbine meter is recommended for this procedure.

NOTICE

Comply with local government regulations and company requirements.

Minimum clearances for installation, operation and maintenance

Below is the approximate shipping dimensions and weight for the Series 1200 LTM NPS 1-4. For certified dimension prints, please consult the factory.

FIGURE 2-3: DIMENSIONS FOR THE SERIES 1200 LTM NPS 1-4

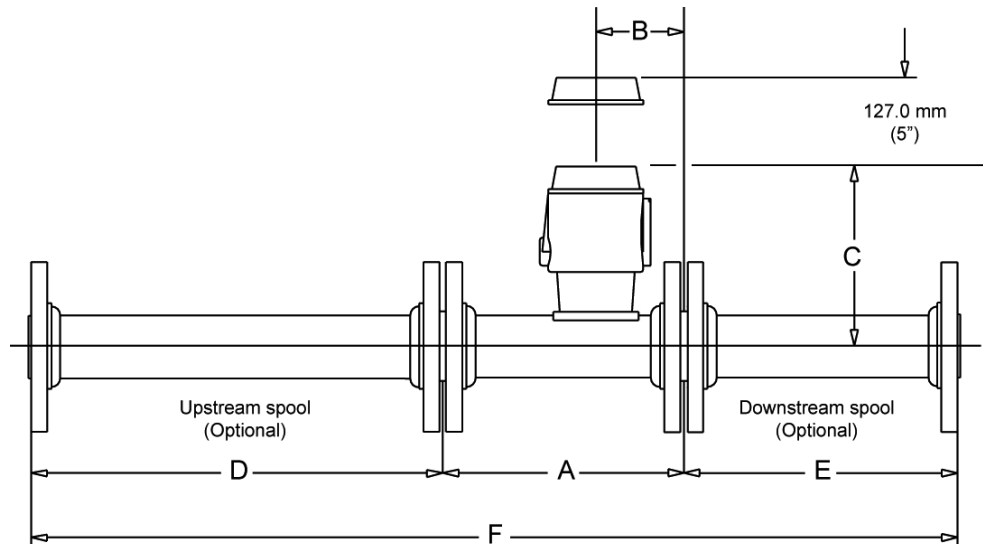

TABLE 2-5: FLOW METER AND FLOW STRAIGHTENING SECTION DIMENSIONS FOR THE SERIES 1200 LTM NPS 1-4

Size	A		B		C	
	Inches	mm	Inches	mm	Inches	mm
1	8	203	4	102	10	260
1.5	9	229	4.5	114	11	269
2	9	229	4.5	114	11	269
3	10	254	5	127	11	279
4	12	305	6	152	12	298

TABLE 2-6: FLOW METER AND FLOW STRAIGHTENING SECTION DIMENSIONS FOR THE SERIES 1200 LTM NPS 1-4

Size	A		B		C	
	Inches	mm	Inches	mm	Inches	mm
1	N/A	N/A	N/A	N/A	N/A	N/A
1.5	N/A	N/A	N/A	N/A	N/A	N/A
2	20	508	10	254	39	991
3	30	762	15	381	55	1397
4	40	1016	20	508	72	1397

TABLE 2-7: WEIGHT TABLE FOR THE STAINLESS STEEL LME

Size	ANSI class 150		ANSI class 300	
	Lbs	Kg	Lbs	Kg
1	23	11	23	11
1.5	26	12	32	15
2	30	14	32	15
3	42	19	51	23
4	57	26	74	34

3 TURBINE METER HANDLING

3.1 RECEIVE THE TURBINE METER

**⚠ WARNING
EQUIPMENT HANDLING AND OPERATING HAZARD**

Wear personal protective equipment appropriate to the situation when working with the turbine meter. Adhere to all safety standards and best practices for operating the equipment.

Failure to comply may result in death or serious injury.

3.1.1 UNPACK AND INSPECT THE TURBINE METER

Inspect the turbine meter upon receiving at the customer facility.

Procedure

1. Remove the turbine meter from the shipping container.
2. Inspect the turbine meter for damage.
3. See Installation procedure for Installation procedure.

3.2 STORE THE TURBINE METER

3.2.1 RUST INHIBITOR

Apply light oil or rust inhibitor on surfaces that are in contact with the environment only if the turbine meter body is carbon steel.

3.2.2 PACK THE TURBINE METER

Procedure

1. Use stretch wrap (not adhesive) to attach the correct size flange cover to the turbine meter end flanges. This protects the unpainted surfaces of the flange sealing.
2. A flush contact between the flange cover and the flange sealing face is important.

3.2.3 STORAGE CONDITIONS

Store the turbine meter in a safe area to avoid damage.

**⚠ WARNING
CRUSHING HAZARD**

During turbine meter installation or removal, always place the unit on a stable platform or surface that supports its assembled weight.

Failure to comply could allow the turbine meter to roll, resulting in death, serious injury or equipment damage.

TABLE 3-1: METER STORAGE CONDITIONS

Parameter type	Description
Storage environment	For long term storage, it is recommended that the complete meter housing assembly be stored under cover in a controlled environmental atmosphere in the original packaging. The storage temperature limits are -40 °C to 60 °C (-40 °F to 140 °F).
Shelf life for elastomers	Elastomers are only installed in a flameproof pad and a threaded top cover. These parts are not considered to be under pressure in normal conditions. O-rings must be inspected for wear or damage during disassembly of the cover or housing and right before assembling the unit. If any elastomer is damaged, it must be replaced. FKM elastomers have an unlimited shelf life.
Lubrication	The LME is offered in stainless steel. Use petroleum jelly lubrication when assembling the cover to the LME housing. Other components, except O-rings do not require lubrication.
Inspect stored equipment	Examine the internal surfaces and flange faces of the turbine meter at least once every three months. Repack the turbine meter per original conditions.
Labels and nameplates	Do not remove nameplates or labels. Doing so will void the turbine meter warranty.
Stacking	When stacking equipment, follow all safety standards, taking into account the type of box used, the maximum height of the equipment, the maximum number of boxes stacked, etc.

4 PREPARE THE TURBINE METER FOR USE

4.1 LIFTING CONDITIONS

**⚠ WARNING
CRUSHING HAZARD**

During turbine meter installation or removal, always place the unit on a stable platform or surface that supports its assembled weight.

Failure to comply could allow the turbine meter to roll, resulting in death, serious injury or equipment damage.

**⚠ WARNING
LIFTING HAZARD**

The lifting instructions are for installation and removal of the Daniel Liquid Turbine Meter only and do not address lifting the turbine meter while it is attached or bolted to piping.

Failure to comply with these instructions may result in death, serious injury, or equipment damage.

**⚠ CAUTION
FORKLIFT HAZARD**

Do not insert the forks of a forklift into the bore when moving the turbine meter.

Inserting the forks may cause the meter to become unstable, resulting in serious injury or equipment damage.

TABLE 4-1: LIFTING AND INSTALLATION CONDITIONS

Parameter type	Description
Lighting and ventilation	Install the turbine meter in a well lit and ventilated location, not less than one meter (approximately three feet) from source of ignition or source of heat which might damage the unit.
Work area clearances and installation height restrictions	Refer to Minimum clearances for installation, operation and maintenance.
Surface considerations	Stable surface.
Soil/floor loadings and product/piping support	Follow local procedures that meet the standards for soil/floor loading and product/piping support.

4.2 LIFTING REQUIREMENTS FOR PERSONNEL

**⚠ WARNING
EQUIPMENT HANDLING AND OPERATING HAZARD**

Wear personal protective equipment appropriate to the situation when working with the turbine meter. Adhere to all safety standards and best practices for operating the equipment.

Failure to comply may result in death or serious injury.

Best lifting practices

**⚠ WARNING
LIFTING HAZARD**

The lifting instructions are for installation and removal of the Daniel Liquid Turbine Meter only and do not address lifting the turbine meter while it is attached or bolted to piping.

Failure to comply with these instructions may result in death, serious injury, or equipment damage.

4.2.1 EQUIPMENT REQUIRED TO LIFT THE TURBINE METER

**⚠ WARNING
CRUSHING HAZARD**

During turbine meter installation or removal, always place the unit on a stable platform or surface that supports its assembled weight.

Failure to comply could allow the turbine meter to roll, resulting in death, serious injury or equipment damage.

IMPORTANT

Prior to lifting the unit refer to Minimum clearances for installation, operation and maintenance for the assemble weight.

The following instructions provide general guidelines using lifting slings only on the Daniel turbine meter. Use appropriately rated lifting slings when lifting the turbine meter.

Safety precautions using appropriately rated lifting slings

When lifting a liquid turbine meter by itself, Daniel recommends using lifting slings appropriately positioned at designated areas of the turbine meter.

⚠ WARNING
LIFTING HAZARD

The lifting instructions are for installation and removal of the Daniel Liquid Turbine Meter only and do not address lifting the turbine meter while it is attached or bolted to piping.

Failure to comply with these instructions may result in death, serious injury, or equipment damage.

Read and follow the safety precautions listed below.

- Never attempt to lift the turbine meter by wrapping slings around the electronics enclosure.
- Never attempt to lift the turbine meter using only one sling around the turbine meter. Always use two slings wrapped around each end of the body (refer to Figure 4-1). A choker style sling with a spreader bar is recommended.

FIGURE 4-1: CORRECT SLING ATTACHMENT

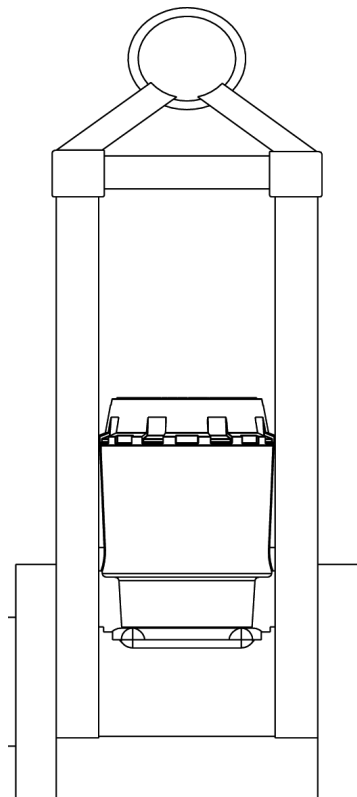

- Prior to use, visually inspect the slings for any signs of abrasion or other damage. Refer to the sling manufacturer for inspection procedure specific to the sling you are using.
- Only use slings with ratings that exceed the weight to be lifted. Reference your company's standards for safety factors that must be included when calculating the load rating.
- If the slings do come in contact with the electronics, use a spreader bar on the sling to prevent contact with the electronics.

IMPORTANT

Never allow the slings to come in contact with the electronics enclosure. Damage to the enclosure may occur.

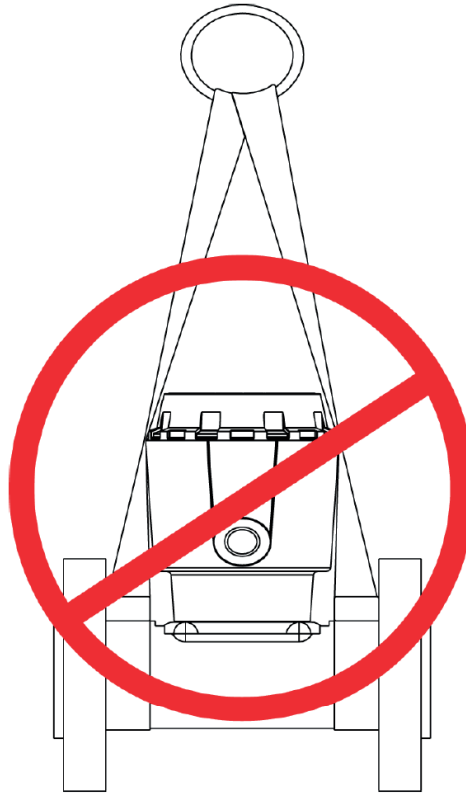
FIGURE 4-1: CORRECT SLING ATTACHMENT

⚠ CAUTION
LIFTING HAZARD

Lifting the turbine meter with the upper enclosure installed but without the bolts installed, may cause the electronics to fall.

Doing this may cause injury and/or damage the equipment.

- Never apply shock loads to the turbine meter. Always lift the turbine meter gradually. If shock loading occurs, inspect the slings per manufacturer's recommendations prior to further use.

4.3 CONFIGURATION OF THE TURBINE METER

The Daniel factory configures the turbine meter internal components. Inspect the internal components before installation.

4.3.1 ORIENTATION AND POSITION OF THE TURBINE METER

Flow direction

Turbine meters can be used for uni-directional flows. The design of the internal features of the meter housing and the internal components depend on the desired configuration. Install the LTM carefully so it complies with the correct inlet and outlet sides (See label on the turbine meter for inlet direction).

Flow conditioning

The flow stream must be free of swirl for a turbine meter to perform consistently and accurately. The internal assembly supports of a turbine meter offer a slight straightening effect. If additional flow conditioning is required, use straightening vanes or tube bundles. Refer to API MPMS, Chapter 5, Section 3.

4.3.2 PIPING RECOMMENDATIONS

FIGURE 4-3: TYPICAL INSTALLATION FOR A SERIES 1200 LTM

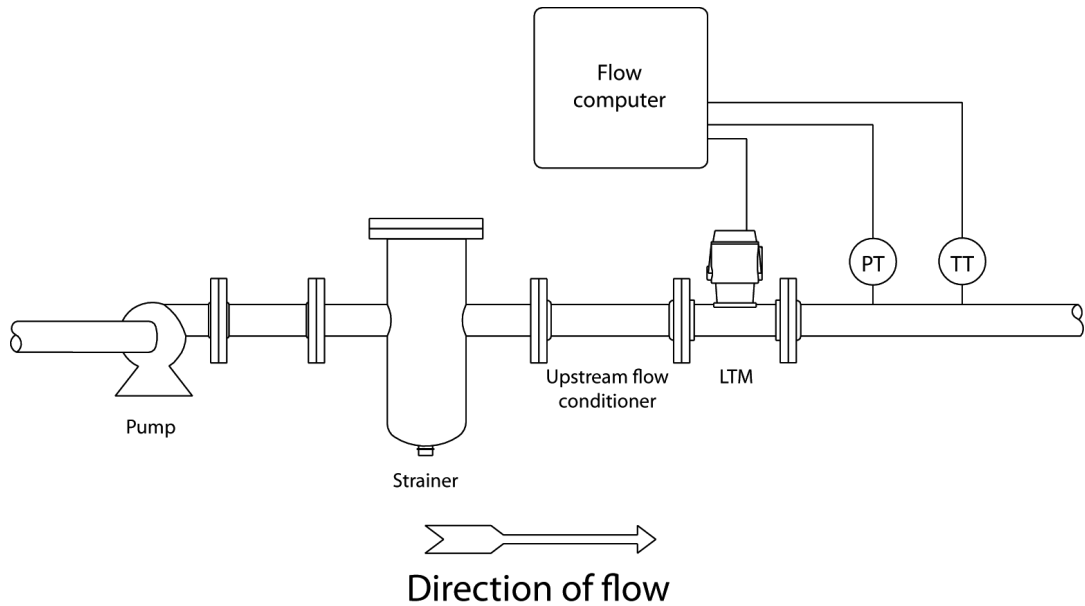

- Note the direction of flow indicated on the plate near the inlet flange and install accordingly.
- New installations: Flush lines thoroughly to rid piping of potentially damaging foreign material such as welding bead, pipe scale, etc. before the turbine meter is placed into service.

IMPORTANT

A spool piece installed in place of the turbine meter is recommended for this procedure.

NOTICE

Comply with local government regulations and company requirements.

IMPORTANT

Ensure that piping or other attachments connected to the turbine meter are not under stress.

IMPORTANT

Provide fire prevention measures and equipment per local regulations.

4.3.3 CALIBRATION OPTIONS FOR THE TURBINE METER

Daniel offers a standard six-point calibration (from 10% to 100%); or can provide other customer requested calibration data.

TABLE 4-2: STANDARD CALIBRATION FOR A DANIEL LIQUID TURBINE METER

Calibration type	Description
Linearity	NPS 1-2 ± 0.25%: Standard NPS 3-4 ± 0.15%: Standard NPS 1.5-2 ± 0.15%: Premium
Repeatability	± 0.02%

4.3.4 CALIBRATION OPTIONS FOR THE TURBINE METER

TABLE 4-3: PREAMPLIFIER POWER REQUIREMENTS	
Power requirement type	Description
Pickoff	<ul style="list-style-type: none"> Type: 2-wire reluctance Resistance: 600-900 Ohms Inductance: 250 mH max Output: Sinusoidal 40mV p-p minimum @ minimum flow with preamplifier load
Dual channel preamplifier	Inputs Supply voltage: 10-30 VDC Sensor type: Reluctance Signal: Sine wave Preamplifier sensitivity: 40 mV peak to peak minimum Temperature range: -40 °C to 85 °C (-40 °F to 185 °F)
	Outputs Powered pulse output: <ul style="list-style-type: none"> Type: Square wave Frequency range: 0 to 5 kHz Amplitude: 0 to 5 V 1000 Ohm internal pull-ups, 20 mA, max. Variable voltage output: <ul style="list-style-type: none"> Type: Square wave Frequency range: 0 to 5 kHz Amplitude: 0 to Supply voltage 1000 Ohm internal pull-ups, 70 mA, max.

4.3.5 GROUNDING

Ground the turbine meter electronics internally for safe operation. Connect a wire to the chassis ground lug located inside the LME as the primary ground. A secondary ground is located outside of the LME. Refer to Figure 4-4 and Figure 4-5. Digital grounds should never be connected to chassis ground.

FIGURE 4-4: EXTERNAL GROUND LUG

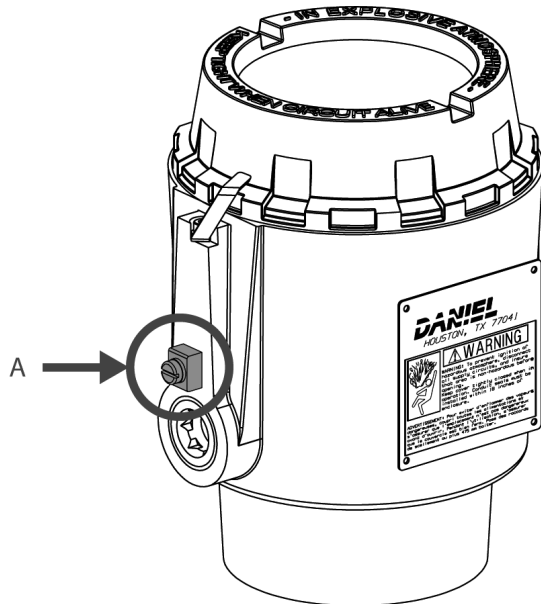

A. External ground lug

FIGURE 4-5: INTERNAL GROUND LUG

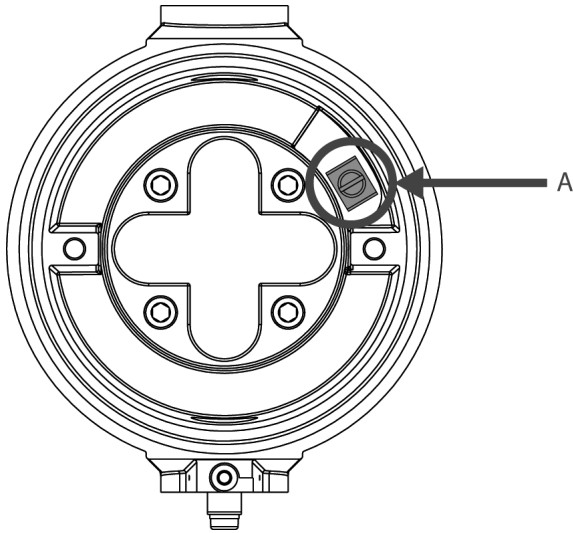

A. Internal ground lug

IMPORTANT
Use the internal grounding terminal as the primary equipment ground. The external terminal is only a supplemental bonding connection where local authorities permit or require such a connection.

4.3.6 LME communication connectivity restrictions

The pickoff input signal connections are made at terminal strip connection TB2 for Channel A, and TB3 for Channel B. Power supply and output signal connections are made at terminal strip TB1. Refer to Table 2-4.

- IMPORTANT**
- For single channel wiring use multi-conductor control and instrumentation cable (18AWG), or equivalent.
 - Earth ground shield at one end only.
 - Insulate the shield at the other end.
 - For dual channel wiring use multi-conductor control and instrumentation cable (18AWG), or equivalent.
 - Connect both shields to earth ground at one end of the cables and insulate the shields at the other end.
 - The LME housing should be at earth ground.

4.3.7 INSTALL THE SECURITY SEAL

Security seals protect the integrity of the turbine meter metrology and prevent tampering with the pre-amplifier and pickoffs. The section below details how to properly seal the Daniel 1200 LTM after commissioning. The security seal wires are commercially available.

**⚠ CAUTION
CUTTING HAZARD**

Sharp edges may be present on the band shrouds. Wear appropriate personal protective equipment when working on the turbine meter.

Failure to comply may cause serious injury.

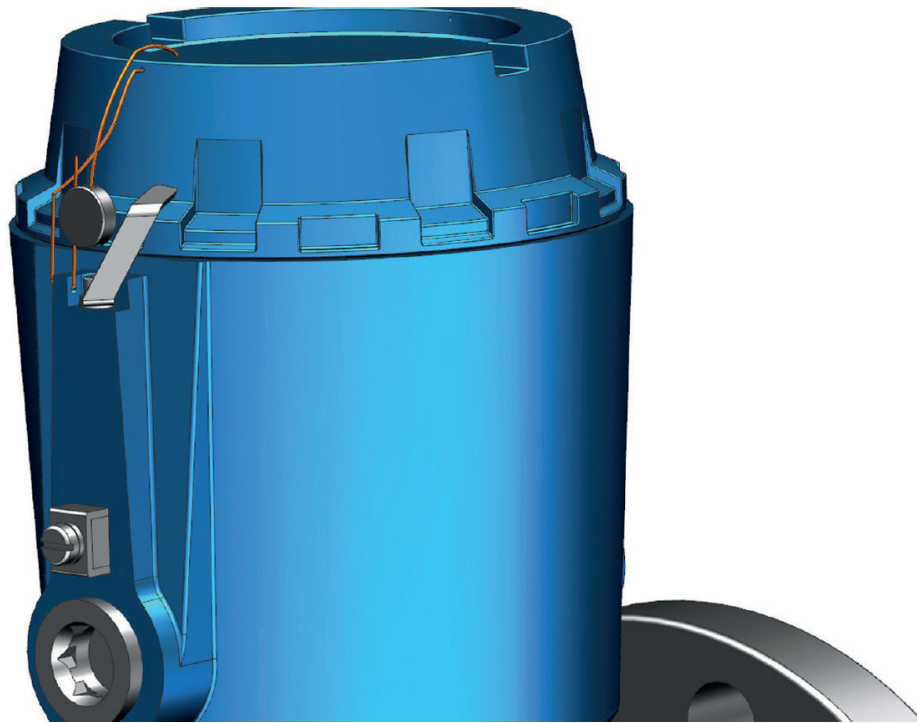
FIGURE 4-6: SECURITY SEAL WIRE

Follow the steps below to seal the electronics enclosure.

Procedure

1. Rotate the end cap clockwise, fully closing and compressing the end cap seal. Install the security latch using a 3mm Allen wrench.
2. Install the security seal wire into and through one of the two holes in the end cap and the housing. Choose holes that minimize counterclockwise rotation of the end cap when the security wire is taut (maximum wire diameter 2.0 mm, .078 inch).
3. Adjust the security wire, removing all slack and thread into the lead seal.
4. Cut the ends of the wire to remove any excess wire.

PART II INSTALL

5 INSTALLATION PREREQUISITES

5.1 PRE-START CHECKS

Procedure

1. Inspect all electrical connections to ensure compliance to electrical codes and safety regulations.
2. Inspect all bolts used to secure the turbine meter in line to ensure that correct mounting procedures have been followed and that flange connections are leakfree.
3. Evaluate the system setup to ensure that all components are in the correct sequence for accurate product measurement: isolation valve, strainer, flow straightener, turbine meter, downstream section, control valve, etc.
4. Ensure that the supply voltage to the preamplifier is within the 10-30 VDC range.

5.2 TORQUE INFORMATION

NOTICE

When installing this equipment, bolting must conform to the requirements of ASME B16.5 paragraph 5.3 and to the material requirements of ASME B16.5 Table 1B. Gaskets must conform to the requirements of ASME B16.20. This is applicable for class 150 to 300.

IMPORTANT

When installing flange, follow the customer’s best internal practice procedures.

5.3 TOOLS REQUIRED FOR LME DISASSEMBLY/ASSEMBLY

Use the following tools for disassembly/assembly of the turbine meter electronics (LME):

- 6 mm Allen key
- 3 mm Allen key
- 2.5 mm Allen key
- 3/32 Allen key
- 10 mm Allen key
- Phillips screwdriver
- 3.5 mm Flathead screwdriver
- 10 mm Flathead screwdriver

6 INSTALLATION PREREQUISITES

6.1 CATHODIC PROTECTION

TABLE 6-1: STANDARDS FOR CATHODIC PROTECTION

Material	Daniel standard cathodic protection ⁽¹⁾
Carbon steel	Zinc Phosphate

(1) Consult the factory for other protection.

6.2 MECHANICAL COMPONENTS ASSEMBLY

Install the meter housing (e.g., flanges) onto the pipeline.

The meter housing internal components are assembled by the factory. The components do not need to be uninstalled or reinstalled unless maintenance is required.

6.2.1 FASTENERS

Property class of the fastener is in accordance with ASME B16.5.

Stud bolt and nut types

All fasteners (nuts and studs) used in assembling Daniel turbine meters are made of one of the materials listed in the table below.

TABLE 6-2: BOLT MATERIAL SELECTION

Bolt material selection	Description
ASTM SA 193 Grade B7 <63.5 mm (<2.5 in.)	High strength low alloy steel
ASTM SA 193 Grade B7M <63.5 mm (<2.5 in.)	Controlled strength low alloy steel
ASTM SA 320 Grade L7 <63.5 mm (<2.5 in.)	High strength low alloy low temperature steel

TABLE 6-2: BOLT MATERIAL SELECTION (CONTINUED)

Bolt material selection	Description
ASTM SA 320 Grade L7M <63.5 mm (<2.5 in.)	Controlled hardness low temperature steel
ASTM SA 449 <25.4 mm (<1.0 in.)	Quenched and tempered steel
ASTM SA 453 Grade 660	High temperature stainless steel

Selection of flange stud bolts and nuts

- Select all fasteners (nuts and studs) used in a hydrostatic test according to the flange size and quantity listed in ASME ANSI B16.5.
- Use the shortest stud bolt that permits full engagement of the thread through the nut by hand-tightening.
- Use only clean, rust-free nuts and stud bolts.

IMPORTANT

Ensure that once the nut is tightened, two threads outside the nut are exposed. The only exception is when a flange requires hydraulic bolt tensioning. The manufacturer of the hydraulic bolt tensioning equipment will specify number of exposed threads outside the nut.

- Do not use damaged or worn stud bolts or nuts.
- Do not use nuts or stud bolts that do not fit correctly together.
- Do not use nuts or stud bolts without grade or type identification.
- Do not mix nuts or stud bolts of different coatings. Different nut and stud bolt coatings require different torques to achieve the same bolt tension.
- Do not assemble nuts with the identification hard stamp against the back face of the flange.

Flange stud bolt and nut storage

Remove each nut and bolt as a pair. Thread the matching nut back onto the bolt. Stack them in a fashion that will not cause thread damage.

Reuse of flange stud bolts and nuts

Daniel Quality Control permits the reuse of threaded fasteners under the following conditions:

- Fasteners are clean, free of corrosion, paint, thread damage, cracks, teeth marks (caused by wrenches) or other signs of damage.
- Fasteners are not tightened to or beyond their yield strength.
- Fasteners have not lost their coating.

Compare the threads of a used stud bolt with the thread of a new stud bolt. Finger-tighten the nut over the entire length of the bolt.

6.3 ASSEMBLE THE ELECTRONIC COMPONENTS

Follow the procedure below to install the LME electronics

Prerequisites

**⚠ WARNING
VOLTAGE HAZARD**

Disconnect equipment from power before opening the LME and/or RME. Do not open them while power is on and an explosive gas atmosphere is present.

Failure to comply may result in death or serious injury.

Procedure

1. Remove the security seal wire.
2. Remove the security latch using the 3 mm Allen key.

IMPORTANT

The security latch prevents the removal of the LME cover in a flameproof environment.

3. Unscrew the end cap and remove it from the housing.
4. Unplug one or two 3/4-14 NPT ports (as required) and install the conduit (provided by the customer) to the enclosure and tighten.
5. Install the electronics according to Wiring and cable connections. Consult Daniel if a preamplifier other than a dual-channel model is acquired.

**⚠ WARNING
SHOCK AND EXPLOSION HAZARD**

Verify that the LME and/or RME is grounded.

Failure to comply may cause death, serious injury and/or equipment damage.

6. Screw the end cap to the housing. Hand-tighten, only if required.
7. Install the security latch.

7 TESTING

7.1 TEST THE TURBINE METER

7.1.1 COMMISSION THE TURBINE METER

After installation, commission the turbine meter to ensure that the equipment is working properly.

Procedure

1. Inspect all electrical connections to ensure compliance with electrical codes and safety regulations.
2. Inspect all flange bolts used to secure the turbine meter in-line to ensure that correct mounting procedures are followed and that flange connections are leakfree.
3. Evaluate the system setup to ensure that all components are in the correct sequence for accurate product measurement: isolation valve, strainer, flow straightener, turbine meter, downstream section, control valve, etc.
4. Ensure that the supply voltage to the preamplifier is within the 10-30 VDC range.

PART III OPERATE

8 OPERATION PARAMETERS

8.1 OPERATION OVERVIEW

The Daniel Series 1200 LTM is a volumetric flow measuring and transmitting device that produces an output signal proportional to the rate-of-flow of the liquid being measured. The primary output is a single or dual high resolution signal that is amplified and shaped by an integral preamplifier mounted within an explosion proof housing. This square wave pulse can be fed directly to remote totalizer, digital readout devices or control instrumentation.

⚠ WARNING
EXCEEDING PARAMETER HAZARD

Turbine meter parameters are set for safe equipment use. Do not exceed these parameters.

Failure to comply may result in death, serious injury and/or damage to the equipment.

8.2 TURBINE METER NORMAL OPERATION

After any reparation or installation of a new turbine meter, calibrate it to confirm the meter factor or establish a new meter factor for the turbine meter as it is installed at the site.

The customer has various options to calibrate their turbine meter. Either by their on site stationary small volume bidirectional - unidirectional or master meter. This calibration service is also available from Daniel.

During operation, the customer data center will download to the terminal automated system (TAS) the orders to be schedule to the pipeline to various customers. TAS and turbine meter electronic pre-set monitor, control and collect batch volumes on each order and return all information as if it occurs to the TAS or invoicing.

8.3 BACK PRESSURE CALCULATION FOR THE LTM

Flow and pressure information is stamped on the nameplate located on the outside of the meter.

- Back pressure at the outlet of the turbine meter must be sufficient for accurate operation.
- Consider the following equation when determining back pressure for the turbine meter.

$$P_b \geq 2 \Delta p + 1.25p_e$$

P_b Minimum back pressure, pounds per square inch gauge (psig)

Δp Pressure drop through the meter at the maximum operating flow rate for the liquid being measured, pounds per square inch (psi).

P_e Equilibrium vapor pressure of the liquid at the operating temperature, pounds per square inch absolute (psia), gauge pressure plus atmospheric pressure.

- Open valves slowly to prevent system shock.
- Protect the Series 1200 housing and components from external impact of any kind. Note temperature limitations when selecting turbine meter location.

IMPORTANT

Always use a flushing medium that is compatible with the metallurgy of the meter, internal components. Using water as a flushing medium may result in damage to the internal components of the turbine meter.

PART IV MAINTAIN

9 OPERATION PARAMETERS

9.1 MAINTENANCE CONSIDERATIONS

Read and understand all instructions and operating procedures before performing maintenance procedure, internal component inspections or field requirement changes.

To ensure safe and accurate performance, only informed and trained personnel should install, operate, repair and maintain this product.

IMPORTANT

Follow the disassembly and the assembly procedure for internal component inspection or field requirement changes.

Follow the recommendations below before servicing the turbine meter:

- Label all parts or place parts in labeled containers during disassembly.
- Do not use metal clamping devices in direct contact with any turbine meter part or surface.
- Rotor blades determine accurate flow measurement and should be handled with extreme care. Bending or altering the blades in any way can affect turbine meter accuracy.

9.2 TOOLS REQUIRED FOR MECHANICAL COMPONENTS

The turbine meter requires a set of tools for assembly or disassembly.

Flange installation tools

Follow all best practice procedures when installing or removing flanges.

Internal component tools

Use the following tools for turbine meter disassembly:

- Needle nose pliers.
- Torque wrench (dependant on size).
- Ratchet with correspondent hex socket (dependant on size), or screwdriver with hexagonal tip.
- 3 mm Allen key.
- 3.5 mm flathead screwdriver.
- Mallet.

9.3 PREPARE FOR MECHANICAL DISASSEMBLY

Protect the rotor blades from rough handling. Blade position is critical to turbine meter performance. Before removing the turbine meter from the system, consider the following precautions.

Prerequisites

WARNING **EQUIPMENT HANDLING AND OPERATING HAZARD**

Wear personal protective equipment appropriate to the situation when working with the turbine meter. Adhere to all safety standards and best practices for operating the equipment.

Failure to comply may result in death or serious injury.

WARNING **PRESSURE HAZARD**

The turbine meter is subject to pressurized fluids. Depressurize the turbine meter before disassembly.

Failure to comply may cause high pressure fluids to leak, resulting in death or serious injury.

WARNING **VOLTAGE HAZARD**

Disconnect equipment from power before opening the LME and/or RME. Do not open them while power is on and an explosive gas atmosphere is present.

Failure to comply may result in death or serious injury.

Procedure

1. Disconnect all power to the turbine meter and vent all line pressure.
2. Remove security wire.
3. Remove screws and top cover of the LME.

4. Disconnect wire connections from the LME.
5. Disconnect the grounding cables.
6. Disconnect conduit connections to the turbine meter.
7. Remove turbine meter from line. Refer to Lifting equipment Lifting conditions, Lifting requirements for personnel, and Safety precautions using appropriately rated lifting slings for instructions on lifting the turbine meter.

9.3.1 DISASSEMBLE INTERNAL METER HOUSING COMPONENTS - NPS 1

Procedure

1. Remove the C-clip at the inlet flange using pliers.

FIGURE 9-1: C-CLIP REMOVAL

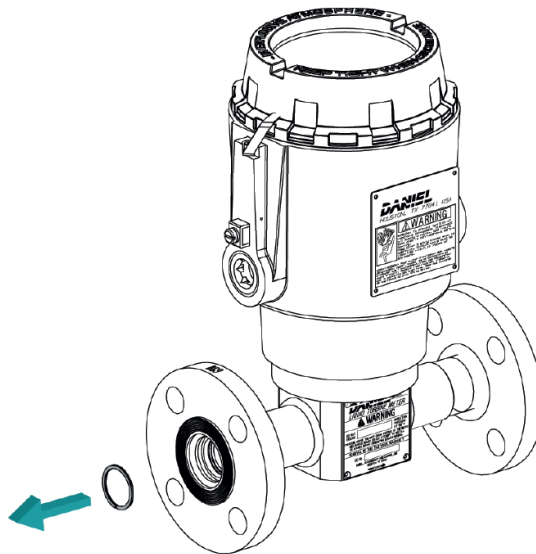

2. Remove the sleeve. You may need to GENTLY tap the internals from the downstream end using a soft punch to start the process.

FIGURE 9-1: C-CLIP REMOVAL

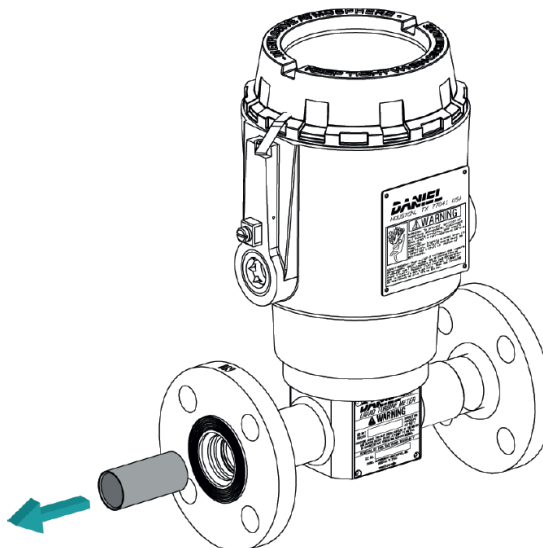

- Carefully remove the upstream sleeve. This is one piece.

IMPORTANT

The shaft and rotor assembly may come out with this. The bearings, shaft and rotor will fall out of the meter body if tipped. Handle the rotor with care. Improper handling of the rotor assembly may cause distortion to the rotor blades thereby affecting meter performance.

FIGURE 9-3: UPSTREAM STATOR REMOVAL

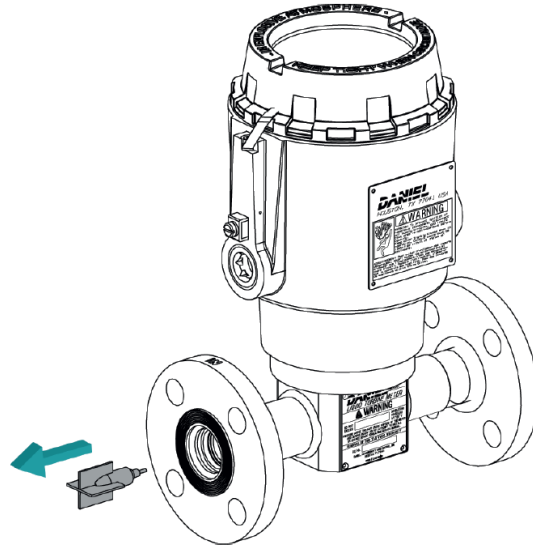

- Remove the complete internals of the meter.

FIGURE 9-4: INTERNALS OF THE METER

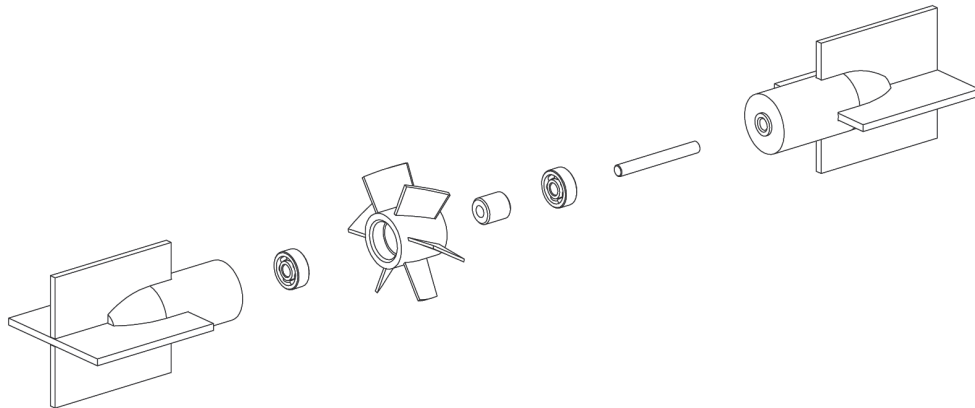

9.3.2 DISASSEMBLE INTERNAL METER HOUSING COMPONENTS - NPS 1.5 THROUGH 2

Procedure

- Remove the nut, washer and flow conditioning plate by pulling the parts from the center bolt.

FIGURE 9-5: NUT, WASHER AND FLOW CONDITIONING PLATE REMOVAL

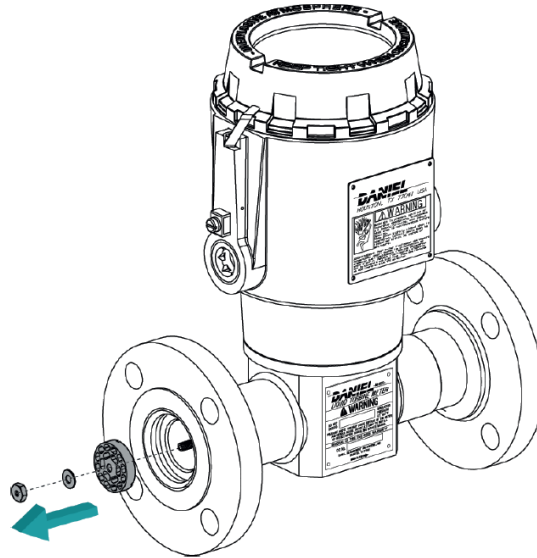

2. Lightly tap the center bolt on the end with a soft-faced mallet to loosen the compression on the support fins. Align the shaft flush with the support fins and lift the fins slightly to remove them from the groove inside the flow tube.
3. Gently remove the internals from the flow tube.

FIGURE 9-6: INTERNALS REMOVAL

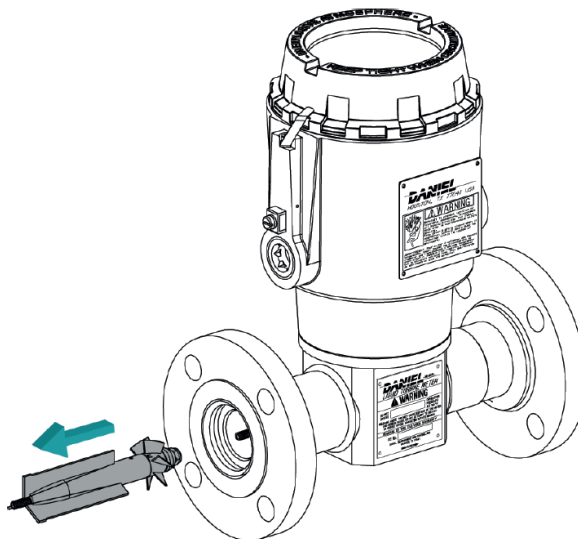

- Remove the nut from the downstream (rotor) end of the internal bullet after laying the support fins aside.

FIGURE 9-7: SUPPORT FINS REMOVAL

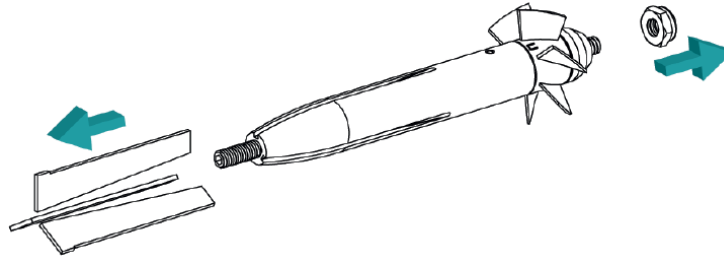

- Remove the downstream stator and rotor from the bolt.

The rotor assembly includes the rotor, two stainless steel ball bearing assemblies and a spacer between the ball races. The ball races are a loose fit in recesses on the rotor hub and may fall out. Be careful not to lose any small parts.

FIGURE 9-8: DOWNSTREAM STATOR AND ROTOR REMOVAL

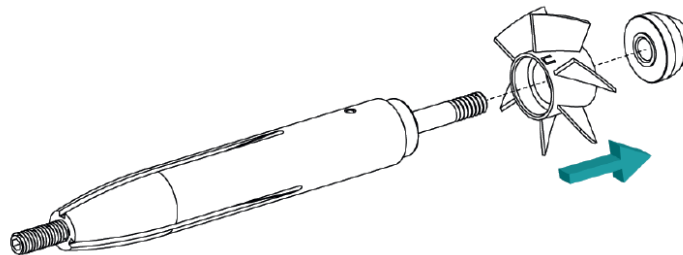

- Disassemble all the internals.

FIGURE 9-9: INTERNALS DISASSEMBLY

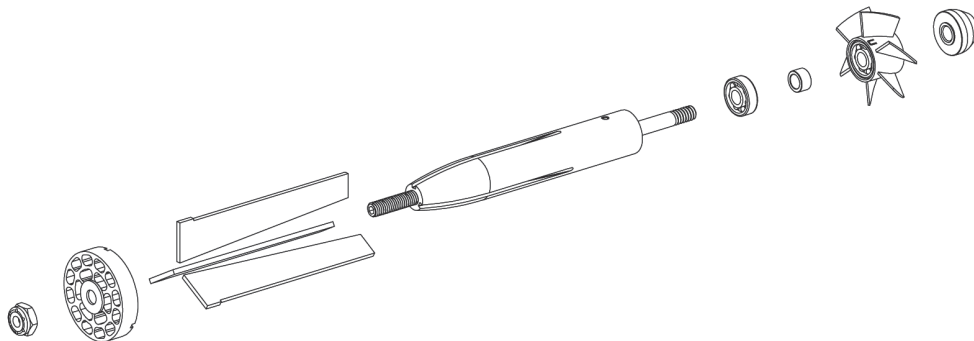

9.3.3 DISASSEMBLE INTERNAL METER HOUSING COMPONENTS - NPS 3 THROUGH 4

The internal components of the Series 1200 Turbine Meter are held in place by selfcentering support fins, pressed against the flow conditioning plate.

Procedure

- Remove the nut, washer, and flow conditioning plate from the center bolt.

FIGURE 9-10: NUT, WASHER, AND FLOW CONDITIONING PLATE REMOVAL

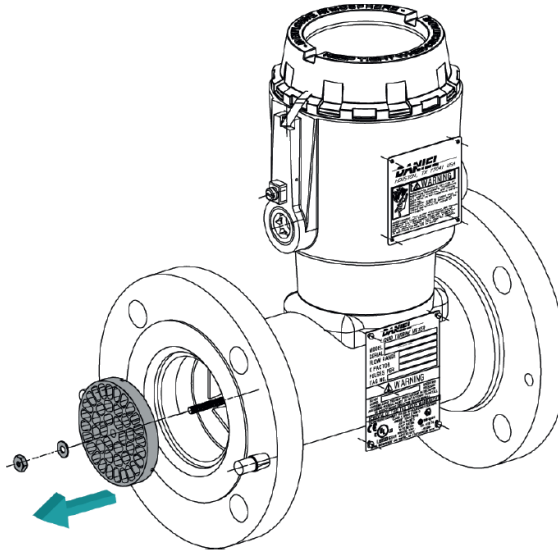

2. Lightly tap the center bolt on the end with a soft-faced hammer (mallet) to loosen the compression on the support fins.
 Push the shaft flush with the support fins and lift the fins slightly to remove them from the groove inside the flow tube.
3. Gently remove the internals from the flow tube.

FIGURE 9-11: INTERNALS REMOVAL

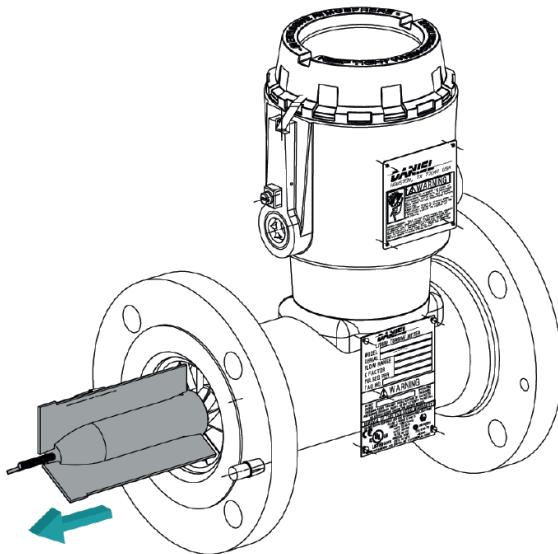

Stainless steel bearing internals disassembly

Procedure

1. Remove the support fins and the internals from the flow tube. Remove the retaining ring from the end of the bearing which supports the rotor.

FIGURE 9-12: RETAINING RING REMOVAL

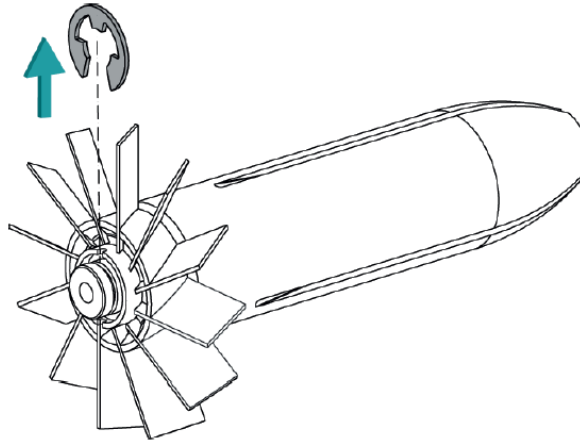

2. Gently slide the rotor from the bearing shaft.

There is an etched "U" on the upstream side of the rotor.

IMPORTANT

Handle the rotor with care. Improper handling of the rotor assembly may cause distortion to the rotor blades thereby affecting meter performance.

FIGURE 9-13: ROTOR REMOVAL

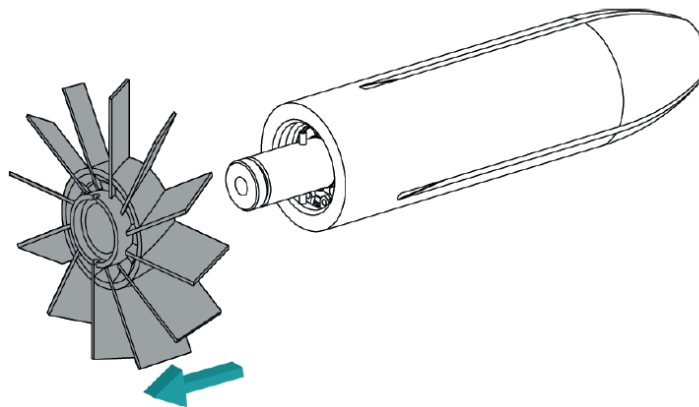

- Remove the internal retaining ring holding the bearing assembly in the diffuser.

FIGURE 9-14: INTERNAL RETAINING RING REMOVAL

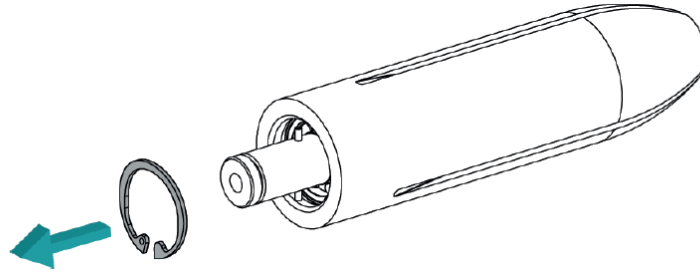

- Remove the bearing assembly from the diffuser. Disassembly is complete.

FIGURE 9-15: BEARING ASSEMBLY REMOVAL

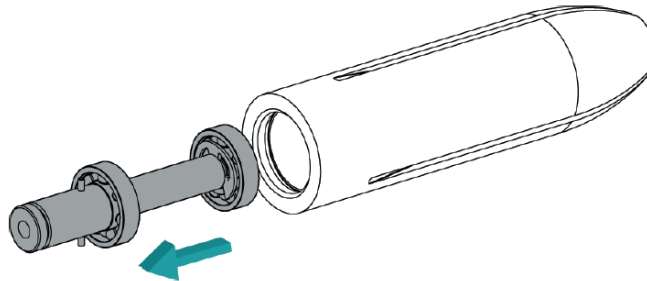

- Remove the bearing assembly retaining rings to inspect and/or replace the individual ball bearing units if necessary.

FIGURE 9-16: BEARING ASSEMBLY RETAINING RINGS REMOVAL

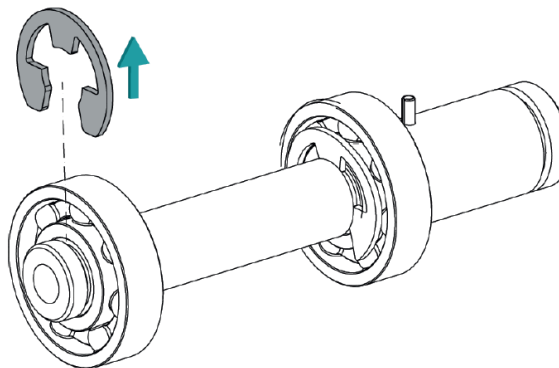

Tungsten carbide bearing internals disassembly

Procedure

- Lay the support fins aside and remove the cotter pin from the castle nut after removing the internals from the flow tube.

FIGURE 9-17: COTTER PIN REMOVAL

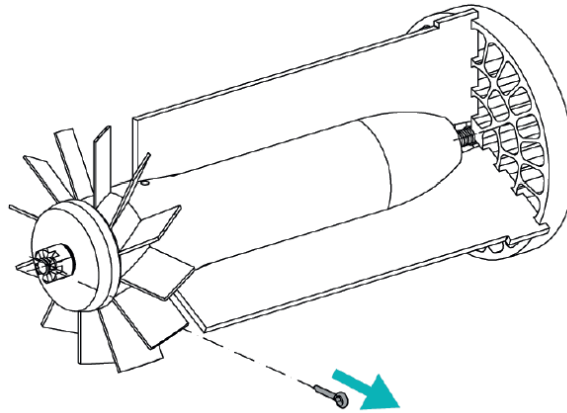

2. Remove the castle nut from the shaft.

FIGURE 9-18: CASTLE NUT REMOVAL

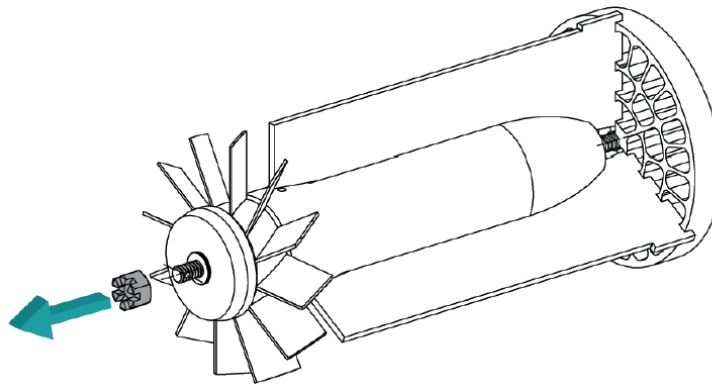

3. Remove the outlet diffuser cap and Belleville washers.

FIGURE 9-19: DIFFUSER CAP AND BELLEVILLE WASHERS REMOVAL

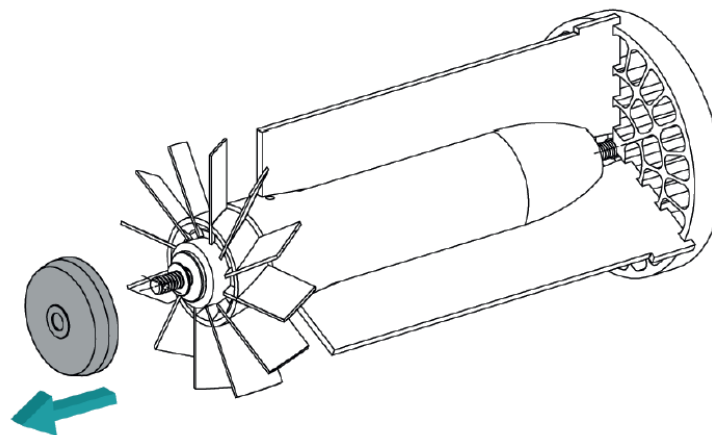

- Remove the downstream thrust washer from the shaft. Note that the slot faces the rotor.

FIGURE 9-20: DOWNSTREAM THRUST WASHER



- Gently slide the rotor from the bearing shaft. Note the orientation of the rotor.

IMPORTANT

Handle the rotor with care. Improper handling of the rotor assembly may cause distortion to the rotor blades thereby affecting meter performance.

FIGURE 9-21: ROTOR REMOVAL



- Remove the shaft sleeve from the bearing shaft.

FIGURE 9-22: SHAFT SLEEVE REMOVAL



- Remove the upstream thrust washer. Note that the slot faces the rotor. Disassembly is complete.

FIGURE 9-23: UPSTREAM THRUST WASHER REMOVAL



9.4 MECHANICAL ASSEMBLY

Protection for rotor blades from rough handling as blade position is critical to turbinemeter performance.

Use appropriate torque values to reinstall the shaft nut and to avoid equipment damage or inaccurate turbine meter operation.

IMPORTANT

The shaft nut can only be reused up to five times. Replace as needed.

9.4.1 ASSEMBLE INTERNAL METER HOUSING COMPONENTS - NPS 1

Procedure

- Insert the internals as a single assembly.

IMPORTANT

The shaft and rotor assembly may come out as an assembly. The bearings, shaft and rotor will fall out of the meter body if tipped. Handle the rotor with care. Improper handling of the rotor assembly may cause distortion to the rotor blades thereby affecting meter performance.

FIGURE 9-24: INTERNALS ASSEMBLY

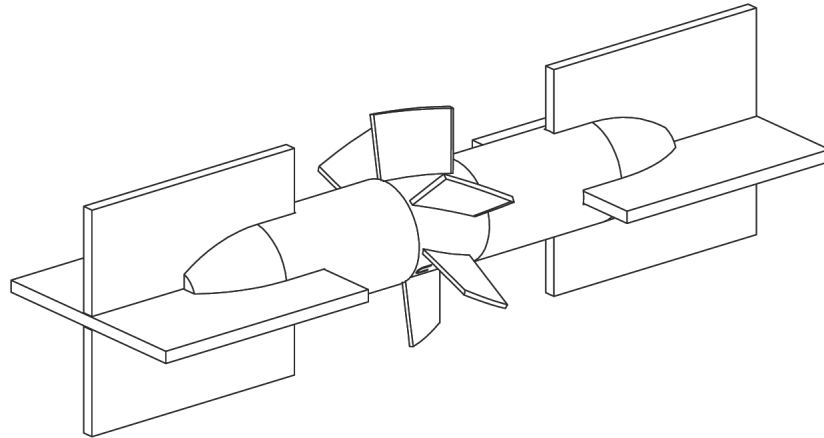

- 2. Install the sleeve.

FIGURE 9-25: SLEEVE INSTALLATION

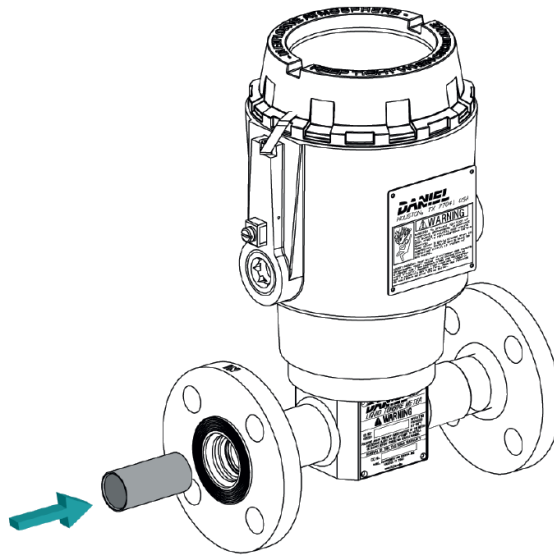

3. Install the C-clip at the inlet flange using pliers.

FIGURE 9-26: C-CLIP INSTALLATION

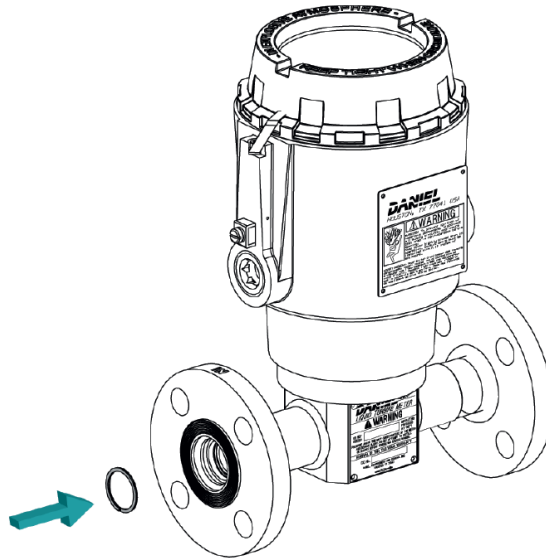

9.4.2 ASSEMBLE INTERNAL METER HOUSING COMPONENTS - NPS 1.5 THROUGH 2

Procedure

1. Fully assemble the internals. The rotor assembly includes the rotor, two stainless steel ball bearing assemblies and a spacer between the ball races. The ball races are a loose fit in recesses on the rotor hub and may fall out. Be careful not to lose any small parts. Install the downstream stator and rotor into the bolt.

IMPORTANT

Handle the rotor with care. Improper handling of the rotor assembly may cause distortion to the rotor blades, affecting meter performance.

FIGURE 9-27: INTERNALS ASSEMBLY

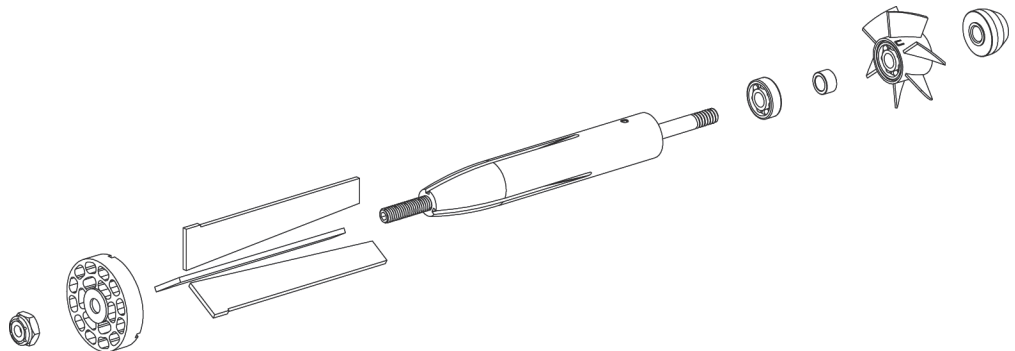

2. Install the support fins and nut from the downstream (rotor) end into the internal bullet.

FIGURE 9-28: SUPPORT FINS AND NUT INSTALLATION

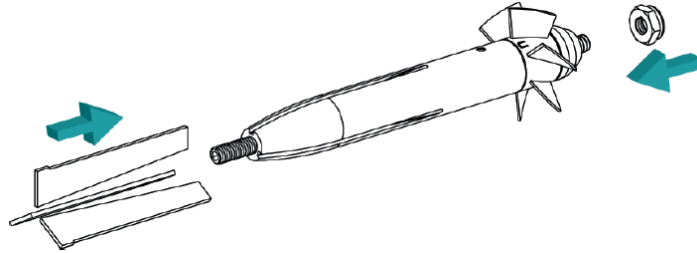

3. Gently install the internals into the flow tube.

FIGURE 9-29: INTERNALS INSTALLATION

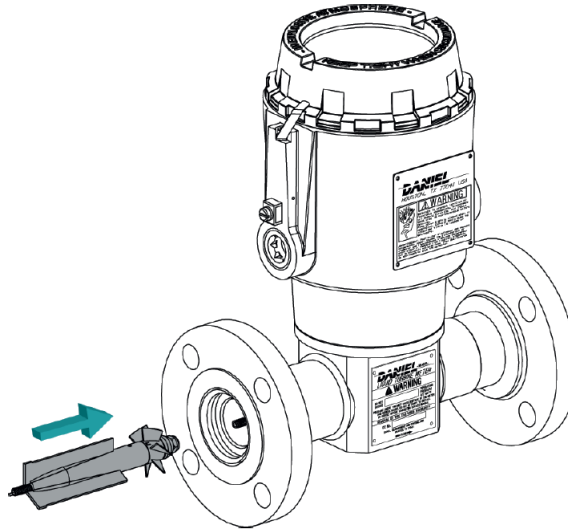

4. Lightly tap the center bolt from the downstream rotor end with a soft-faced mallet to tighten the compression on the support fins.
5. Install the nut, washer and flow conditioning plate.

FIGURE 9-30: NUT, WASHER AND FLOW CONDITIONING PLATE INSTALLATION

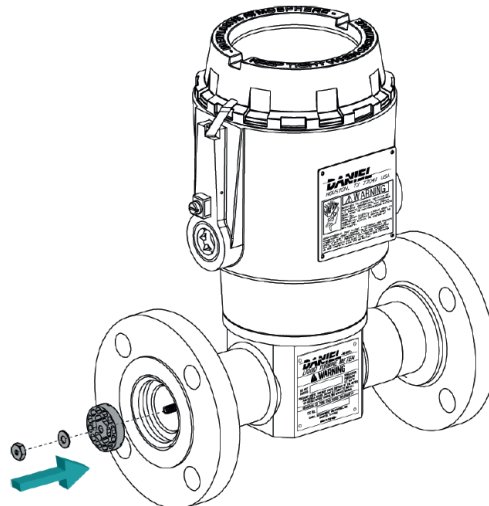

9.4.3 ASSEMBLE INTERNAL METER HOUSING COMPONENTS - NPS 3 THROUGH 4 Stainless steel bearing internals assembly

Procedure

1. Remove the bearing assembly retaining rings to inspect and/or replace the individual ball bearing units if necessary.

FIGURE 9-31: BEARING ASSEMBLY RETAINING RINGS REMOVAL

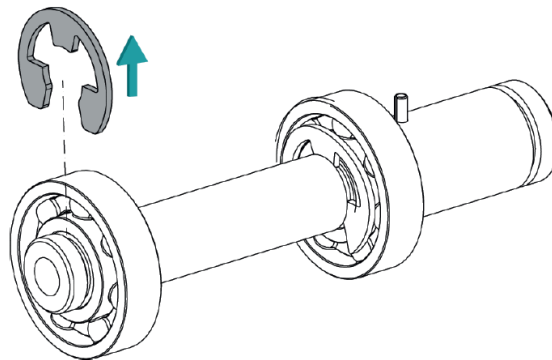

2. Install the bearing assembly into the diffuser.

FIGURE 9-32: BEARING ASSEMBLY INSTALLATION

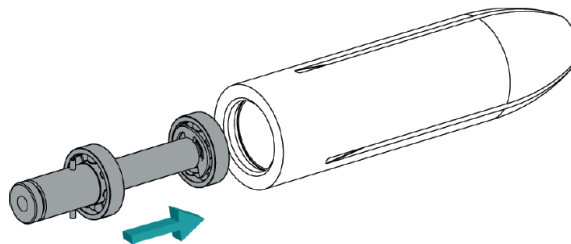

3. Install the internal retaining ring holding the bearing assembly into the diffuser.

FIGURE 9-33: INTERNAL RETAINING RING INSTALLATION

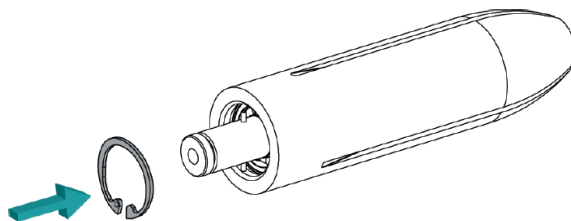

4. Gently slide the rotor into the bearing shaft. There is an etched "U" on the upstream side of the rotor.

IMPORTANT

Handle the rotor with care. Improper handling of the rotor assembly may cause distortion to the rotor blades, affecting meter performance.

FIGURE 9-34: ROTOR INSTALLATION

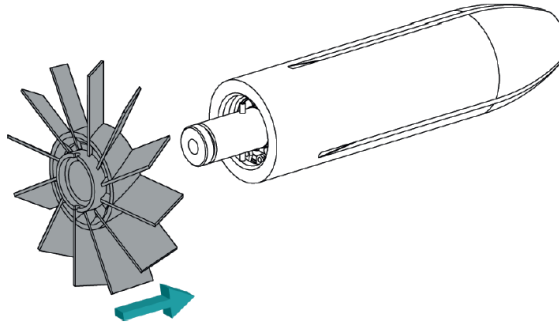

5. Install the retaining ring and support fins to the end of the bearing supporting the rotor.

FIGURE 9-35: RETAINING RING INSTALLATION

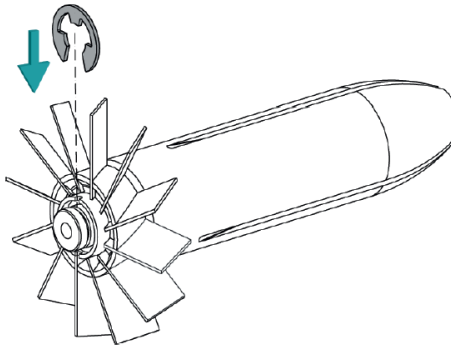

6. Gently install the internals into the flow tube.

FIGURE 9-36: INTERNALS INSTALLATION

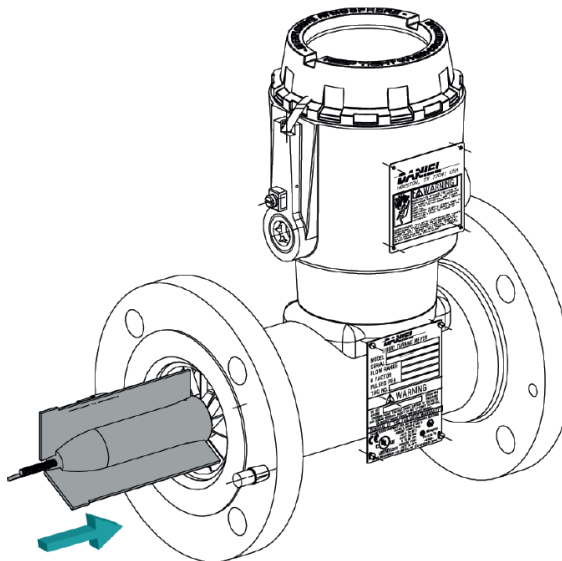

7. Lightly tap the center bolt from the downstream rotor end with a soft-faced mallet to tighten the compression on the support fins.
8. Install the nut, washer and flow conditioning plate if necessary.

FIGURE 9-37: NUT, WASHER AND FLOW CONDITIONING PLATE INSTALLATION

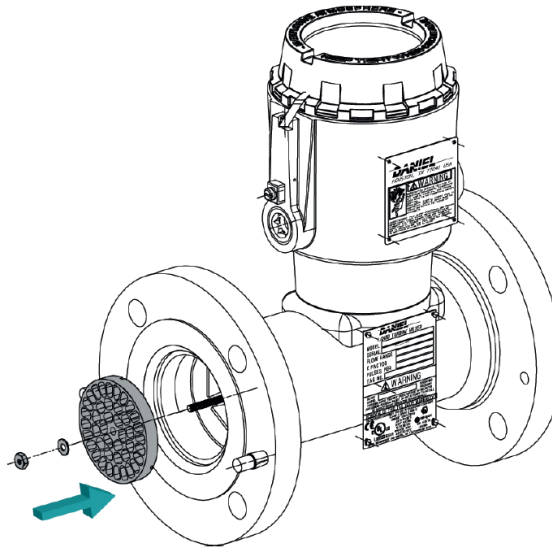

Tungsten carbide bearing internals assembly

Procedure

1. Install the upstream thrust washer. Note that the slot faces the rotor.

FIGURE 9-38: UPSTREAM THRUST WASHER INSTALLATION

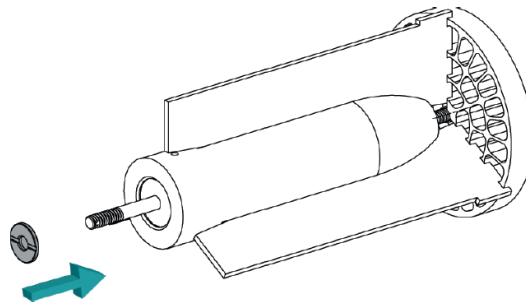

2. Install the shaft sleeve from the bearing shaft.

FIGURE 9-39: SHAFT SLEEVE INSTALLATION

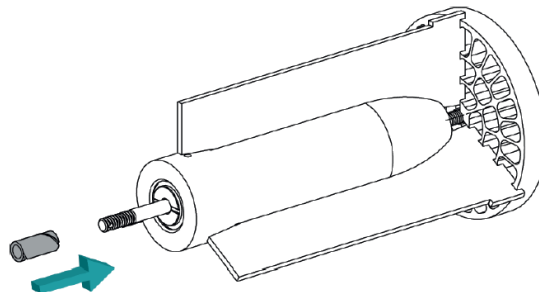

3. Gently slide the rotor into the bearing shaft. Note the orientation of the rotor.

IMPORTANT

Handle the rotor with care. Improper handling of the rotor assembly may cause distortion to the rotor blades thereby affecting meter performance.

FIGURE 9-40: ROTOR INSTALLATION

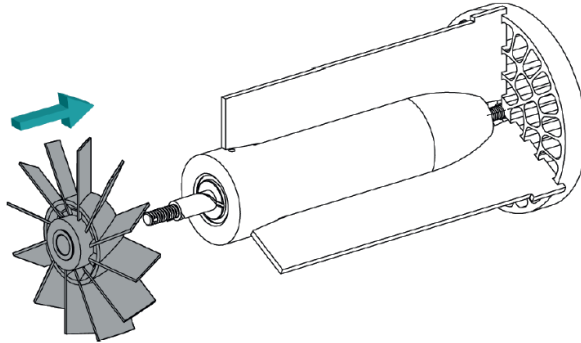

4. Install the downstream thrust washer from the shaft. Note that the slot faces the rotor.

FIGURE 9-41: DOWNSTREAM THRUST WASHER INSTALLATION

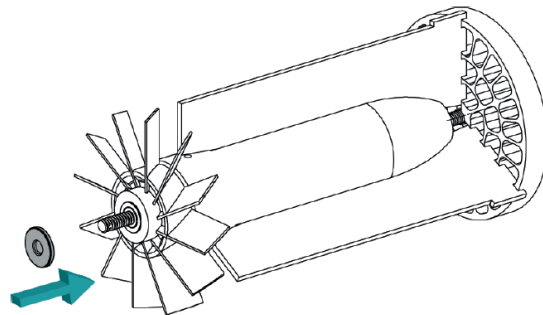

5. Install the outlet diffuser cap and Belleville washers.

FIGURE 9-42: DIFFUSER CAP AND BELLEVILLE WASHERS INSTALLATION

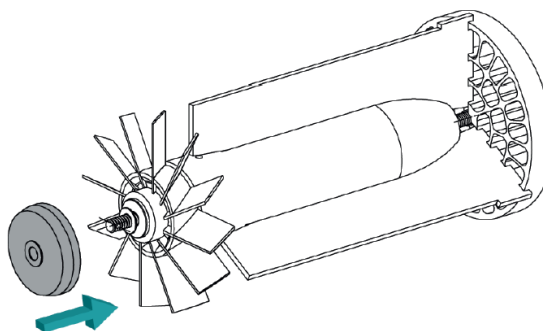

6. Install and tighten the castle nut into shaft.

FIGURE 9-43: CASTLE NUT INSTALLATION

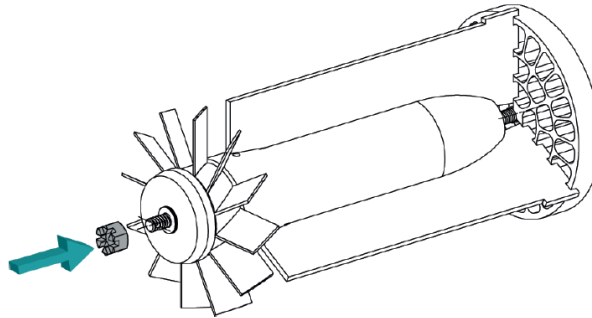

7. Install the support fins and cotter pin into the castle nut.

NOTE

Do not turn the nut counterclockwise to align the cotter pin hole. The nut must be tight on the shaft.

FIGURE 9-44: COTTER PIN AND SUPPORT FINS INSTALLATION

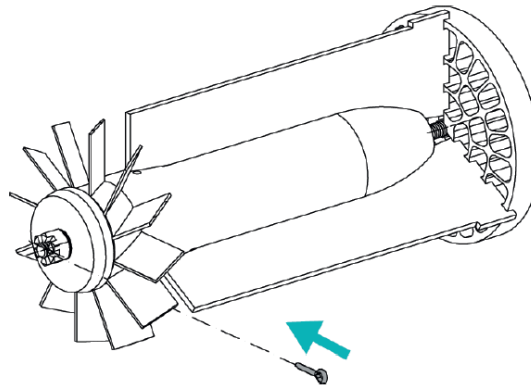

8. Gently install the internals into the flow tube.

FIGURE 9-45: INTERNALS INSTALLATION

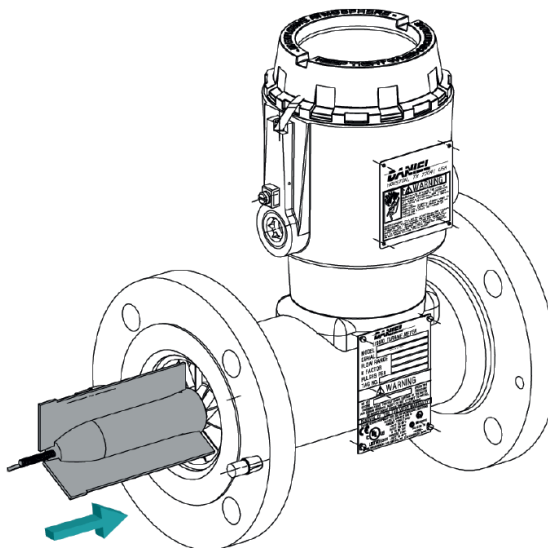

9. Lightly tap the center bolt from the downstream rotor end with a soft-faced mallet to tighten the compression on the support fins.
10. Install the nut, washer and flow conditioning plate if necessary.

FIGURE 9-46: NUT, WASHER AND FLOW CONDITIONING PLATE INSTALLATION

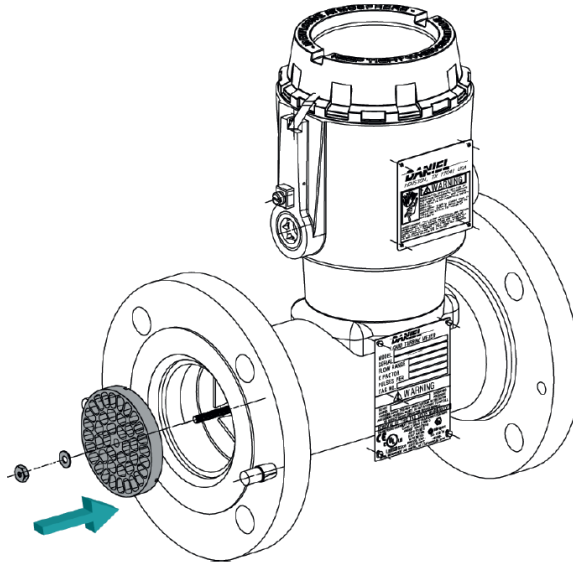

9.5 ELECTRONICS ENCLOSURE DISASSEMBLY

⚠ WARNING **ELECTRONIC HAZARD**

Power off the electronics after every use.

Servicing the turbine meter while powered may result in death or serious injury.

IMPORTANT

Do not use a hammer to assemble the housing.

9.5.1 DISASSEMBLE THE LME - STANDARD ENCLOSURE

Procedure

1. Uninstall the security seal wire.
2. Uninstall the security wire.
3. Uninstall the security latch.
4. Uninstall the solid end cap.
5. Uninstall the wiring connections from the preamplifier.
6. Loosen and remove the socket screws from the plate bracket to the housing.
7. Loosen and remove the preamplifier socket screw to the bracket plate.
8. Loosen the grounding lugs and remove the cable.
9. Uninstall the conduit.
10. Remove the anti-rotation bracket and pickoffs.
11. Uninstall the four socket head screws placed at the bottom of the housing.
12. Remove the housing from the flameproof pad.
13. Uninstall the O-ring from the pad.

9.6 ELECTRONICS ENCLOSURE ASSEMBLY

⚠ WARNING **ELECTRONIC HAZARD**

Power off the electronics after every use.

Servicing the turbine meter while powered may result in death or serious injury.

IMPORTANT

Do not use a hammer to assemble the housing.

NOTICE

The joint between the LME cover and housing is a threaded joint. The joint between the LME housing and Sensor housing is a spigot joint with a minimum axial length of 26.16 mm (1.030 in), radial length of 3.18 mm (0.125 in), and a clearance of 0.07 mm (0.0028 in).

9.6.1 ASSEMBLE THE LME - STANDARD ENCLOSURE

Procedure

1. Install the O-ring on the pad.
2. Install the housing on the turbine meter body or remote mounting pad. Use four screws with a torque value of 74.5 Nm (55 lbs-ft) (Capacity to be installed: each at 90°).
3. Insert pickoffs and anti-rotation bracket.
4. Install the conduit.
5. Install the internal and external grounding cable to lug.
6. Tighten the preamplifier socket screw to the bracket plate.
7. Follow the applicable diagram for the wiring configuration. The preamplifier connectors can be removed by pulling each connector. Refer to Interface parameters for the preamplifier designator. Ensure the torque is less than 4 lbs-in.
8. Tighten the socket screws from the plate bracket to the housing.
9. Install the solid end cap.
10. Install the security seals.
11. Install the security seal wire.

9.7 REPLACE THE PREAMPLIFIER

Procedure

1. Disconnect all power to the turbine meter.
2. Remove cover of the RME.
3. Loosen screws of preamplifier bracket and lift out of the enclosure.
4. Disconnect terminal connects at TB1, TB2, and TB3.
5. Loosen screws of preamplifier and lift out.
6. Mount the replacement preamplifier board in its original position and secure using screws.
7. Attach electrical output wiring from both pickoffs to terminal connection TB2 and TB3.
8. Attach electrical output wiring from electrical accessories (conduit wiring) to terminal connection TB1, number 3 for channel A, and number 5 for channel B.
9. Secure all electrical wiring.
10. Secure screws of preamplifier bracket in to the enclosure.

11. Return cover and secure.

9.8 PLANNED MAINTENANCE TASKS

TABLE 9-1: PLANNED MAINTENANCE TASKS

Task	Recommended action
Inspect	Implement a periodic inspection program to ensure all parts are free from damage due to process, ambient or other abnormal conditions. <ul style="list-style-type: none"> • Internal components: rotor, upstream to downstream cone, etc. • Meter body housing, external flanges, flamepath. • Bolting • Electrical connections.
Clean	Use a non-toxic metal cleaning solvent. Do not use common petrochemical solvents like Benzene, Toluene or Xylene as they can pose potential health hazards.
Monitor corrosion / erosion / wear	A careful review of turbine meter proving history, such as turbine meter factor control charts, can reveal potential problems with turbine meter measurements. Examples include bearing drag due to wear or an increased internal cross-sectional area due to erosion.

10 CORRECTIVE MAINTENANCE

10.1 TURBINE METER TROUBLESHOOTING

Use the table below to troubleshoot the turbine meter. Contact the nearest Daniel service office for repairs. It is important that servicing be performed by trained and qualified service personnel.

TABLE 10-1: TROUBLESHOOTING

Condition	Probable cause	Correction(1)
No output pulses from amplifier module	Input voltage to amplifier below minimum required for operation	Apply correct voltage (10 - 30 VDC)
	Damaged or shorted pickoff (Resistance across leads should be 600-900 Ohm)	Replace pickoff
	Damaged amplifier module	Replace amplifier module
	Customer receiver unit not operating	Contact Daniel Flow customer service
	Meter rotor not turning	Troubleshoot internal assembly
Turbine meter rotor not turning	Defective rotor bearing	Return rotor assembly to factory for replacement or repair
	Rotor damaged by foreign material passing through turbine meter	Return rotor assembly to factory for replacement or repair
Inaccurate readout	Foreign material on rotor blades	Check and clean blades
	Rotor blades are bent	Return to factory for replacement or repair
	Defective accessory equipment	Troubleshoot equipment

(1) * Refer to Prepare for mechanical disassembly for disassembly procedures.

10.2 VERIFY THE RETURN TO OPERATIONAL CONDITION

After correcting maintenance issues, verify that the turbine meter is working properly by following the steps below.

Procedure

1. Inspect all electrical connections to ensure compliance with electrical codes and safety regulations.
2. Inspect all flange bolts used to secure the turbine meter in-line to ensure that correct mounting procedures are followed and that flange connections are leakfree.
3. Evaluate the system setup to ensure that all components are in the correct sequence for accurate product measurement: isolation valve, strainer, flow straightener, turbine meter, downstream section, control valve, etc.
4. Ensure that the supply voltage to the preamplifier is within the 10-30 VDC range.

11 SPARE PARTS

11.1 RECOMMENDED SPARE PARTS

The figure below identifies the spare parts for an LME assembly.

FIGURE 11-1: PART IDENTIFICATION FOR A STANDARD ENCLOSURE

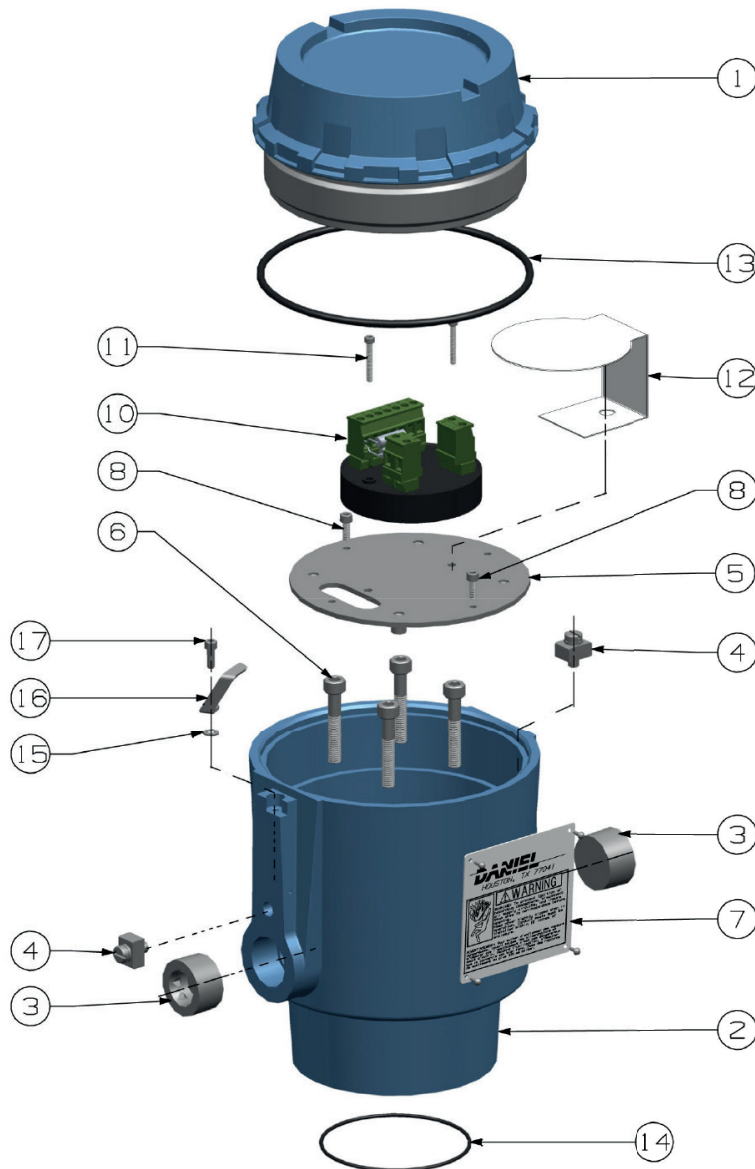

TABLE 11-1: RECOMMENDED SPARE PARTS FOR AN LME ASSEMBLY (STANDARD)

Item number	Description	Part number	Quantity required
10(1)	2818 Dual channel preamplifier	1-504-05-550	1
10(1)	2415 Intrinsically safe preamplifier	1-504-05-449	1
10(1)	1815B Zero crossing preamplifier	1-504-05-510	1
10(1)	1817X Bidirectional preamplifier	1-504-05-442	1
13	O-ring FKM	2-4-9163-245	1
14	O-ring FKM	1500093-022	1
41	Pickoff	899-00-201-00	2

(1) Refer to Interface parameters for detailed preamplifier information.

Refer to LME assembly - Standard enclosure.

Order spare parts

Contact Daniel Flow customer service and provide the following information when ordering spare parts:

- Turbine meter serial number
- Part number
- Part description
- Quantity

12 DECOMMISSION THE TURBINE METER

12.1 SHUT DOWN THE TURBINE METER

Follow the steps below to shut down and disassemble the turbine meter for storage or shipment.

**⚠ WARNING
PRESSURE HAZARD**

The turbine meter is subject to pressurized fluids. Depressurize the turbine meter before disassembly.

Failure to comply may cause high pressure fluids to leak, resulting in death or serious injury.

Procedure

1. Disconnect all power to the turbine meter and vent all line pressure.
2. Remove security wire.
3. Remove screws and top cover of the LME.
4. Disconnect wire connections from LME.
5. Disconnect the grounding cables.
6. Disconnect conduit connections to the turbine meter.
7. Remove turbine meter from line. Refer to Lifting conditions, Lifting requirements for personnel, and Safety precautions using appropriately rated lifting slings for instructions on how to lift the turbine meter.

12.2 TURBINE METER DISASSEMBLY/ASSEMBLY

Follow the recommendations below before disassembling the turbine meter for storage or assembling it for shipment.

- Label all parts or place parts in labeled containers during disassembly.
- Do not use metal clamping devices in direct contact with any turbine meter part or surface.
- Rotor blades determine accurate flow measurement and should be handled with extreme care. Bending or altering the blades in any way can affect turbine meter accuracy.

Thoroughly clean the turbine meter inside the housing components and store or ship as it was received. Refer to Pack the turbine meter.

After the meter is shut down, refer to Electronics enclosure disassembly and Electronics enclosure assembly for the detailed disassembly/assembly procedures.

12.3 SHIPMENT OF THE METER

Refer to the Daniel Flow customer service information in the preface of this document.

With over 90 years of experience, Daniel is the only manufacturer that has the knowledge and experience to engineer and offer superior products that are trusted to provide the most reliable and accurate measurements in the global oil and gas industry.

Contact Us

Email: sales@Daniel.com
Phone: +1 (346) 509-3700

www.Daniel.com



Decades Proven. Field Chosen.™