

DANIEL® LIQUID TURBINE METER PRODUCT GUIDE

SERIES 1200



DANIEL®
Decades Proven. Field Chosen.™

A RANGE OF AVAILABLE OPTIONS

FIGURE 1: DANIEL® 1200 LIQUID TURBINE FLOW METER



- DN25 to DN100 (1-in. to 4-in.) line sizes
- Stainless or carbon steel meter body
- NACE MR0175-compliant construction
- Single or dual LME in stainless steel

SERIES 1200 LIQUID TURBINE FLOW METER DURABILITY FOR SUSTAINED PERFORMANCE

Achieving highly accurate volumetric flow measurement of liquid hydrocarbons requires technology that ensures linearity and repeatability. Load rack and marketing terminal operators worldwide rely on the Daniel® Series 1200 Liquid Turbine Meter for reliable measurement during custody transfer and batch or in-line blending operations. Designed for demanding applications, the field-proven meter now features potted electronics along with rugged internals to provide steady, long-term performance.

The meter’s simple configuration and self-cleaning flow-through bearing design enable higher flow rates and an extended flow range, particularly on light hydrocarbons and light crude products. In addition, all DN40 (1.5-in.) meters and larger can be equipped with an optional integral flow conditioning plate that often eliminates the need for traditional flow conditioning methods. The plate allows for vertical installation when space is at a premium. An expanding hanger suspension system and positive rotor centering further ensure the meter is equally effective in a vertical orientation.

Another key advantage is the meter’s local mounted enclosure (LME) that can be configured with one or two pickoff coils and a standard dual-channel preamplifier. The combination of these components ensures total pulse integrity, virtually eliminating the potential for missing or double-counted pulses.

API COMPLIANT

The Series 1200 Liquid Turbine Flow Meter is specifically designed for pipeline operation and for use within the guidelines of the API Manual of Petroleum Measurement Standards (MPMS), Chapter 5.3 (Measurement of Liquid Hydrocarbons by Turbine Meter) and the calibration procedures of MPMS, Chapter 4 (Proving Systems).

TYPICAL APPLICATIONS

- Refined product loading/unloading.
- Batch/in-line blending operations.

FEATURES AND BENEFITS

- Pulse output linear with flow rate and 10:1 rangeability (turndown) ensure custody transfer and fiscal measurement accuracy.
- High-frequency pulse resolution enables measurement of minute increments of flow rate for greater accountability
- Stainless steel internal assembly ensures maximum volume throughput and minimum pressure drop
- Stainless steel ball or tungsten journal carbide bearings guarantee durability and longevity with minimal maintenance required.
- Local mounted enclosure (LME) configured with one or two pickoffs and a standard dual-channel preamplifier for total pulse integrity.
- Electronics designed for easy access to pickoffs and preamplifier to simplify service
- LME aluminum or stainless steel (optional) housing is explosion and weather proof for safe operation within refineries and harsh environments.

STANDARD SPECIFICATIONS

The standard performance parameters and materials of construction are noted. Additional product and material offerings may be available depending on the application. Please consult with a Daniel® product specialist to confirm.

PROCESS PARAMETERS

TABLE 1: PROCESS TEMPERATURE RANGE

	Carbon steel	304/316 Stainless
Standard	-29°C to +60°C (-20°F to +140°F)	-40°C to +60°C (-40°F to +140°F)

TABLE 2: LINEARITY

Size		Standard linearity	Premium linearity	Repeatability(1)
DN	Inches			
25 to 50	1 to 2	±0.25%	±0.15%	±0.02%
80 to 100	3 to 4	±0.15%	N/A	±0.02%

(1) The repeatability of Turbine Meters can only be demonstrated under specific calibration conditions which involve the uncertainty of the laboratory. For specific details, contact your Daniel® local representative.

TABLE 3: FLANGE PRESSURE RATINGS (METRIC UNITS)



PN	Pressure rating, barg @ 38°C	
	Carbon steel	304/316 Stainless
20	19.7	19.0
50	51.0	49.6

TABLE 4: FLANGE PRESSURE RATINGS (US CUSTOMARY UNITS)

ANSI	Pressure rating, psig @ 100°F	
	Carbon steel	304/316 Stainless
150	285	275
300	740	720

SAFETY AND COMPLIANCE

Electrical

- UL / cUL Class I, Division 1, Groups B, C and D
- ATEX:  II 2 G Ex db IIB T6 Gb
 II 2 G Ex db IIC T6 Gb
- IECEx: Ex db IIB T6 Gb
Ex db IIC T6 Gb
- INMETRO: Ex db IIC T6 Gb

Environmental

- Stainless steel: NEMA 4X (IEC IP66)

Pressure Equipment

- Pressure Equipment Directive (PED): CE 828337
- Pressure Equipment (Safety) Regulations: UKCA 828334

Metrology

- NMI TC7573, revision 6
- Measurement Canada, AV-2264

ELECTRICAL FEATURES

PREAMPLIFIERS

The local mounted enclosure (LME) on the Daniel® Series 1200 Liquid Turbine Meter contains a standard dual-channel pre-amplifier and two inductive pickoff coils. These coils have the sensitivity to provide accurate detection of rotor travel and have output with electrical characteristics of high impedance and low voltage. Noise-free transmission of the flow signals requires the opposite: low impedance and high voltage. This is the function of the signal preamplifier. Located within 5 meters (16.4 feet) of the pickoff coil, turbine meter preamplifiers shape, and condition the pickoff output signal, rendering it suitable for transmission over distances of up to 914 meters (3,000 feet).

Environmental

The Model 2818 Dual Channel Preamplifier is the standard Daniel® offering for the Series 1200 meter. The signals from two inductive pickoff coils, positioned 90° electrically out of phase, are strengthened and conditioned by a single pre-amplifier. Fully potted in Delrin® resin, the Model 2818 preamplifier has three possible outputs: powered pulse, variable voltage, and open collector.

ELECTRICAL PERFORMANCE

Pickoff specifications

- Type: 2-wire reluctance.
- Resistance: 600 to 900 ohms.
- Inductance: 250mH max.
- Output: Sinusoidal 40mV p-p minimum @minimum flow with preamplifier load.
- Optional: 2 pickoff coils (single or dual LME) or 4 pickoff coils (dual LME required).

STANDARD PREAMPLIFIER

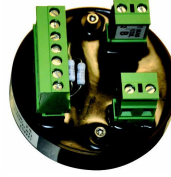

MODEL #	2818
Daniel® Part #	1-504-05-550
INPUTS	
# of Inputs (Pickoffs):	1 or 2
Supply Voltage:	10 to 30 Vdc
Sensor Type:	Reluctance
Signal:	Sine Wave
Current:	10 to 30 Vdc @ 40 mA _{p-p}
Preamplifier Sensitivity:	40 mV _{pp}
Frequency Response:	0 to 5 kHz
OUTPUTS (POWERED PULSE)	
Type:	Square wave
Frequency Range:	≤ 0 to 5 kHz
Amplitude:	0 to 5V
Impedance:	1000 Ohm, 20 mA max
Construction	Delrin housing Solid epoxy encapsulation
Temperature Range	-40°F to +85°F (-40°C to +185°C)
CUSTOMER CONNECTION	
Temperature Range	(1) +10 to 30 VDC (2) Common (3) Common (4) Channel A Output (5) Channel B Output (6) TTL Out A (7) TTL Out B
PICKOFFS	
Channel A (TB2):	(1) White (2) Red
Channel B (TB3):	(1) White (2) Red

STANDARD FLOW RANGES

The flow rate must fall within the minimum and maximum linear flow rate to meet the standard and premium linearity specification. Table 7, Table 8 and Table 9 represent the effect of specific gravity on the linear flow range.

TABLE 5: LINEAR FLOW RANGE

Nominal Size		BBL/HR			M3/HR			USG/PM		
DN	Inches	Standard Flow Range		Extended Max Flow Rate(2)	Standard Flow Range		Extended Max Flow Rate(1)	Standard Flow Range		Extended Max Flow Rate(1)
		Min	Max		Min	Max		Min	Max	
25	1	8.6	86	99	1.4	14	16	6	60	69
40	1.5	19	186	214	3.0	30	34	13	130	150
50	2	31	314	361	5.0	50	58	22	220	253
80	3	93	929	1,068	15	148	170	65	650	748
100	4	143	1,429	1,785	23	227	284	100	1,000	1,250

(1) Extended maximum flow range with 20% duty cycle not to exceed 2 hours per day

TABLE 6: NOMINAL K-FACTOR

Nominal Size		K-Factor(1)		
DN	Inches	Pulses/BBL	Pulses/M3	Pulses/USG
25	1	33,600	211,338	800
40	1.5	16,800	105,669	400
50	2	7,560	47,551	180
80	3	2,184	13,737	52
100	4	966	6,076	23

(1) K-Factors for individual rotors vary. An acceptable rotor can be nominal $\pm 15\%$.

TABLE 7: FLOW RANGE ADJUSTMENTS FOR SPECIFIC GRAVITY = 0.7 TO 1 (BLADE TYPE INTERNALS ONLY)

Nominal Size		Minimum Linear Flow Rate			Maximum Linear Flow Rate		
DN	Inches	BBL/HR	M3/HR	USGPM	BBL/HR	M3/HR	USGPM
25	1	8.6	1.4	6.0	86	14	60
40	1.5	19	3.0	13	186	30	130
50	2	31	5.0	22	314	50	220
80	3	93	15	65	929	148	650
100	4	143	23	100	1,429	227	1,000

TABLE 8: FLOW RANGE ADJUSTMENTS FOR SPECIFIC GRAVITY = 0.6 (BLADE TYPE INTERNALS ONLY)

Nominal Size		Minimum Linear Flow Rate			Maximum Linear Flow Rate		
DN	Inches	BBL/HR	M3/HR	USGPM	BBL/HR	M3/HR	USGPM
25	1	14	2.3	10	99	16	69
40	1.5	31	5.0	22	214	34	150
50	2	53	8.4	37	361	58	253
80	3	156	25	109	1,071	170	750
100	4	239	38	167	1,786	284	1,250

TABLE 9: FLOW RANGE ADJUSTMENTS FOR SPECIFIC GRAVITY = 0.5 (BLADE TYPE INTERNALS ONLY)

Nominal Size		Minimum Linear Flow Rate			Maximum Linear Flow Rate		
DN	Inches	BBL/HR	M3/HR	USGPM	BBL/HR	M3/HR	USGPM
25	1	20	3.2	14	99	16	69
40	1.5	44	7.0	31	214	34	150
50	2	74	12	52	361	58	253
80	3	219	35	153	1,071	170	750
100	4	336	53	235	1,786	284	1,250

PRESSURE DROP

The pressure drop characteristics on water for the Series 1200 Liquid Turbine Meter by line size.

FIGURE 2: PRESSURE DROP CHART

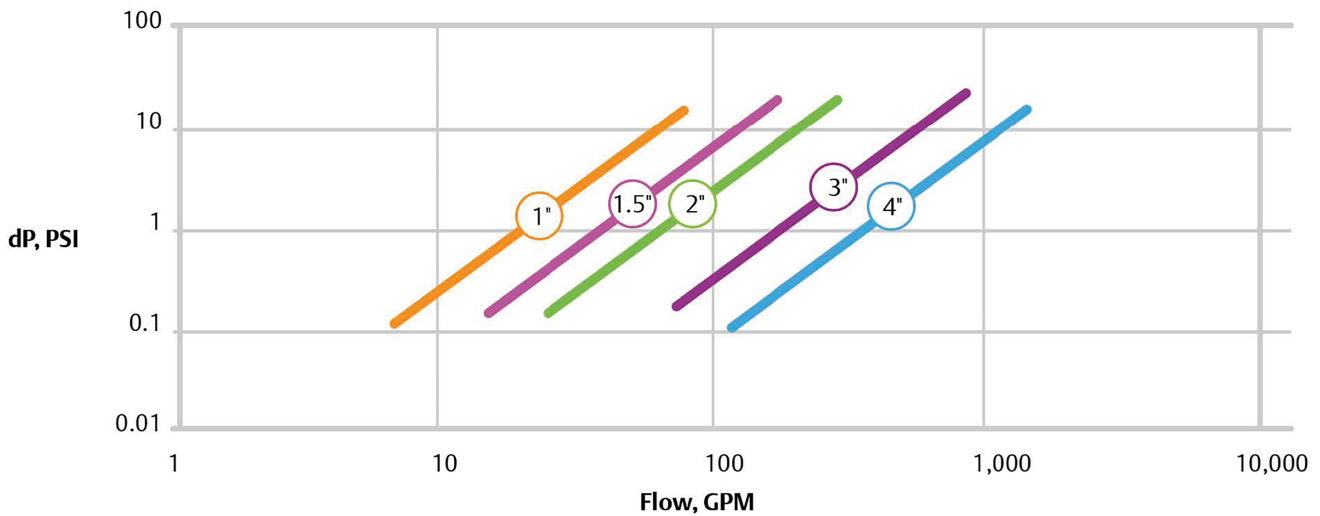

TABLE 10: SERIES 1200 PRESSURE DROP (METRIC UNITS)

Flow Range		No conditioner		Integral flow conditioner							
		DN25		DN40		DN50		DN80		DN100	
		M3/H	mBar	M3/H	mBar	M3/H	mBar	M3/H	mBar	M3/H	mBar
Standard flow range	Minimum	1.36	7.7	2.95	9.4	5	9.5	14.8	11.0	22.7	6.6
	Maximum	13.6	765	29.5	938	50	952	148	1,096	227	655
Extended maximum		16	11,007	34	1,248	58	1,255	170	1,462	284	1,020

TABLE 11: SERIES 1200 PRESSURE DROP (US CUSTOMARY UNITS)

Flow Range		No conditioner		Integral flow conditioner							
		1-in.		1.5-in.		2-in.		3-in.		4-in.	
		GPM	dP	GPM	dP	GPM	dP	GPM	dP	GPM	dP
Standard flow range	Minimum	6	0.111	13	0.136	22	0.138	65	0.159	100	0.095
	Maximum	60	11.1	130	13.6	220	13.8	650	15.9	1,000	9.5
Extended maximum		69	14.6	150	18.1	253	18.2	750	21.2	1,250	14.8

PRODUCT DIAGRAMS

Local Mounted Enclosure (LME)

FIGURE 3: LOCAL MOUNTED ENCLOSURE (LME) WITH STANDARD DUAL-CHANNEL PREAMPLIFIER

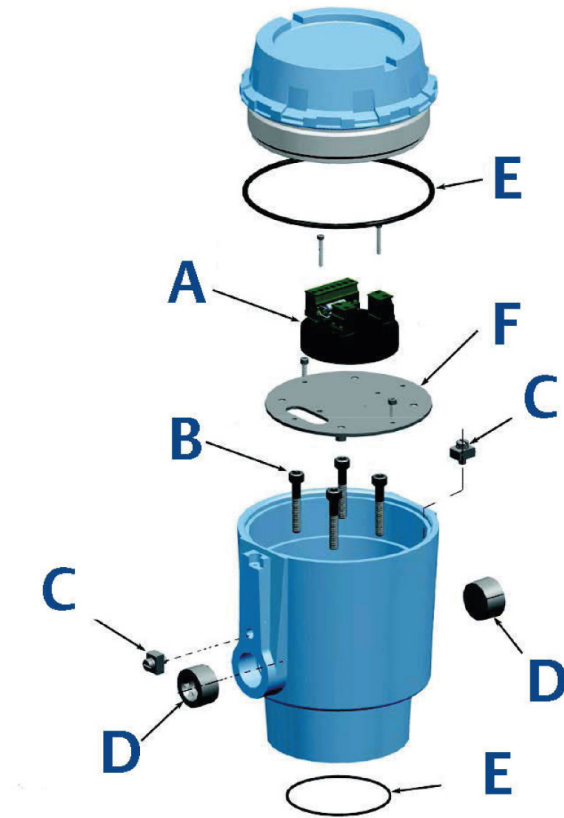

- A. Dual-channel preamplifier
- B. Socket head screws
- C. Grounding cap
- D. Plug pipe hex socket
- E. O-ring
- F. Mounting bracket

Internal with stainless steel bearing

FIGURE 4: INTERNAL ASSEMBLY FOR A NOMINAL PIPE SIZE DN80 TO DN100 (3-IN TO 4-IN) LIQUID TURBINE METER

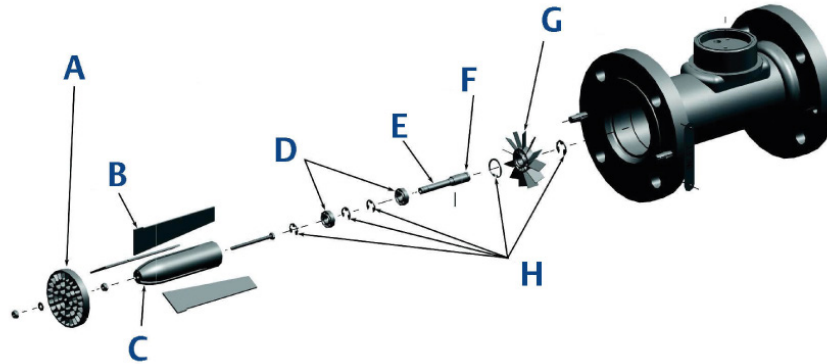

- A. Flow conditioning plate
- B. Fins
- C. Diffuser
- D. Stainless steel ball bearing
- E. Roll pin
- F. Shaft
- G. Rotor assembly
- H. Retaining rings

Internals with tungsten carbide bearings

FIGURE 5: INTERNAL ASSEMBLY FOR A NOMINAL PIPE SIZE DN80 TO DN100 (3-IN TO 4-IN) LIQUID TURBINE METER

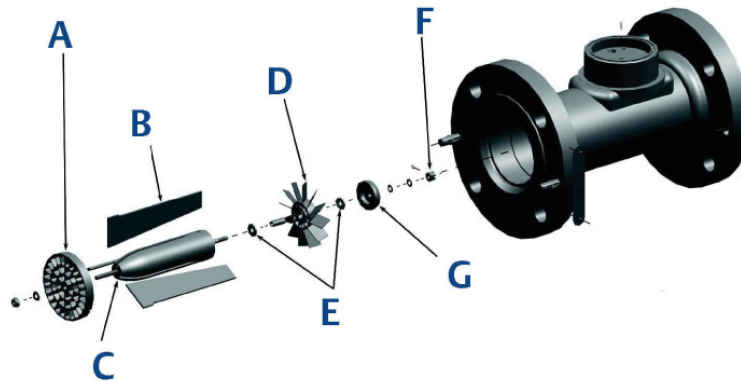

- A. Flow conditioning plate
- B. Fins
- C. Diffuser
- D. Rotor assembly
- E. Thrust washers
- F. Cotter pin
- G. Outlet diffuser cap

MATERIALS OF CONSTRUCTION

TABLE 12: METER WITH STAINLESS STEEL BEARINGS (DN25 TO DN100/1-IN. TO 4-IN.)

Description	Standard	NACE MR0175:2003 Compliant
Meter body and flanges		
DN25 to DN40 (1-in. to 1.5-in.)	304SS Only	304SS Only
DN50 to DN100 (2-in. to 4-in.)	Carbon steel or 304SS	Carbon steel or 304SS
Local Mounted Enclosure (LME)	Aluminum/316SS	Aluminum/316SS
Rotor hub/rotor blades		
DN25 to DN40 (1-in. to 1.5-in.)	17-4PH	430SS
DN50 to DN100 (2-in. to 4-in.)	Aluminum 6061-T6/430SS	Aluminum 6061-T6/430SS
Retaining ring		
DN25 to DN40 (1-in. to 1.5-in.)	302SS	302SS
DN50 to DN100 (2-in. to 4-in.)	N/A	N/A
Bearing spacer		
DN25 to DN50 (1-in. to 2-in.)	302SS	302SS
DN80 to DN100 (3-in to 4-in)	N/A	N/A
Shaft		
DN25 (1-in.)	303SS	303SS
DN40 to DN50 (1.5-in. to 2-in.)	304SS	304SS
DN80 (3-in.)	Aluminum 6061-T6	Aluminum 6061-T6
DN100 (4-in.)	Aluminum 2011-T3	Aluminum 2011-T3
Bearing Set	Stainless steel	Stainless steel
Suspension Blade		
DN25 (1-in.)	304SS	304SS
DN40 to 100 (1.5-in. to 4-in.)	Aluminum 2024-T3	Aluminum 2024-T3
Suspension diffuser		
DN25 (1-in.)	316SS	316SS
DN40 to DN100 (1.5-in. to 4-in.)	Aluminum 6061-T6	Aluminum 6061-T6
Downstream cone		
DN25 (1-in.)	N/A	N/A
DN40 to DN100 (1.5-in. to 4-in.)	303SS	303SS
Sleeve		
DN25 (1-in.)	304SS	304SS
DN40 to DN100 (1.5-in. to 4-in.)	N/A	N/A
Flow conditioning plate		
DN25 (1-in.)	N/A	N/A
DN40 to DN100 (1.5-in. to 4-in.)	Delrin	N/A
DN80 to DN100 (3-in to 4-in)	Delrin/Aluminum	Aluminum

TABLE 13: METER WITH TUNGSTEN CARBIDE BEARINGS (DN 80 TO 100/3-IN. TO 4-IN.)

Meter body and flanges	Carbon steel or 304SS	Carbon steel or 304SS
Local Mounted Enclosure (LME)	316SS	316SS
Rotor hub/rotor blades	Aluminum 6061-T6/430SS	Aluminum 6061-T6/430SS
Shaft	303SS	303SS
Bearing set	Tungsten carbide	Tungsten carbide
Suspension blade	Aluminum 2024-T3	Aluminum 2024-T3
Suspension diffuser	Aluminum 6061-T6	Aluminum 6061-T6
Diffuser washer	Aluminum 6061-T6	Aluminum 6061-T6
Flow conditioning plate	Delrin/Aluminum	Aluminum

WEIGHTS AND DIMENSIONS

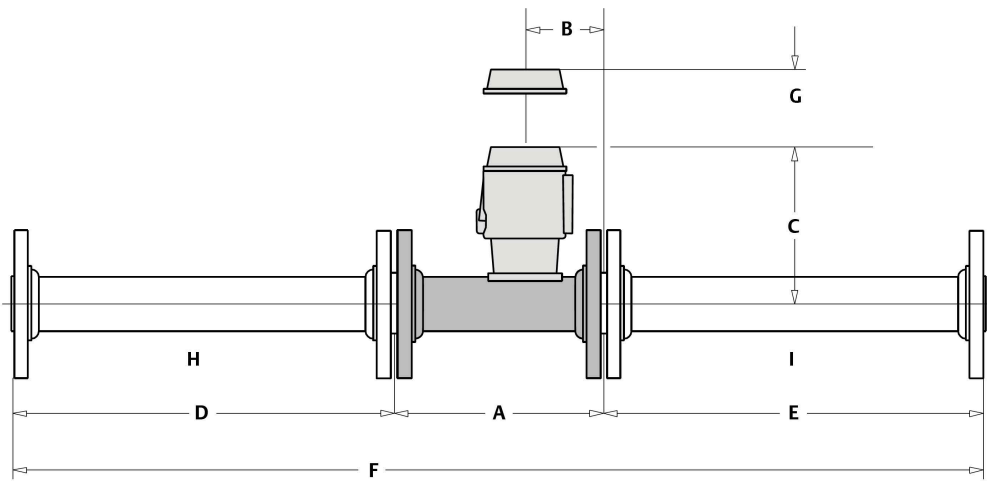

- A. See Table 14
- B. See Table 14
- C. See Table 14
- D. See Table 14
- E. See Table 14
- F. See Table 14
- G. 5-in. (127.0 mm) minimum distance requirements for service
- H. Upstream spool (optional)
- I. Downstream spool (optional)

TABLE 14: DIMENSIONAL DATA FOR DANIEL® SERIES 1200 LIQUID TURBINE FLOW METER AND FLOW STRAIGHTENING SECTIONS

Nominal Size		A		B		C		D		E		F	
DN	Inches	mm	Inches	mm	Inches	mm	Inches	mm	Inches	mm	Inches	mm	Inches
25	1	203	8	102	4	259	10	508	20	127	5	841	33
40	1.5	229	9	114	4.5	269	11	191	8	191	8	613	24
50	2	229	9	114	4.5	269	11	254	10	254	10	740	29
80	3	254	10	127	5	279	11	381	15	381	15	1,022	40
100	4	305	12	152	6	297	12	508	20	508	20	1,324	52

TABLE 15: SHIPPING WEIGHT – WEIGHT BASED ON TURBINE METER ONLY. FOR SINGLE STAINLESS STEEL LME ADD 3.75 KG (8.3 LB.). FOR DOUBLE LME'S, ADD 7.5 KG (16.6 LB.).

Nominal Size		ANSI 150		ANSI 300	
DN	Inches	kg	lbs	kg	lbs
25	1	10.5	23	10.5	23
40	1.5	11.8	26	14.6	32
50	2	13.7	30	17.5	32
80	3	19.1	42	23.2	51
100	4	25.9	57	33.6	74

ORDERING INFORMATION

DEVICE	
Code	Device
TM12	Series 1200 Turbine Flow Meter

Code	Case option
01	1-in (DN25) / 7-70 GPM, 10-100 BHP, 1.6-16 M ³ /H
15	2-in. (DN50)/30-300 GPM, 43-429 BHP, 6.8-68 M ³ /H
02	2-in. (DN50)/30-300 GPM, 43-429 BHP, 6.8-68 M ³ /H
25	2.5-in (DN65) / 40-400GPM, 57-571 BHP, 9.1-91M ³ /H
03	3-in (DN80) / 70-700 GPM, 100-1000 BHP, 15.9-159 M ³ /H
04	4-in (DN100) / 130-1295 GPM, 185-1850 BHP, 29.4-294 M ³ /H

PRESSURE RATING	
Code	Description
01	ANSI 150 / 285 PSI MWP, RF Flange / 1-in (DN25) to 24-in (DN600)
03	ANSI 300 / 740 PSI MWP, RF Flange / 1-in (DN25) to 24-in (DN600)
16	PN 16 / 16 BAR MWP, RF Flange / DN25 (1-in) to DN600 (24-in)
25	PN 25 / 25 BAR MWP / DN25 (1-in) to DN600 (24-in)
40	PN 40 / 40 BAR MWP / DN25 (1-in) to DN600 (24-in)

FLANGE TYPE	
Code	Description
A	RF Slip On (125-250 AARH)

NACE	
Code	Case option
A	No
B	Yes

BODY AND FLANGE MATERIAL

Code	Description
F1	Carbon steel
F2	304 Stainless steel

METER INTERNAL MATERIALS

Code	Case option
1	304 Stainless steel
2	Aluminum

BEARING

Code	Case option
1	Ball bearing
2	Tungsten carbide bearing

ROTOR TYPE

Code	Case option
1	Standard rotor
2	PTFE coated rotor

ENCLOSURE MATERIAL

Code	Case option
B	316 Stainless steel

METER OUTPUT

Code	Case option
1	1 Pick-Off with 1 Dual Channel Preamp Model 2818
2	2 Pick-Offs with 1 Dual Channel Preamp Model 2818

TAGGING FORMAT (NAMEPLATE)

Code	Description
1	Inch / ANSI / US Customary
2	Inch / ANSI / Metric
3	DN / PN / US Customary
4	DN / PN / Metric

APPROVALS

Code	Certification
A	CCA/UL/CU
B	CE (includes ATEX, PED, or SEP, and EMC), IECEx
C	INMETRO

METER LINEARITY

Code	Description
C	Standard ($\pm 0.25\%$ 1-in. -2-in., $\pm 0.15\%$ 3-in.- 4-in.)
D	Premium ($\pm 0.15\%$ 1-in. -2-in.)

DISPLAY MOUNT

Code	Case option
A	None
C	External

DISPLAY

Code	Case option
A	None
B	Electronic Display (4-20 Loop)
C	Electronic Display (MODBUS - 24vDC)

FLOW DIRECTION

Code	Description
A	Horizontal, no flow conditioning plate
B	Vertical, no flow conditioning plate
C	Horizontal, flow conditioning plate
D	Vertical, no flow conditioning plate
F	Horizontal, aluminum flow conditioning plate
G	Vertical, aluminum flow conditioning plate

METROLOGY APPROVAL

Code	Description
1	Unspecified
2	NTEP, CC: 90-118, For 1.5-in. meter: 6 - 130 GPM
3	Measurement Canada, AV-2264, 5:1 turndown for diesel fuel and stove oil

AGENCY CERTIFICATIONS FOR THE SERIES 1200 LTM

TABLE 16: AGENCY CERTIFICATIONS FOR THE SERIES 1200 LTM

Certification type		Description	Certificate
Electrical	UL and CUL	Class I, Div. 1, Groups B, C & D	E202815
	ATEX	⊕ II 2 G Ex db IIB T6 Gb ⊕ II 2 G Ex db IIC T6 Gb	DEMKO 03 ATEX 130946X Rev. 10
	IECEX	EX db IIB T6 Gb. EX db IIC T6 GB.	IECEX UL 11.0031X Rev 10
	INMETRO	Ex db IIC T6 Gb	NCC 23.0046 X rev 0
Environmental		NEMA 4x (IP66).	DEMKO 03 ATEX 130946X Rev. 10
Metrology		MID / OIML R117-1	TC7573 Rev. 6
Ambient temperature		-40 °C to 60 °C (-40 °F to 140 °F).	

With over 90 years of experience, Daniel is the only manufacturer that has the knowledge and experience to engineer and offer superior products that are trusted to provide the most reliable and accurate measurements in the global oil and gas industry.

Contact Us

Email: sales@Daniel.com
Phone: +1 (346) 509-3700

www.Daniel.com

