

DANIEL[®] DIGITAL CONTROL VALVES PRODUCT GUIDE

SERIES 700 - MODEL V788

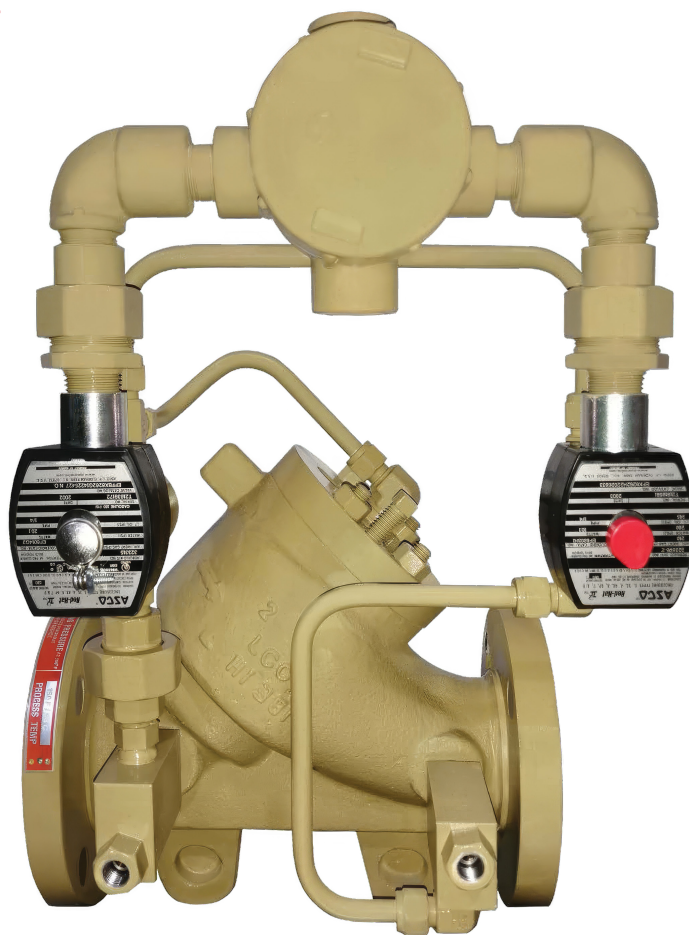

DANIEL[®]
Decades Proven. Field Chosen.[™]

DANIEL® 788 DIGITAL CONTROL VALVE

OVERVIEW

The Daniel® 788 Digital Control Valve is designed to provide precise flow rate control and batch delivery of fluids when integrated with an electronic batch control device (preset).

The Daniel® 788 Digital Control Valve is automatically controlled by the preset for low flow start-up, high flow rate control, low flow shutdown, and final shut off. This valve also provides for maximum flowmeter accuracy by maintaining a constant flow rate with varying line pressures. The Daniel® 788 Digital Control Valve features an external pilot control loop that consists of a normally open solenoid pilot, a normally closed solenoid pilot, strainer and opening/closing speed controls.

APPLICATIONS

The Daniel® 788 Digital Control Valve can be used in any application requiring precise flow rate control with batch capability when used with an electronic preset capable of digital valve control including loading and off-loading (truck, railcar, ship, barge, etc).

FEATURES AND BENEFITS

- Precise flow rate and batch control
- Modular construction – All internal parts including seat and seat ring may be removed as a cartridge assembly without the need to remove the valve body from the system piping
- No diaphragms or stuffing boxes
- 45° body design assures high capacity and low pressure drop
- Positive (bubble tight to Class VI) shut-off
- Linear control characteristics with uniform response speed
- Fail-safe closure on loss of power
- Aggressive Products (AP) Option with Teflon® elastomers

FIGURE 1: DANIEL™ 788 DIGITAL LIQUID CONTROL VALVE



STANDARD SPECIFICATIONS

Please consult Daniel® if your requirements are outside the specifications noted below. Other product and material offerings may be available depending on the application.

FLANGE CONNECTIONS / RATINGS (ANSI)

Valve size: 2" to 8"

Maximum working pressure at 38°C

ANSI 150: 285 psi (1,964 kPa)

ANSI 300: 740 psi (5,099 kPa)

Temperature Range: -20°F to 150 °F (-29°C to 66°C)

Optional 250°F (121°C)

FLANGE CONNECTIONS / RATINGS (DIN)

Valve size: DN50 - DN200

Maximum working pressure at 38 °C

DIN PN16 MWP: 16 bar

DIN PN25 MWP: 25 bar

DIN PN40 MWP: 40 bar

DIN PN64 MWP: 51 bar

MATERIALS OF CONSTRUCTION

Main Valve Body:	2" 17 - 4 PH Stainless Steel 316/L Stainless Steel 3" - 8" 316/L Stainless Steel Carbon Steel, Nickel Coated
Main Valve Cylinder:	2" - 4" Stainless Steel Heat Threaded 17-4 PH 6" - 8" Carbon Steel, Nickel Coated
Main Valve Piston:	Stainless Steel
Seat Ring:	Stainless Steel 8" Carbon Steel, Nickel Coated
O-Rings:	Viton® (Standard) Available in Neoprene, EPR, Kalrez®, Teflon® ("AP" Valves) (Optional)
Other Internal Parts:	Stainless Steel
Pilot Valve Strainer / Needle Valve Trim:	Stainless Steel
Pilot O-rings:	Viton® (Standard) Available in Neoprene, EPR, Kalrez®, Teflon® ("AP" Valves) (Optional)
Tubing and Fittings:	Stainless Steel

VALVE CAPACITY

TABLE 1: VALVE CAPACITY

Valve Size	2"	3"	4"	6"	8"
Cv (GPM)	86	186	309	688	1,296

AVAILABLE SOLENOID PILOTS HAZARDOUS AREA CLASSIFICATIONS

- UL / CSA listed Solenoid:
 (Red-Hat I Solenoid)
 Class I, Div 1, Groups C & D
 Class II, Div 1, Groups E, F & G
 (Red-Hat II Solenoid)
 Class I, Div 1, Groups A, B, C &
 Class II, Div 1, Groups E, F & G
 Enclosure types 3, 3S, 4, 4X, 6, 6P, 7 & 9

AVAILABLE CONTROL VALVE CERTIFICATIONS:

- PED / PESR [or SEP]

MAXIMUM OPERATING PRESSURE DIFFERENTIAL (MOPD) ACROSS PILOTS

150 ANSI Standard

- 150 psid (1,035 kPa)
- 285 psid (1,967 kPa) (optional)

300 ANSI Standard

- 740 psid (5,106 kPa)

STANDARD EQUIPMENT

- Pre-wired solenoids (optional for CE execution)
- Opening and closing speed controls
- Self-cleaning strainer (pilot inlet)
- Stainless steel solenoid pilots
- Stainless steel tubing and fittings

OPTIONAL EQUIPMENT

- Pre-wiring for valves with CE solenoids
- Manual override
- Valve position indicator
- Thermal relief

AGGRESSIVE PRODUCTS OPTION

The use of aggressive additives or oxygenates call for the Aggressive Products, or AP option. The AP option valve cylinder incorporates cup-seals (Teflon® Bal Seals) and an O-ring made from appropriate materials for such challenging conditions. Materials for pilots such as low swell nitrile (main valve static O-rings) and Kalrez® or Teflon® are available.

APPROXIMATE SHIPPING WEIGHT AND VOLUME

TABLE 2: APPROXIMATE SHIPPING WEIGHT AND VOLUME

Valve Size	150 ANSI				300 ANSI			
	Shipping Weights		Shipping Volume		Shipping Weights		Shipping Volume	
	lbs	Kgs	Cubic Feet	Cubic Meters	lbs	Kgs	Cubic Feet	Cubic Meters
2"	60	27	1.7	.047	65	29	1.8	.050
3"	105	48	2.4	.067	115	52	2.5	.070
4"	140	64	2.5	.071	165	75	3.1	.087
6"	250	114	4.9	.137	290	132	6.0	.169
8"	400	181	8.9	.253	465	212	10.0	.283

DIMENSIONS

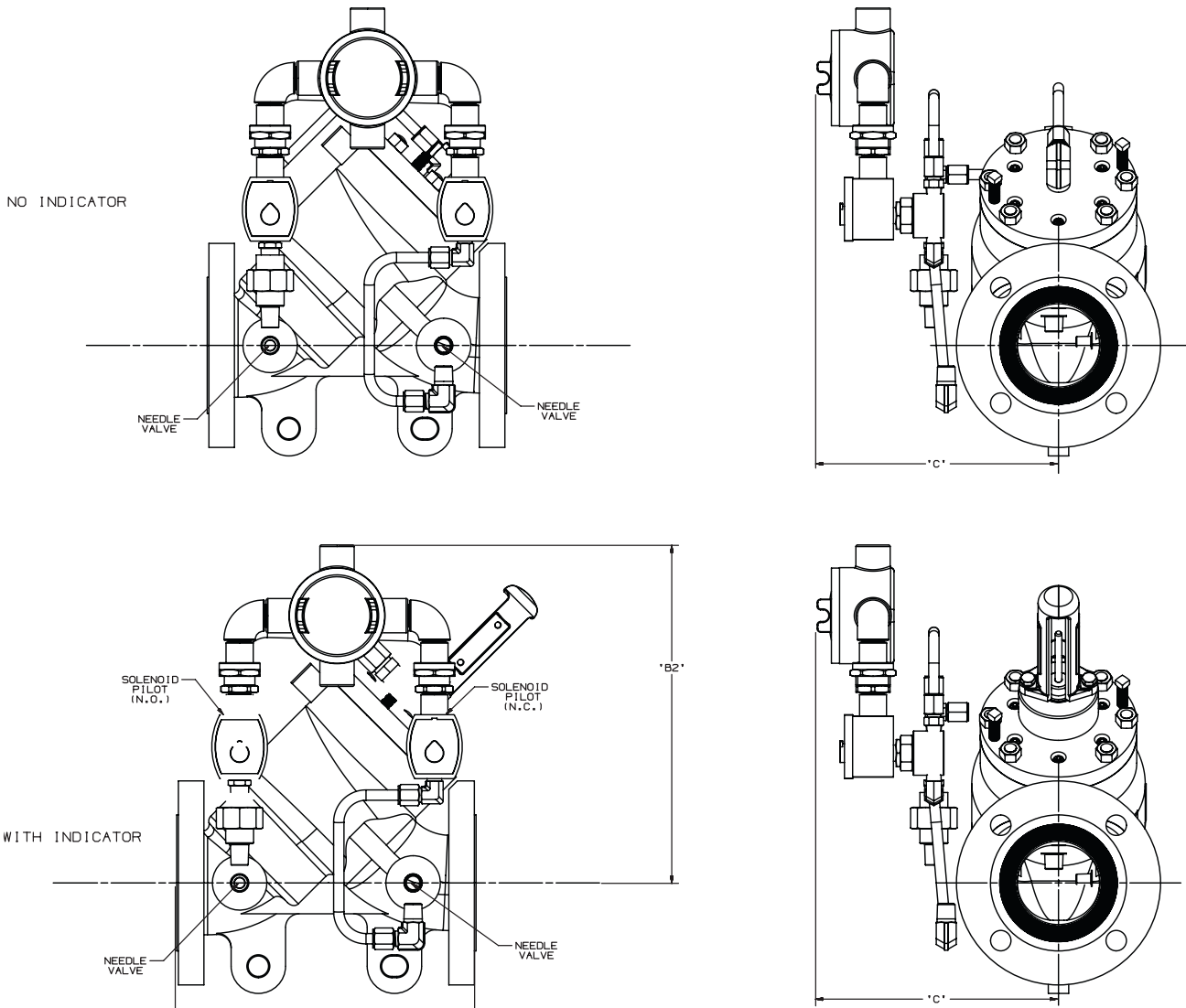

TABLE 3: DIMENSIONS

Valve Size	150 ANSI				300 ANSI			
	A	B ₁ No Indicator	B ₂ No Indicator	C	A	B ₁ No Indicator	B ₂ No Indicator	C
2"	10.25"	10.25"	11"	8.25"	10.5"	9"	11"	8.25"
	260 mm	229 mm	279 mm	210 mm	267 mm	229 mm	279 mm	210 mm
3"	11"	9"	12"	8.75"	13.125"	9"	12"	.050
	279 mm	229 mm	305 mm	222 mm	333 mm	229 mm	305 mm	.050
4"	13"	9"	12.5"	9"	14.5"	9"	12.5"	9"
	330 mm	229 mm	318 mm	229 mm	368 mm	229 mm	318 mm	229 mm
6"	17"	12"	15.75"	11"	17.875"	12"	15.75"	11"
	432 mm	305 mm	400 mm	279 mm	454 mm	305 mm	400 mm	279 mm
8"	22.25"	15"	17.5"	11.75"	23.25"	15"	17.5"	11.75"
	565 mm	381 mm	445 mm	298 mm	591 mm	381 mm	445 mm	298 mm

OPERATIONAL SEQUENCE*

With both solenoids de-energized, the main valve is closed. The main valve can be infinitely positioned anywhere between 0-100% open by digital control of the solenoids. With both solenoids energized, as shown in Figure 2, the valve begins to open. It will only open to the programmed flow rate set in the preset. Normally, the preset is programmed to digitally control low flow startup rate, maximum flow rate, low flow rate before shut-off and final shut-off. The preset will automatically energize and de-energize the solenoids to position the main valve to attain the required flow rate. When the required rates are reached the solenoids will be as shown in Figure 3. This hydraulically locks the main valve piston in position. Should flow increase, the valve will close slightly to adjust to the required rate. All of the positioning is done by digitally controlling the two solenoids as shown in Figures 1, 2 and 3. The valve opening and closing speeds can be adjusted independently via the two needle valves which are shown below.

CLOSED OR CLOSING POSITION –

The normally closed solenoid is closed. The normally open solenoid is open. Y-Port (P3) to Z-port (P2) is closed. X-port (P1) and Y-port (P3) pressures are balanced. The main valve spring, being the differential force, closes the piston and keeps it seated.

FIGURE 1

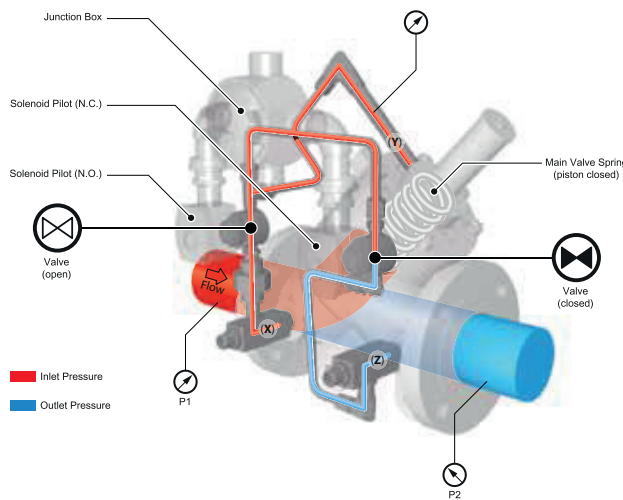

FULL OPEN / NO CONTROL –

The normally closed solenoid is open. The normally open solenoid is closed. Y-Port (P3) is open to Z-port (P2). X-port (P1) is closed off by the normally open solenoid. The pressure on the bottom of the piston (P1) is greater than the pressure at (P3) plus the spring force; $(P1 \text{ minus } P2)$ is equal to or greater than the spring force. Therefore, (P1) pressure pushes the piston open.

FIGURE 2

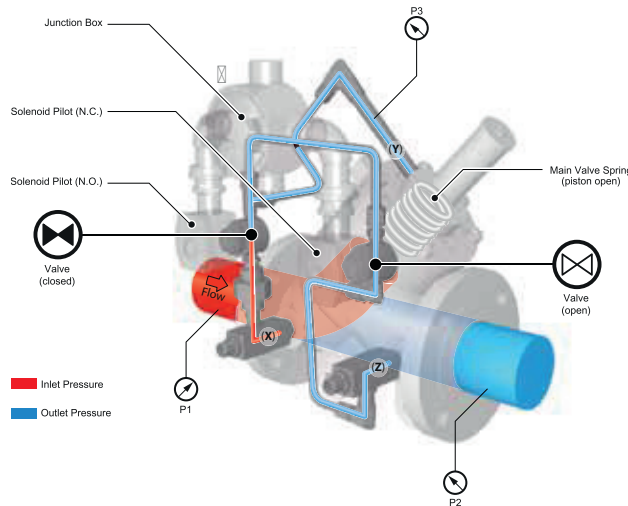

CONTROLLING POSITION –

The normally closed solenoid is closed. The normally open solenoid is closed. Y-Port (P3) to Z-port (P2) is closed. X-port (P1) to Y-port (P3) is closed. Note: The product cannot flow to or from the top of the piston (Y-port). The piston is hydraulically locked in position until the preset commands the valve to open or close as required to maintain the desired flow rate.

FIGURE 3

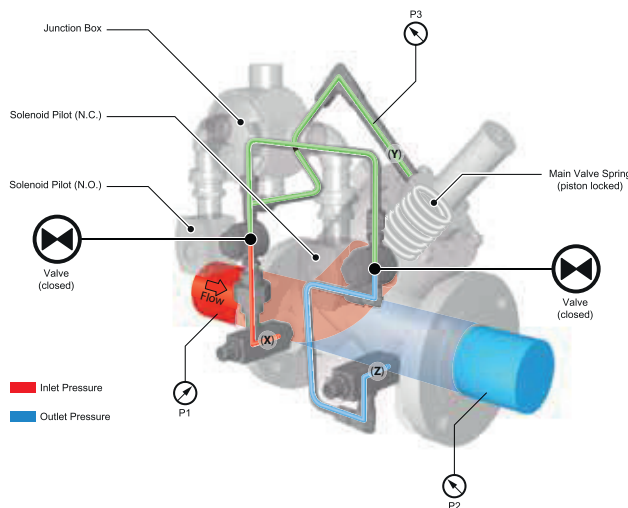

*Please refer to the Daniel 788 Digital Control Valve Operating and Maintenance Manual for all operating instructions and safety information.

TYPICAL APPLICATIONS

The most common application of the Daniel® Model 788 Digital Control Valve is for truck loading. The figure below shows the Daniel® 788 Digital Control Valve working with turbine meters and electronic preset to precisely control flow rates, batch quantities and blend ratio's of various products being loaded.

LOAD RACK INSTALLATION WITH DANIEL® 788 DIGITAL CONTROL VALVE FOR RATIO BLENDING

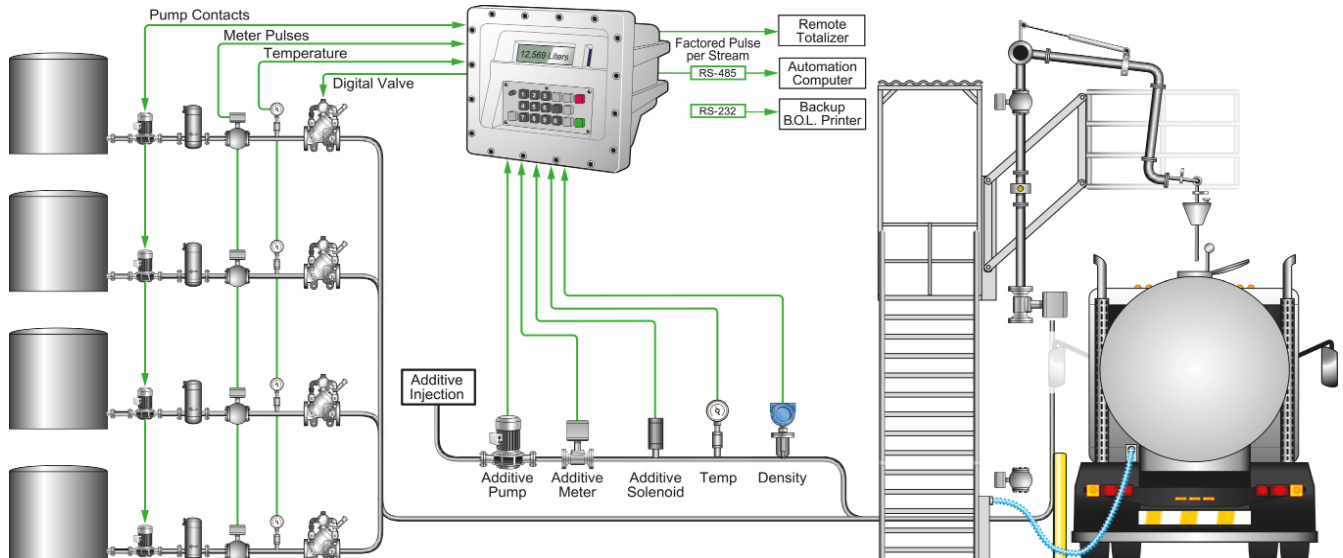

AGENCY CERTIFICATIONS FOR CONTROL VALVES MODELS 788DVC DIGITAL

TABLE 4: AGENCY CERTIFICATIONS FOR CONTROL VALVES

Certification type		Description	Certificate
Electrical	INMETRO	Ex db IIC T6...T3 GB	NCC 23.0118X rev 0

With over 90 years of experience, Daniel is the only manufacturer that has the knowledge and experience to engineer and offer superior products that are trusted to provide the most reliable and accurate measurements in the global oil and gas industry.

Contact Us

Email: sales@Daniel.com

Phone: +1 (346) 509-3700

www.Daniel.com



Decades Proven. Field Chosen.™