

DANIEL[®] LIQUID TURBINE METER PRODUCT GUIDE

SERIES 1500



DANIEL[®]
Decades Proven. Field Chosen.[™]

SERIES 1500 LIQUID TURBINE FLOW METER

CUSTODY TRANSFER RELIABILITY

Reliable 24/7 operation combined with linear, repeatable measurement make the Daniel® Series 1500 Liquid Turbine Meter the instrument of choice for custody transfer volumetric flow measurement. Engineered for demanding crude oil and refined product applications, the durable meter now features potted electronics that endure significant vibration and shock along with rugged internals for steady, long-term performance.

The unique design of the meter's stainless steel internal assembly features a dual-hanger suspension system that supports the assembly both upstream and downstream. The system also centers and balances the rotor in the flow tube and provides for positive bearing lubrication, resulting in maximum volume throughput and minimum pressure drop. In addition, standard tungsten carbide journal bearings ensure nearly frictionless rotor movement and deliver exceptional longevity.

The meter's local mounted enclosure (LME) is configured with two pickoff coils and a standard dual-channel preamplifier that is encased in an epoxy resin (potted), enabling it to withstand vibration, shock and harsh environments. The combination of two pickoffs and the dual-channel preamplifier in each LME guarantees pulse integrity and virtually eliminates the potential for missing or double-counted pulses. For complete measurement redundancy, a second LME can be added to achieve four matched pulse outputs, enabling the meter to accommodate a wide variety of metering and proving requirements.

API COMPLIANT

The Series 1500 Liquid Turbine Flow Meter is specifically designed for pipeline operation and for use within the guidelines of the API Manual of Petroleum Measurement Standards (MPMS), Chapter 5.3 (Measurement of Liquid Hydrocarbons by Turbine Meter).

FIGURE 1: DANIEL® 1500 LIQUID TURBINE FLOW METER



TYPICAL APPLICATIONS

- Custody transfer and check metering
- Crude oil and refined product pipelines
- In-line refined product blending
- Tank farm/storage inventory control
- Tank ship and rail car loading and off-loading
- Floating storage and off-loading (FSO)
- Floating production, storage and off-loading (FPSO)

FEATURES AND BENEFITS

- Pulse output linear with flow rate and 10:1 rangeability (turndown) ensure custody transfer accuracy
- High-frequency pulse resolution enables measurement of minute increments of flow rate for greater accountability
- Stainless steel internal assembly ensures maximum volume throughput and minimum pressure drop
- Tungsten carbide bearings guarantee durability and longevity with minimal maintenance required
- Local mounted enclosure (LME) configured with two pickoffs and a standard dual-channel preamplifier for total pulse integrity
- Dual LME configuration offers four pulse outputs in two pairs that are each 90° electrically out-of-phase for complete redundancy and reliability
- Electronics designed for easy access to pickoffs and preamplifier to simplify service
- LME housing is explosion and weather proof for safe operation within refineries and harsh environments

A RANGE OF AVAILABLE OPTIONS

- DN25 to DN600 (1 to 24-in) line sizes
- Stainless or carbon steel meter body
- Rimmed, bladed or light product rotors
- Bi-directional flow
- NACE MR0175-compliant construction
- Single or dual LME
- Daniel® XRT Flow/Rate Totalizer with backlit local display

STANDARD SPECIFICATIONS

The standard performance parameters and materials of construction are noted. Additional product and material offerings may be available depending on the application. Please consult with a Daniel® product specialist to confirm.

PROCESS PARAMETERS

TABLE 1: PROCESS TEMPERATURE RANGE

	Carbon steel	304/316 Stainless
Standard ⁽¹⁾	-20°F to +140°F (-29°C to +60°C)	-40°F to +140°F (-40°C to +60°C)
High temperature	-20°F to +400°F (-29°C to +204°C)	-40°F to +400°F (-40°C to +204°C)

(1) Remote mounted enclosure (RME) and high temperature options required for ambient temperatures >+60°C (+140°F) or for process temperatures \geq +85°C (+185°F).

TABLE 2: LINEARITY

Size		Standard linearity	Premium linearity	Repeatability
DN	Inches			
25 to 65	1 to 2.5	$\pm 0.25\%$	$\pm 0.15\%$	$\pm 0.02\%$
80 to 600	3 to 24	$\pm 0.15\%$	$\pm 0.1\%$ (5:1 Turndown)	$\pm 0.02\%$
			$\pm 0.07\%$ (5:1 Turndown)	$\pm 0.02\%$

SAFETY AND COMPLIANCE

Electrical

- UL / cUL Class I, Division 1, Groups B, C and D
- ATEX: Ex d IIC T6 Gb
- IECEx: Ex d IIC T6 Gb
- INMETRO: BR- Ex d IIC T6 Gb

Environmental

- NEMA 4X (IEC IP66)

Metrology

- NMI TC7573, Revision 3

Operating Pressure

Refer to ASME/ANSI B16 standards, and your meter's material of construction, to determine the maximum operating temperature and pressure. Emerson will provide materials of construction and ASME/ANSI ratings information on each product nameplate.

STANDARD FLOW RANGES

For DN25 to DN200 (1-in to 8-in) meters, Specific Gravity (SG) is 0.78 and Kin. Visc. (cSt) is 2.1. For DN250 to DN600 (10-in to 24-in) meters, SG is 1.0 and Kin. Visc. (cSt) is 1.0.

TABLE 3: LINEAR FLOW RANGE⁽¹⁾

Nominal Size		BBL/HR			M ³ /HR			USGPM			
DN	Inches	Standard Flow Range		Extended Max Flow Rate ⁽²⁾	Standard Flow Range		Extended Max Flow Rate ⁽²⁾	Extended Min Flow Rate Linearity 0.75% (1"-2.5") 0.50% (3"-24")	Standard Flow Range		Extended Max Flow Rate
		Min	Max		Min	Max			Min	Max	
25	1	10	100	115	1.6	16	18	5.6	7	70	81
40	1.5	21	214	246	3.4	34	39	12	15	150	173
50	2	43	429	493	6.8	68	78	24	30	300	345
65	2.5	57	571	657	9.1	91	105	32	40	400	460
80	3	100	1,000	1,150	15.9	159	183	56	70	700	805
100	4	185	1,850	2,128	29.4	294	338	104	130	1,295	1,489
150	6	420	4,000	4,380	66.8	668	768	235	294	2,940	3,381
200	8	850	8,500	9,775	135	1,351	1,554	476	595	5,950	6,843
250	10	1,200	12,000	13,800	191	1,908	2,194	672	840	8,400	9,660
300	12	1,800	18,000	20,700	286	2,862	3,291	1,008	1,260	12,600	14,490
400	16	2,800	28,000	32,200	445	4,452	5,120	1,568	1,960	19,600	22,540
450	18	4,000	40,000	46,000	636	6,359	7,313	2,240	2,800	28,000	32,200
500	20	4,800	48,000	55,200	763	7,631	8,776	2,688	3,360	33,600	38,640
600	24	6,000	60,000	69,000	954	9,539	10,970	3,360	4,200	42,000	48,300

(1) Bi-directional meters have a standard linear flow range as stated above. The minimum flow rate in the reverse direction is 20% of its maximum extended flow rate.

(2) Extended flow rate with 20% duty cycle not to exceed 2 hours per day.

TABLE 4: NOMINAL K-FACTOR⁽¹⁾

Nominal Size		Pulses/BBL		Pulses/M ³		Pulses/US Gal	
DN	Inches	Blade	Rim	Blade	Rim	Blade	Rim
25	1	21,000	N/A	132,086	N/A	500	N/A
40	1.5	9,660	N/A	60,760	N/A	230	N/A
50	2	5,460	N/A	34,342	N/A	130	N/A
65	2.5	2,730	N/A	17,171	N/A	65	N/A
80	3	2,100	4,620	13,209	29,059	50	110
100	4	1,000	2,940	6,287	18,462	24	70
150	6	245	1,050	1,532	6,604	5.8	25
200	8	N/A	550	N/A	3,461	N/A	13
250	10	N/A	250	N/A	1,585	N/A	6.0
300	12	N/A	200	N/A	1,268	N/A	4.8
400	16	N/A	100	N/A	634	N/A	2.4
450	18	N/A	100	N/A	634	N/A	2.4
500	20	N/A	100	N/A	634	N/A	2.4
600	24	N/A	100	N/A	634	N/A	2.4

(1) K-Factors for individual rotors vary. An acceptable rotor can be nominal ±15%.

FLOW RANGE ADJUSTMENT

The tables below represent the effect of specific gravity on the linear flow range.

TABLE 5: SPECIFIC GRAVITY = 0.7 TO 1 (BLADE AND RIM TYPE INTERNALS)

Nominal Size		Minimum Linear Flow Rate			Maximum Linear Flow Rate		
DN	Inches	BBL/HR	M ³ /HR	USGPM	BBL/HR	M ³ /HR	USGPM
25	1	10	1.6	7	100	15.9	70
40	1.5	21	3.4	15	214	34.1	150
50	2	43	6.8	30	429	68.1	300
65	2.5	57	9.1	40	571	90.9	400
80	3	100	15.9	70	1,000	159	700
100	4	186	29.5	130	1,850	294	1,295
150	6	420	66.8	294	4,200	668	2,940

TABLE 6: SPECIFIC GRAVITY = 0.6 (BLADE TYPE INTERNALS ONLY)

Nominal Size		Minimum Linear Flow Rate			Maximum Linear Flow Rate		
DN	Inches	BBL/HR	M ³ /HR	USGPM	BBL/HR	M ³ /HR	USGPM
25	1	17	2.7	12	116	18.4	81
40	1.5	36	5.7	25	247	39.3	173
50	2	71	11.4	50	493	78.4	345
65	2.5	96	15.2	67	657	105	460
80	3	167	26.6	117	1,150	183	805
100	4	309	49.1	216	2,129	338	1,490
150	6	701	112	491	4,830	768	3,381

TABLE 7: SPECIFIC GRAVITY = 0.5 (BLADE TYPE INTERNALS ONLY)

Nominal Size		Minimum Linear Flow Rate			Maximum Linear Flow Rate		
DN	Inches	BBL/HR	M ³ /HR	USGPM	BBL/HR	M ³ /HR	USGPM
25	1	23	3.6	16	116	18.4	81
40	1.5	50	7.9	35	247	39.1	172
50	2	101	16.1	71	493	78.4	345
65	2.5	134	21.3	94	657	105	460
80	3	236	37.5	165	1,150	183	805
100	4	436	69.3	305	2,129	338	1,490
150	6	989	157	692	4,830	768	3,381

TABLE 8: SPECIFIC GRAVITY = 0.4 (BLADE TYPE INTERNALS ONLY)

Nominal Size		Minimum Linear Flow Rate			Maximum Linear Flow Rate		
DN	Inches	BBL/HR	M ³ /HR	USGPM	BBL/HR	M ³ /HR	USGPM
25	1	23	4.5	20	116	18.4	81
40	1.5	60	9.5	42	246	39.1	172
50	2	120	19.1	84	493	78.4	345
65	2.5	160	25.4	112	657	105	460
80	3	280	44.5	196	1,150	183	805
100	4	517	82.2	362	2,129	338	1,490
150	6	1,173	187	821	4,830	768	3,381

TABLE 9: SPECIFIC GRAVITY = 0.3 (BLADE TYPE INTERNALS ONLY)

Nominal Size		Minimum Linear Flow Rate			Maximum Linear Flow Rate		
DN	Inches	BBL/HR	M ³ /HR	USGPM	BBL/HR	M ³ /HR	USGPM
25	1	33	5.2	23	116	18.4	81
40	1.5	71	11.4	50	246	39.1	172
50	2	141	22.5	99	493	78.4	345
65	2.5	190	30.2	133	657	105	460
80	3	331	52.7	232	1,150	183	805
100	4	613	97.4	429	2,129	338	1,490
150	6	1,393	221	975	4,830	768	3,381

PRESSURE DROP

Figure 2 below represents pressure drop characteristics on water for the Series 1500 Liquid Turbine Meter by line size.

FIGURE 2: PRESSURE DROP CHART

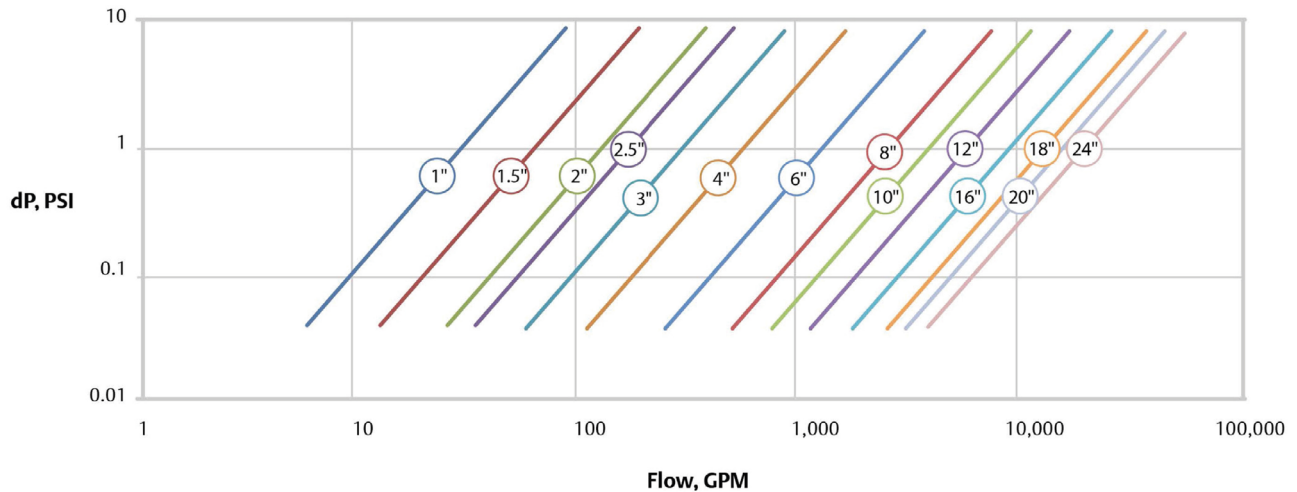

ELECTRICAL FEATURES

PREAMPLIFIERS

The local mounted enclosure (LME) on the Daniel® Series 1500 Liquid Turbine Meter contains a standard dual-channel preamplifier and two variable reluctance pickoff coils. These coils have the sensitivity to provide accurate detection of rotor travel and have output with electrical characteristics of high impedance and low voltage. Noise-free transmission of flow signals requires low impedance and high voltage. This is the function of the signal preamplifier. Turbine meter preamplifiers, located within 16.4 feet (5 meters) of the pickoff coil, shape and condition the signal, rendering it suitable for transmission over distances of up to 3,000 feet (914 meters).

AVAILABLE MODELS

Standard

- The Model 2818 Dual Channel Preamplifier is the standard Daniel® offering for most liquid turbine meter applications. The signals from two inductive pickoff coils, positioned 90° electrically out of phase, are strengthened and conditioned by a single preamplifier. Fully potted in POM (Polyoxymethylene), the Model 2818 preamplifier has three possible outputs: powered pulse, variable voltage and open collector.
- The Model 2415 intrinsically safe Preamplifier is for hazardous area use (Zone 0).
- The Model 1815B Zero Crossing Preamplifier produces an output pulse with each zero crossing of the input signal. It ensures high resolution, producing twice the pulses from a single pickoff.
- The Model 1817X2 Bi-Directional Preamplifier is used on liquid turbine meters when the requirement is to accumulate flow in both forward and reverse directions.

Optional

- Additional preamplifier models are available. Consult with a Daniel® product specialist to confirm the best model for the application.

ELECTRICAL PERFORMANCE

Pickoff specifications

- Type: 2-wire reluctance
- Resistance: 600 to 900 ohms
- Inductance: 250mH max
- Output: Sinusoidal 40mV p-p minimum @minimum flow with preamplifier load
- Optional: 2 pickoff coils (single or dual LME) or 4 pickoff coils (dual LME required)

STANDARD PREAMPLIFIERS

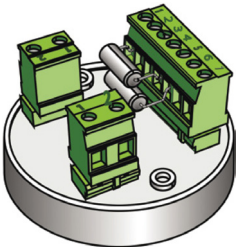
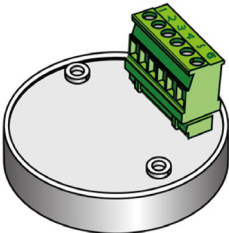
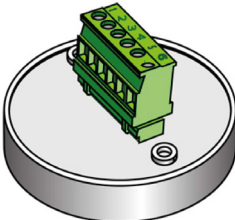
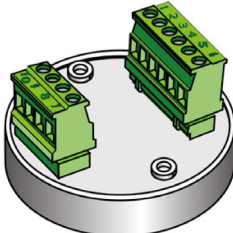
				
TYPE	Dual channel	Intrinsically Safe	Zero Crossing	Bi-Directional
MODEL #	2818	2415	1815B	1817X2
Daniel® Part #	1-504-05-550	1-504-05-449	1-504-05-510	1-504-05-442
INPUTS				
# of Inputs (Pickoffs):	1 or 2	1	1	2
Supply Voltage:	10 to 30 VDC	11.5 to 25 VDC	12 to 30 VDC	11.5 to 36 VDC
Sensor Type:	Reluctance	Reluctance	Reluctance	Reluctance
Signal:	Sine Wave	Sine Wave	Sine Wave	Sine Wave
Current:	10 to 30 VDC @ 40 mA p-p	< 12 mA	10 mA @ 15V	11.5 to 36 VDC < 30 mA
Preamplifier Sensitivity:	40 mVpp	10 Hz to 1 KHz (60mV p-p) 10 Hz to 3 KHz (60mV p-p) 10 Hz to 1 KHz (60mV p-p)	40 mV peak-to-peak	40 mV peak-to-peak
Frequency Response:	0 to 5 kHz	5 Hz to 5 kHz	0 to 5 kHz	5 Hz to 5 kHz
OUTPUTS (POWERED PULSE)				
Type:	Square Wave	Square Wave	Square Wave	Square Wave
Frequency Range:	≤ 0 to 5 kHz	≤ 5 Hz to 5 kHz	≤ 5 kHz	≤ 5 Hz to 5 kHz
Amplitude:	0 to 5 V	0 to 5 V	0 to 12 V	0 to Vs
Impedance:	1000 Ohm, 20 mA max	20000 Ohm	300 Ohm	O.C.
CONSTRUCTION				
Materials	POM ⁽¹⁾ Housing Solid Epoxy Encapsulation	POM ⁽¹⁾ Housing Solid Epoxy Encapsulation	POM ⁽¹⁾ Housing Solid Epoxy Encapsulation	POM ⁽¹⁾ Housing Solid Epoxy Encapsulation
TEMPERATURE RANGE				
F° (C°)	-40°F to +185°F (-40°C to +85°C)	-40°F to +185°F (-40°C to +85°C)	-40°F to +185°F (-40°C to +85°C)	-40°F to +185°F (-40°C to +85°C)
CUSTOMER CONNECTION				
Terminal Block 1 (TB1):	(1) +10 to 30 VDC (2) Common (3) Common (4) Channel A Output (5) Channel B Output (6) TTL Out A (7) TTL Out B	(1) 11.5 to 25 VDC (2) Common (3) Signal Out (Half-Freq) (4) Signal Out	(1) 12 to 30 VDC (2) Common (3) Output Signal (x1) (4) Output Signal (x2)	(1) 11.5 to 36 VDC (2) Common (3) Direction (4) Channel A Out (5) Channel B Out (6) Prover Out (x2)
PICKOFFS				
Channel A (TB2):	(1) White (2) Red	(5) White (6) Red	(5) White (6) Red	(1) White (2) Red
Channel B (TB3):	(1) White (2) Red			(1) White (2) Red

(1) POM - Polyoxymethylene - An engineered thermoplastic.

MATERIALS OF CONSTRUCTION

STANDARD MATERIALS

TABLE 10: METER WITH BLADED ROTOR (DN25 TO DN150 / 1-IN TO 6-IN)

Meter body and flanges	Carbon steel	304 Stainless steel (304SS)	316 Stainless steel (316SS)
Local Mounted Electronics (LME)	316SS	316SS	316SS
Blades:			
DN25 (1-in)	430SS / 316SS	430SS / 304SS	NICKEL-200 / 316SS
DN40 to DN150 (1-in to 6-in)	430SS / NICKEL-200 ⁽¹⁾	430SS	NICKEL-200 ⁽¹⁾
Rotor Hub:			
DN25 to DN150 (1-in to 6-in)	430SS / 316SS	430SS	316SS
Shaft:			
DN25 to DN65 (1-in to 2.5-in)	316SS	316SS	316SS
DN80 to DN150 (3-in to 6-in)	17-4 PH SS HT ⁽²⁾	17-4 PH SS HT ⁽²⁾	17-4 PH SS HT ⁽²⁾
Tolerance Rings (DN65 to DN600 / 2.5-in to 24-in)	Nickel Alloy	Nickel Alloy	Nickel Alloy
Bearing Set	Tungsten Carbide	Tungsten Carbide	Tungsten Carbide
Suspension	304SS / 316SS	304SS	316SS
Cones	304SS / 316SS	304SS	316SS

(1) Rim type rotor not recommended, use blade type rotor only.

(2) For full NACE MR0175:2002 compliancy, material will change to 316SS with hard chrome or optional full NACE MR175/ISO151: 2003

TABLE 11: METER WITH RIMMED ROTOR (DN80 TO DN600 / 3-IN TO 24-IN)

Meter body and flanges	Carbon steel	304 Stainless steel (304SS)	316 Stainless steel (316SS)
Local Mounted Electronics (LME)	316SS	316SS	316SS
Blades	304SS / 316SS	304SS	316SS
Rotor Hub	430SS / 316SS	430SS	316SS
Rotor Rim:			
DN80 to DN100 (3-in to 4-in)	316SS	316SS	316SS
DN150 to DN600 (6-in to 24-in)	304SS / 316SS	304SS	304SS
Shaft	17-4 PH SS HT ⁽¹⁾	17-4 PH SS HT ⁽¹⁾	17-4 PH SS HT ⁽¹⁾
Tolerance Rings	Nickel Alloy	Nickel Alloy	Nickel Alloy
Bearing Set	Tungsten Carbide	Tungsten Carbide	Tungsten Carbide
Suspension	304SS / 316SS	304SS	316SS
Deflector Ring	304SS / 316SS	304SS	316SS
Rim Buttons	Mu-Metal	Mu-Metal	Mu-Metal
Cones	304SS / 316SS	304SS	316SS

(1) For full NACE MR0175:2002 compliancy, material will change to 316SS with hard chrome or optional full NACE MR175/ISO151: 2003.

TABLE 12: METER WITH LIGHTWEIGHT ROTOR (DN80 TO DN300 / 3-IN TO 12-IN)

Meter body and flanges	Carbon steel	304 Stainless steel (304SS)	316 Stainless steel (316SS)
Local Mounted Electronics (LME)	316SS	316SS	316SS
Blades:			
DN80 to DN100 (3-in to 4-in) Blade Type	430SS	430SS	430SS
DN150 to DN300 (6-in to 12-in) Rim Type	304SS	304SS	304SS
Rotor Hub:			
DN80 (3-in)	430SS	430SS	430SS
DN100 to DN300 (4-in to 12-in)	6061-T6 ALUM	6061-T6 ALUM	6061-T6 ALUM
Shroud (DN150 to DN300 / 6-in to 12-in)	430SS	430SS	430SS
Shaft	17-4 PH SS HT ⁽¹⁾	17-4 PH SS HT ⁽¹⁾	17-4 PH SS HT ⁽¹⁾
Tolerance Rings	Nickel Alloy	Nickel Alloy	Nickel Alloy
Bearing Set	Tungsten Carbide	Tungsten Carbide	Tungsten Carbide
Suspension	304SS / 316SS	304SS	304SS
Deflector Ring	304SS / 316SS	304SS	316SS
Cones	304SS / 316SS	304SS	304SS

(1) For full NACE MR0175:2002 compliancy, material will change to 316SS with hard chrome or optional full NACE MR175/ISO151: 2003.

NOTE

Teflon coated rotor available for rim and blade type.

NACE MR0175 2003 COMPLIANT MATERIALS

TABLE 13: METER WITH BLADED ROTOR (DN25 TO DN150 / 1-IN TO 6-IN)

Meter body and flanges	Carbon steel	304 Stainless steel (304SS)	316 Stainless steel (316SS)
Local Mounted Electronics (LME)	316SS	316SS	316SS
Blades:			
DN25 (1-in)	430SS / 304SS	430SS / 304SS	430SS / 304SS
DN40 to DN150 (1-in to 6-in)	430SS	430SS	430SS
Rotor Hub	430SS	430SS	316SS
Shaft:			
DN25 to DN65 (1-in to 2.5-in)	316SS	430SS	430SS
DN80 to DN150 (3-in to 6-in)	316SS with Hard Chrome ⁽¹⁾	316SS with Hard Chrome ⁽¹⁾	316SS with Hard Chrome ⁽¹⁾
Tolerance Rings (DN65 to 600 / 2.5-in to 24-in)	Nickel Alloy	Nickel Alloy	Nickel Alloy
Bearing Set	Tungsten Carbide	Tungsten Carbide	Tungsten Carbide
Suspension	304SS	304SS	316SS
Cones	304SS	304SS	316SS

(1) For full NACE MR0175:2002 compliance, material will change to 316SS with hard chrome or optional full NACE MR175/ISO151: 2003.

TABLE 14: METER WITH RIMMED ROTOR (DN80 TO DN600 / 3-IN TO 24-IN)

Meter body and flanges	Carbon steel	304 Stainless steel (304SS)	316 Stainless steel (316SS)
Local Mounted Electronics (LME)	316SS	316SS	316SS
Blades	304SS	304SS	316SS
DN40 to DN150 (1-in to 6-in)	430SS	430SS	316SS
Rotor Rim:			
DN80 to DN100 (3-in to 4-in)	316SS	316SS	316SS
DN150 to DN600 (6-in to 24-in)	304SS	304SS	316SS
Shaft	316SS with Hard Chrome ⁽¹⁾	316SS with Hard Chrome ⁽¹⁾	316SS with Hard Chrome ⁽¹⁾
Tolerance Rings	Nickel Alloy	Nickel Alloy	Nickel Alloy
Bearing Set	Tungsten Carbide	Tungsten Carbide	Tungsten Carbide
Suspension	304SS	304SS	316SS
Deflector Ring	304SS	304SS	316SS
Rim Buttons	Mu-Metal	Mu-Metal	Mu-Metal
Cones	304SS	304SS	316SS

(1) For full NACE MR0175:2002 compliancy, material will change to 316SS with hard chrome or optional full NACE MR175/ISO151: 2003.

NOTE

Teflon coated rotor available for rim and blade type.

PRODUCT DIAGRAMS

LOCAL MOUNTED ENCLOSURE (LME)

Configuration shown temperature up to +140° F (+60° C).

FIGURE 3: LOCAL MOUNTED ENCLOSURE EXPLODED VIEW

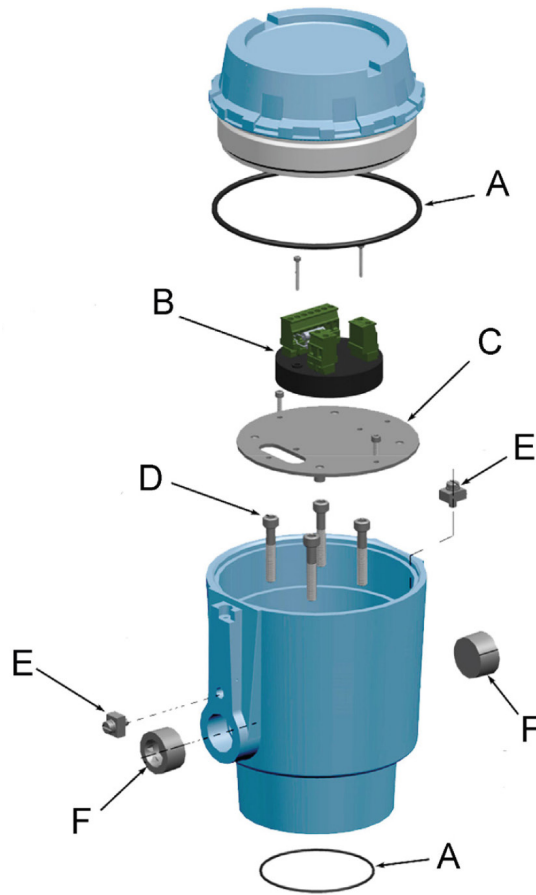

- A. O-ring
- B. Dual-Channel Preamplifier
- C. Mounting bracket
- D. Socket head screws
- E. Grounding cap
- F. Plug pipe hex socket

RIM TYPE ROTOR

Available in DN80 to DN600 (3-in to 24-in).

FIGURE 4: RIM TYPE ROTOR EXPLODED VIEW

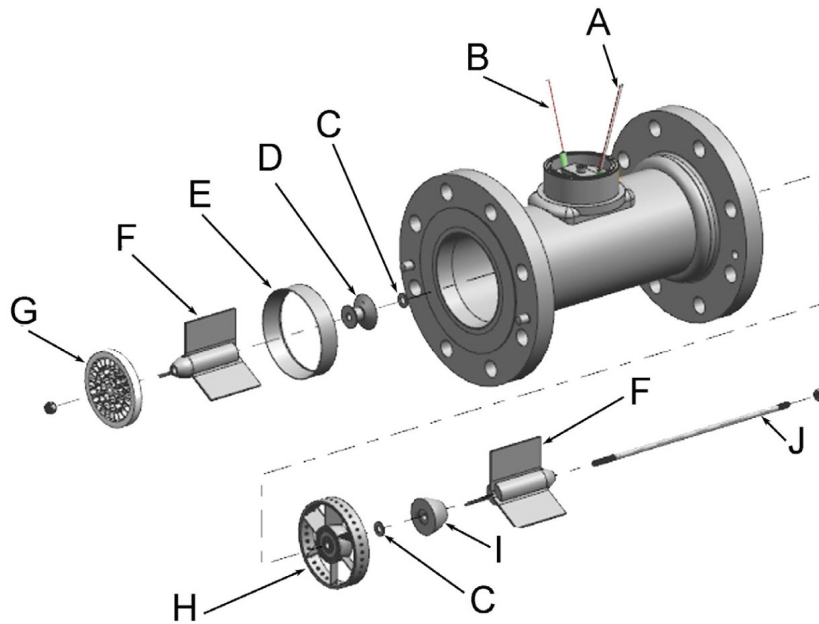

- A. O-ring
- B. Pick B
- C. Thrust washer
- D. Upstream cone
- E. Deflector ring
- F. Hanger blades
- G. Flow conditioning plate (Optional DN80 - DN 150 only)
- H. Rim type rotor assembly
- I. Downstream cone
- J. Shaft

BLADE TYPE ROTOR

Available in DN25 to DN150 (1-in to 6-in).

FIGURE 5: BLADE TYPE ROTOR EXPLODED VIEW

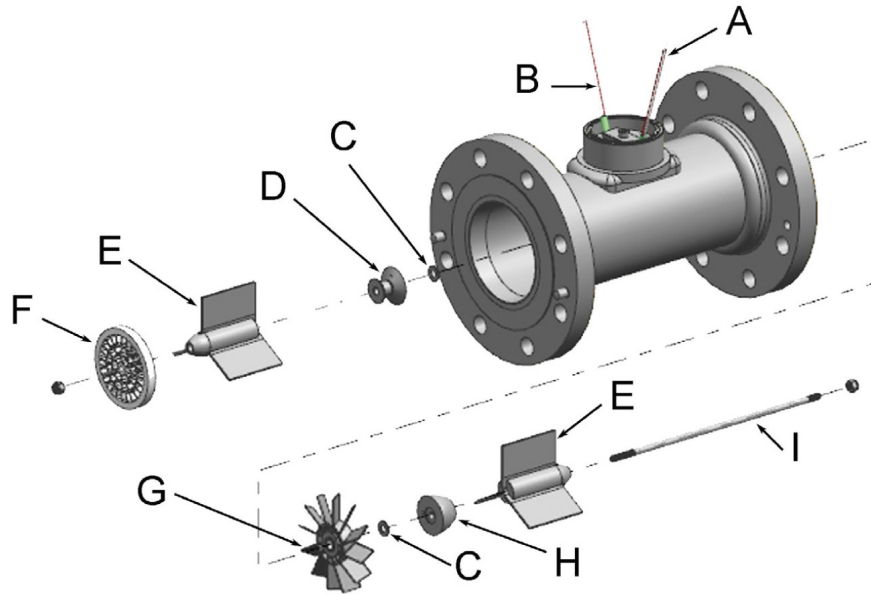

- A. Pickoff A
- B. Pick B
- C. Thrust washer
- D. Upstream cone
- E. Hanger blade
- F. Flow conditioning plate (Optional DN80 - DN150 only)
- G. Blade rotor assembly
- H. Downstream cone
- I. Shaft

WEIGHTS AND DIMENSIONS

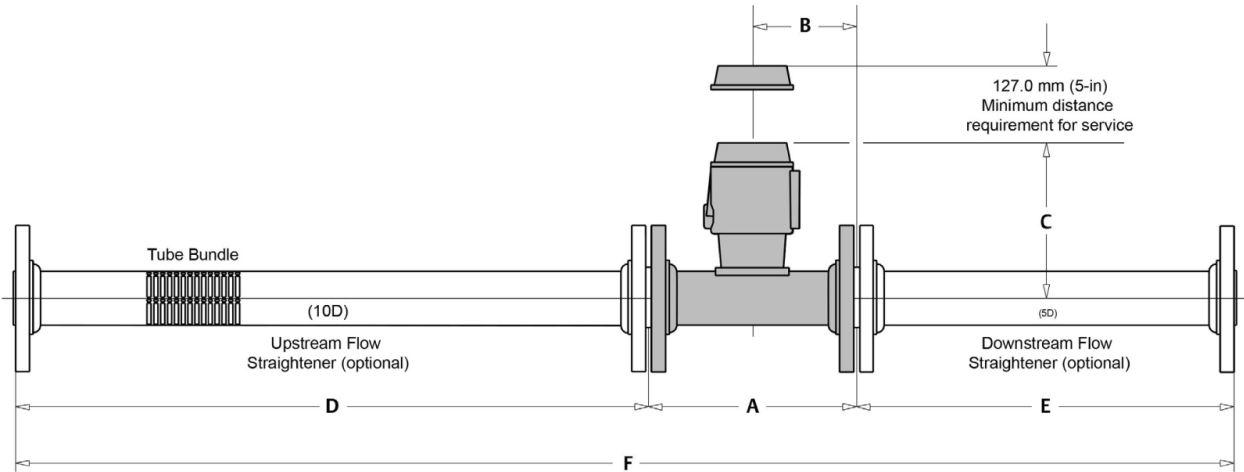

TABLE 15: DIMENSIONAL DATA FOR DANIEL® SERIES 1500 LIQUID TURBINE FLOW METER AND FLOW STRAIGHTENING SECTIONS ⁽¹⁾

Sizes		A		B		C		D		E		F	
DN	Inches	mm	Inches	mm	Inches	mm	Inches	mm	Inches	mm	Inches	mm	Inches
25 ⁽²⁾	1 ⁽²⁾	203	8	102	4	259	10	508	20	127	5	841	33
40 ⁽²⁾	1.5 ⁽²⁾	229	9	114	4.5	269	11	762	30	191	8	1,184	47
50	2	229	9	114	4.5	269	11	508	20	254	10	994	39
65	2.5	254	10	127	5	279	11	635	25	318	13	1,210	48
80	3	254	10	127	5	279	11	762	30	381	15	1,400	55
100	4	305	12	152	6	297	12	1,026	40	508	20	1,832	72
150	6	356	14	178	7	325	13	1,524	60	762	30	2,645	104
200	8	406	16	203	8	351	14	2,032	80	1,016	40	3,458	136
250	10	508	20	254	10	376	15	2,540	100	1,270	50	4,321	170
300	12	610	24	305	12	401	16	3,048	120	1,524	60	5,185	204
400	16	813	32	406	16	445	18	4,064	160	2,032	80	6,912	272
450	18	914	36	457	18	470	19	4,572	180	2,286	90	7,776	306
500	20	1,016	40	508	20	495	20	5,080	200	2,540	100	8,639	340
600	24	1,219	48	610	24	546	22	6,096	240	3,048	120	10,366	408

(1) Dimension A applies to ANSI 150 to ANSI 900 liquid turbine meters. For ANSI 1500 and ANSI 2500 liquid turbine meters, consult factory.

(2) DN25 and DN40 (1-in and 1.5-in) size meters do not use straightening vanes for flow conditioning. These meter sizes employ a 20D upstream section.

TABLE 16: APPROXIMATE SHIPPING WEIGHT WITH SINGLE ALUMINUM LME ⁽¹⁾

Sizes		ANSI 150 RF		ANSI 300 RF		ANSI 600 RF & RTJ		ANSI 900 RF & RTJ		ANSI 1500 RF & RTJ		ANSI 2500 RF & RTJ	
DN	Inches	kg	lbs	kg	lbs	kg	lbs	kg	lbs	kg	lbs	kg	lbs
25	1	9.6	21	10.6	23	11.6	26	18.6	41	18.6	41	CF	CF
40	1.5	12.6	28	14.1	31	15.6	34	25.9	57	25.9	57	CF	CF
50	2	13.6	30	14.6	32	16.6	37	35.4	78	35.4	78	CF	CF
65	2.5	17.6	39	20.6	45	22.6	50	45.3	100	45.3	100	CF	CF
80	3	19.1	42	23.6	52	25.6	56	53.6	118	65.7	145	CF	CF
100	4	25.6	56	35.6	78	44.1	97	66.6	147	96.00	211	CF	CF
150	6	40.6	89	55.6	122	81.6	180	126	276	176	386	CF	CF
200	8	59.6	131	86.6	191	130	285	198	435	CF	CF	N/A	N/A
250	10	98.6	217	132	290	213	468	251	551	CF	CF	N/A	N/A
300	12	151	331	202	444	272	598	304	668	CF	CF	N/A	N/A
400	16	335	736	385	846	575	1,264	412	905	CF	CF	N/A	N/A
450	18	502	1,104	530	1,165	756	1,662	CF	CF	CF	CF	N/A	N/A
500	20	CF	CF	CF	CF	CF	CF	CF	CF	CF	CF	N/A	N/A
600	24	CF	CF	CF	CF	CF	CF	CF	CF	CF	CF	N/A	N/A

(1) For single stainless steel LME, add 3.75 kg (8.3 lb)

CF = consult factory

ORDERING INFORMATION

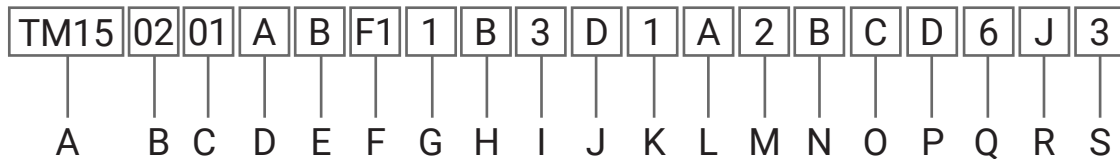

- A. Device
- B. Line size / Standard flow range
- C. Pressure rating
- D. Flange type
- E. NACE
- F. Body and flange material
- G. Meter internal materials
- H. Enclosure material
- I. Enclosure options
- J. Preamplifier options (per enclosure)
- K. Flow direction
- L. Rotor type
- M. Flow conditioning
- N. Display
- O. Display mounting
- P. Meter linearity

- Q. Metrology approval
- R. Agency approvals
- S. Tagging format (nameplate)

This is for informational purposes only. Not every option is listed and some options are contingent on others. Please consult factory for assistance designing your optimal meter.

DEVICE

Code	Device
TM15	Series 1500 Turbine Flow Meter

LINE SIZE/STANDARD FLOW RANGE

Code	Case option
01	1-in (DN25) / 7-70 GPM, 10-100 BHP, 1.6-16 M ³ /H
15	1.5-in (DN40) / 15-150 GPM, 21-214 BHP, 3.4-34 M ³ /H
02	2-in (DN50) / 30-300 GPM, 43-429 BHP, 6.8-68 M ³ /H
25	2.5-in (DN65) / 40-400GPM, 57-571 BHP, 9.1-91 M ³ /H
03	3-in (DN80) / 70-700 GPM, 100-1000 BHP, 15.9-159 M ³ /H
04	4-in (DN100) / 130-1295 GPM, 185-1850 BHP, 29.4-294 M ³ /H
06	6-in (DN150) / 294-2940 GPM, 420-4200 BHP, 66.8-668 M ³ /H
08	8-in (DN200) / 595-5950 GPM, 850-8500 BHP, 135-1,351 M ³ /H
10	10-in (DN250) / 840-8400 GPM, 1200-12000 BHP, 191-1,908 M ³ /H
12	12-in (DN300) / 1260-12600 GPM, 1800-18000 BHP, 286-2,862 M ³ /H
16	16-in (DN400) / 1960-19600 GPM, 2800-28000 BHP, 445-4,452 M ³ /H
18	18-in (DN450) / 2800-28000 GPM, 4000-40000 BHP, 636-6,359 M ³ /H
20	20-in (DN500) / 3,360-33,600 GPM, 4,800-48,000 BHP, 763-7,631 M ³ /H
24	24-in (DN600) / 4,200-42,000 GPM, 6,000-60,000 BHP, 954-9,539 M ³ /H

PRESSURE RATING

Code	Description
01	ANSI 150 / 285 PSI MWP, RF Flange / 1-in (DN25) to 24-in (DN600)
03	ANSI 300 / 740 PSI MWP, RF Flange / 1-in (DN25) to 24-in (DN600)
05	ANSI 600 / 1,480 PSI MWP, RF Flange / 1-in (DN25) to 24-in (DN600)
06	ANSI 900 / 2,220 PSI MWP, RF Flange / 1-in (DN25) to 24-in (DN600)
07	ANSI 1500 / 3,705 PSI MWP, RF Flange / 1-in (DN25) to 2.5-in (DN65)
08	ANSI 2500 / 6,170 PSI MWP, RTJ Flange / 1-in (DN25) to 2.5-in (DN65)
16	PN 16 / 16 BAR MWP, RF Flange / DN25 (1-in) to DN600 (24-in)
25	PN 25 / 25 BAR MWP / DN25 (1-in) to DN600 (24-in)
40	PN 40 / 40 BAR MWP / DN25 (1-in) to DN600 (24-in)
63	PN 63 / 63 BAR MWP / DN25 (1-in) to DN600 (24-in)
10	PN 100 / 100 BAR MWP / DN25 (1-in) to DN600 (24-in)

FLANGE TYPE

Code	Description
A	RF Slip On (125-250 AARH) ANSI 150-900: 1-in (DN25) to 24-in (DN600). ANSI 1500: 1-in (DN25) to 2.5-in (DN65)
B	RF Slip On ANSI 600-900: 1-in to 24-in. ANSI 1500-2500: 1-in (DN25) to 2.5-in (DN65)
C	RTJ Weld Neck ANSI 1500: 3-in (DN80) to 24-in (DN600). Not available for ANSI 150-900

NACE

Code	Case option
A	No
B	Yes

BODY AND FLANGE MATERIAL

Code	Description
F1	Carbon steel
F2	304 Stainless steel
F3	316 Stainless steel

METER INTERNAL MATERIALS

Code	Case option
1	304 Stainless steel
2	316 Stainless steel

ENCLOSURE MATERIAL

Code	Case option
B	316 Stainless steel

ENCLOSURE OPTIONS

Code	Description
1	1 LME (2 Pickoffs), Std Temp (-40°C to 60°C)
2	2 LME (4 Pickoffs), Std Temp (-40°C to 60°C)
3	1 LME (2 HI-Temp Pickoffs) w/2 Terminal Blocks, 1 RME, HI-Temp (-40°C to 204°C)
4	2 LME (4 HI-Temp Pickoffs) ea w/2 Terminal Blocks, 1 RME, HI-Temp (-40°C to 204°C)

PREAMPLIFIER OPTIONS (PER EXCLOSURE)

Code	Case option
A	None
B	1 Model 2818 (Dual Channel)
C	2 Model 2818 (Dual Channel)
D	1 Model 1815B (Zero Crossing)
E	2 Model 1815B (Zero Crossing)
F	1 Model 2415 (Intrinsically Safe)
G	2 Model 2415 (Intrinsically Safe)
H	1 Model 1817X2 (Bi-Directional)
I	2 Model 1817X2 (Bi-Directional)

FLOW DIRECTION

Code	Description
1	Horizontal Uni-Directional
2	Horizontal Bi-Directional
3	Vertical Uni-Directional (Upward Flow Only)

ROTOR TYPE

Code	Case option
A	Blade-Type Rotor
B	Blade-Type Rotor PTFE Coated
C	Rim-Type Rotor
D	Rim-Type Rotor PTFE Coated
E	Lite Product Rotor15
F	Lite Product Rotor PTFE Coated15

FLOW CONDITIONING

Code	Case option
1	No Flow Conditioning Plate
2	Aluminum Flow Conditioning Plate

DISPLAY

Code	Case option
A	No
B	Electronic Display (4-20 Loop)
C	Electronic Display (MODBUS - 24vDC)
D	Electronic Display (4-20 Loop) 316L SS Housing
E	Electronic Display (MODBUS - 24vDC) 316L SS Housing
F	Electronic Display (4-20mA - HART) 316L SS Housing

DISPLAY MOUNTING

Code	Case option
A	None
B	External

METER LINEARITY

Code	Description
C	Standard (+/- 0.25% 1"-2.5", +/- 0.15% 3"-24")
D	Premium (+/- 0.15% 1"-2.5", +/- 0.10% 3"-24")
E	Ultra (+/- 0.07% with 5:1 turndown 3"-24")

METROLOGY APPROVAL

Code	Approval
1	None
2	NTEP
5	OIML
6	MID/ OIML

AGENCY APPROVAL

Code	Certification
J	UL / CU
K	CE (Includes ATEX, PED or SEP and EMC)
M	INMETRO

TAGGING FORMAT (NAMEPLATE)

Code	Description
1	Inch / ANSI / US Customary
2	Inch / ANSI / Metric
3	DN / PN / US Customary
4	DN / PN / Metric

AGENCY CERTIFICATIONS FOR THE SERIES 1500 LTM

TABLE 17: AGENCY CERTIFICATIONS FOR THE SERIES 1500 LTM

Certification type		Description	Certificate
Electrical	UL and CUL	Class I, Div. 1, Groups B, C & D	E202815
	ATEX	Ex db IIB T6 Gb. EX dB IIC T6 Gb.	DEMKO 03 ATEX 130946X Rev. 10
	IECEX	Ex db IIB T6 Gb. EX db IIC T6 GB.	IECEX UL 11.0031X Rev 10
	INMETRO	Ex db IIC T6 Gb	NCC 23.0046 X rev 0
Environmental		NEMA 4x (IP66).	DEMKO 03 ATEX 130946X Rev. 10
Metrology		MID / OIML R117-1	TC7573 Rev. 6
Ambient temperature		-40 °C to 60 °C (-40 °F to 140 °F)	

With over 90 years of experience, Daniel is the only manufacturer that has the knowledge and experience to engineer and offer superior products that are trusted to provide the most reliable and accurate measurements in the global oil and gas industry.

Contact Us

Email: sales@Daniel.com
Phone: +1 (346) 509-3700

www.Daniel.com

