

DANIEL[®]
DIGITAL CONTROL VALVE
USER MANUAL

788DVC DIGITAL CONTROL VALVE
NPS 2 THROUGH 8 / CLASS 150-300

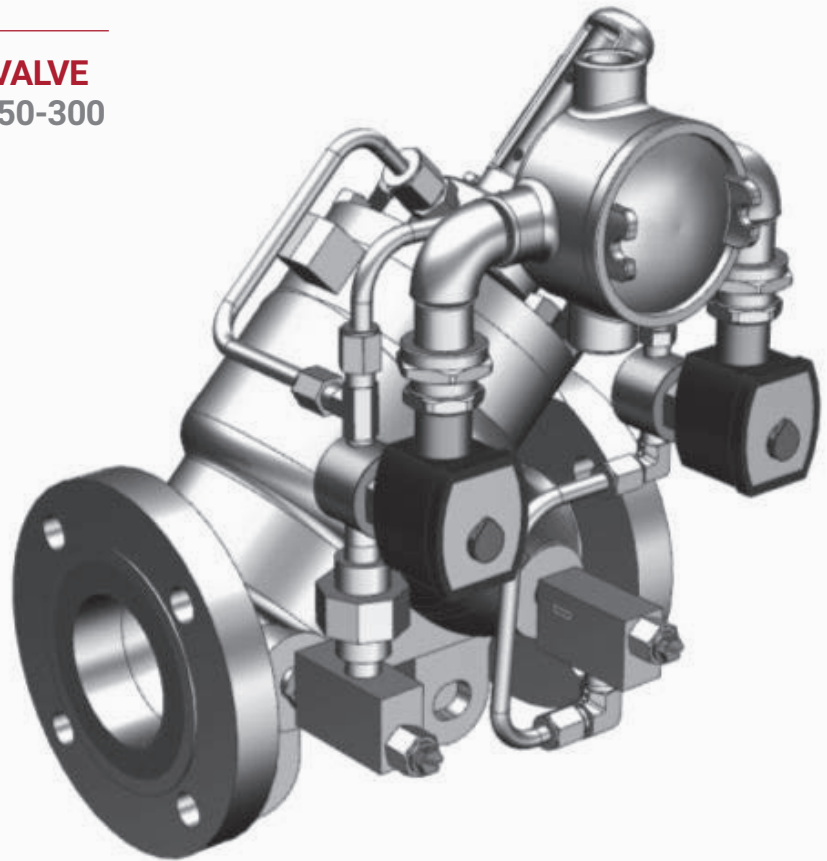

DANIEL[®]

OCTOBER 2022

Important safety instructions

Daniel Measurement and Control, Inc. (Daniel) designs, manufactures and tests products to function within specific conditions. Because these products are sophisticated technical instruments, it is important that the owner and operation personnel must strictly adhere both to the information printed on the product and to all instructions provided in this manual prior to installation, operation, and maintenance.

Daniel also urges you to integrate this manual into your training and safety program.

BE SURE ALL PERSONNEL READ AND FOLLOW THE INSTRUCTIONS IN THIS MANUAL AND ALL NOTICES AND PRODUCT WARNINGS.



WARNING

Failure to follow the installation, operation or maintenance instructions for a Daniel product could lead to serious injury or death from explosion or exposure to dangerous substances.

To reduce the risk:

- Comply with all information on the product, in this manual, and in any local and national codes that apply to this product.
- Do not allow untrained personnel to work with this product.
- Use Daniel parts and work procedures specified in this manual.

Product owners (Purchasers):

- Use the correct product for the environment and pressures present. See technical data or product specifications for limitations. If you are unsure, discuss your needs with your Daniel representative.
- Inform and train all personnel in the proper installation, operation, and maintenance of this product.
- To ensure safe and proper performance, only informed and trained personnel should install, operate, repair and maintain this product.
- Verify that this is the correct instruction manual for your Daniel product. If this is not the correct documentation, contact Daniel at 1-713-827-6314. You may also download the correct manual from: <https://www.emerson.com/en-us/automation/daniel>.
- Save this instruction manual for future reference.
- If you resell or transfer this product, it is your responsibility to forward this instruction manual along with the product to the new owner or transferee.
- ALWAYS READ AND FOLLOW THE INSTALLATION, OPERATIONS, MAINTENANCE AND TROUBLESHOOTING MANUAL(S) AND ALL PRODUCT WARNINGS AND INSTRUCTIONS.
- Do not use this equipment for any purpose other than its intended service. This may result in property damage and/or serious personal injury or death.

Product operation (Personnel):

- To prevent personal injury, personnel must follow all instructions of this manual prior to and during operation of the product.
- Follow all warnings, cautions, and notices marked on, and supplied with, this product.
- Verify that this is the correct instruction manual for your Daniel product. If this is not the correct documentation, contact Daniel at 1-713-827-6314. You may also download the correct manual from: <https://www.emerson.com/en-us/automation/daniel>.
- Read and understand all instructions and operating procedures for this product.
- If you do not understand an instruction, or do not feel comfortable following the instructions, contact your Daniel representative for clarification or assistance.
- Install this product as specified in the INSTALLATION section of this manual per applicable local and national codes.
- Follow all instructions during the installation, operation, and maintenance of this product.
- Ensure that all connections to pressure and electrical sources are secure prior to and during equipment operation.
- Use only replacement parts specified by Daniel. Unauthorized parts and procedures can affect this product's performance, safety, and invalidate the warranty. "Look-a-like" substitutions may result in deadly fire, explosion, release of toxic substances or improper operation.
- Save this instruction manual for future reference.

Notice

THE CONTENTS OF THIS PUBLICATION ARE PRESENTED FOR INFORMATIONAL PURPOSES ONLY, AND WHILE EVERY EFFORT HAS BEEN MADE TO ENSURE THEIR ACCURACY, THEY ARE NOT TO BE CONSTRUED AS WARRANTIES OR GUARANTEES, EXPRESSED OR IMPLIED, REGARDING THE PRODUCTS OR SERVICES DESCRIBED HEREIN OR THEIR USE OR APPLICABILITY. ALL SALES ARE GOVERNED BY DANIEL'S TERMS AND CONDITIONS, WHICH ARE AVAILABLE UPON REQUEST. WE RESERVE THE RIGHT TO MODIFY OR IMPROVE THE DESIGNS OR SPECIFICATIONS OF SUCH PRODUCTS AT ANY TIME.

DANIEL DOES NOT ASSUME RESPONSIBILITY FOR THE SELECTION, USE OR MAINTENANCE OF ANY PRODUCT. RESPONSIBILITY FOR PROPER SELECTION, USE AND MAINTENANCE OF ANY DANIEL PRODUCT REMAINS SOLELY WITH THE PURCHASER AND END-USER.

TO THE BEST OF DANIEL'S KNOWLEDGE THE INFORMATION HEREIN IS COMPLETE AND ACCURATE. DANIEL MAKES NO WARRANTIES, EXPRESSED OR IMPLIED, INCLUDING THE IMPLIED WARRANTIES OF MERCHANTABILITY AND FITNESS FOR A PARTICULAR PURPOSE WITH RESPECT TO THIS MANUAL AND, IN NO EVENT, SHALL DANIEL BE LIABLE FOR ANY INCIDENTAL, PUNITIVE, SPECIAL OR CONSEQUENTIAL DAMAGES INCLUDING, BUT NOT LIMITED TO, LOSS OF PRODUCTION, LOSS OF PROFITS, LOSS OF REVENUE OR USE AND COSTS INCURRED INCLUDING WITHOUT LIMITATION FOR CAPITAL, FUEL AND POWER, AND CLAIMS OF THIRD PARTIES.

PRODUCT NAMES USED HEREIN ARE FOR MANUFACTURER OR SUPPLIER IDENTIFICATION ONLY AND MAY BE TRADEMARKS/ REGISTERED TRADEMARKS OF THESE COMPANIES.

Warranty and Limitations

1. **LIMITED WARRANTY:** Subject to the limitations contained in Section 2 herein, Daniel Measurement & Control, Inc. (“Daniel”) warrants that the licensed firmware embodied in the Goods will execute the programming instructions provided by Daniel, and that the Goods manufactured by Daniel will be free from defects in materials or workmanship under normal use and care and Services will be performed by trained personnel using proper equipment and instrumentation for the particular Service provided. The foregoing warranties will apply until the expiration of the applicable warranty period. Goods are warranted for twelve (12) months from the date of initial installation or eighteen (18) months from the date of shipment by Daniel, whichever period expires first. Consumables and Services are warranted for a period of 90 days from the date of shipment or completion of the Services. Products purchased by Daniel from a third party for resale to Buyer (“Resale Products”) shall carry only the warranty extended by the original manufacturer. Buyer agrees that Daniel has no liability for Resale Products beyond making a reasonable commercial effort to arrange for procurement and shipping of the Resale Products. If Buyer discovers any warranty defects and notifies Daniel thereof in writing during the applicable warranty period, Daniel shall, at its option, correct any errors that are found by Daniel in the firmware or Services or repair or replace F.O.B. point of manufacture that portion of the Goods or firmware found by Daniel to be defective, or refund the purchase price of the defective portion of the Goods/Services. All replacements or repairs necessitated by inadequate maintenance, normal wear and usage, unsuitable power sources or environmental conditions, accident, misuse, improper installation, modification, repair, use of unauthorized replacement parts, storage or handling, or any other cause not the fault of Daniel are not covered by this limited warranty, and shall be at Buyer’s expense. Daniel shall not be obligated to pay any costs or charges incurred by Buyer or any other party except as may be agreed upon in writing in advance by Daniel. All costs of dismantling, reinstallation and freight and the time and expenses of Daniel’s personnel and representatives for site travel and diagnosis under this warranty clause shall be borne by Buyer unless accepted in writing by Daniel. Goods repaired and parts replaced by Daniel during the warranty period shall be in warranty for the remainder of the original warranty period or ninety (90) days, whichever is longer. This limited warranty is the only warranty made by Daniel and can be amended only in a writing signed by Daniel. THE WARRANTIES AND REMEDIES SET FORTH ABOVE ARE EXCLUSIVE. THERE ARE NO REPRESENTATIONS OR WARRANTIES OF ANY KIND, EXPRESS OR IMPLIED, AS TO MERCHANTABILITY, FITNESS FOR PARTICULAR PURPOSE OR ANY OTHER MATTER WITH RESPECT TO ANY OF THE GOODS OR SERVICES. Buyer acknowledges and agrees that corrosion or erosion of materials is not covered by this warranty.

2. **LIMITATION OF REMEDY AND LIABILITY:** Daniel shall not be liable for damages caused by delay in performance. The remedies of Buyer set forth in this agreement are exclusive. In no event, regardless of the form of the claim or cause of action (whether based in contract, infringement, negligence, strict liability, other tort or otherwise), shall Daniel’s liability to Buyer and/or its customers exceed the price to Buyer of the specific goods manufactured or services provided by Daniel giving rise to the claim or cause of action. Buyer agrees that in no event shall Daniel’s liability to Buyer and/or its customers extend to include incidental, consequential or punitive damages. The term “consequential damages” shall include, but not be limited to, loss of anticipated profits, revenue or use and costs incurred including without limitation for capital, fuel and power, and claims of Buyer’s customers.

Contents

Chapter 1	Introduction.....	11
	1.1 Purpose of this manual.....	11
	1.2 Description of the Model 788DVC Digital Control Valves.....	11
	1.3 Agency certifications for control valves Models 788DVC Digital.....	46
Chapter 2	Operating conditions and specifications.....	49
	2.1 Operating conditions for the control valve.....	49
	2.2 Specifications for the control valve.....	52
Chapter 3	Control valve handling.....	57
	3.1 Receive the control valve.....	57
	3.2 Store the control valve.....	57
Chapter 4	Prepare the control valve for use.....	59
	4.1 Lifting conditions.....	59
	4.2 Lifting requirements for personnel.....	60
	4.3 Configure the control valve.....	62
Chapter 5	Installation prerequisites.....	65
	5.1 Pre-start checks.....	65
	5.2 Torque information.....	65
	5.3 Torque values (flanges).....	66
	5.4 Torque pattern sequences.....	66
	5.5 Tools required for control valve installation.....	66
Chapter 6	Installation procedure.....	67
	6.1 External components assembly.....	67
Chapter 7	Testing the product.....	69
	7.1 Commission the control valve.....	69
Chapter 8	Operation parameters.....	71
	8.1 Control valve normal operation.....	71
	8.2 Operation accessories.....	71
	8.3 Operation overview.....	71
Chapter 9	Planned maintenance.....	73
	9.1 Maintenance considerations.....	73
	9.2 Tools required for mechanical components.....	73
	9.3 Disassemble/Assemble the control valve.....	73
	9.4 Mechanical assembly.....	76
	9.5 Planned maintenance tasks.....	80
Chapter 10	Corrective maintenance.....	83

	10.1 Control valve troubleshooting.....	83
	10.2 Verify the return to operational condition.....	84
Chapter 11	Spare parts.....	85
	11.1 Recommended spare parts.....	85
Chapter 12	Decommission.....	89
	12.1 Shut down the control valve.....	89
	12.2 Shipment of the control valve.....	89
Appendix A	Needle valve.....	91
	A.1 Disassembly and assembly	91
	A.2 Needle valve.....	92
	A.3 Order spare parts.....	93

1 Introduction

1.1 Purpose of this manual

This manual provides guidance to owners and personnel in the installation, operation and maintenance of the *Daniel™ Series 788DVC Digital Control Valves manual, 3-9008-556*. It is imperative that product owners and operation personnel read and follow the information contained in this manual to ensure that the control valve is installed correctly and is operating according to the design certifications and safety considerations.

1.2 Description of the Model 788DVC Digital Control Valves

1.2.1 General features of the Digital control valve

The Daniel™ Series 788DVC Digital Control Valve operates on a balanced piston principle, spring biased (loaded) to the closed position.

The Daniel Series 788DVC Digital Control Valves have the following characteristics:

- Modular construction: All internal parts including seat ring can be removed with the cylinder assembly without disturbing line connections.
- No diaphragms or stuffing boxes
- 45° body design assures high capacity
- Positive shut-off
- Uniform speed-of-response
- Linear control
- O-ring plus metal-to-metal seat
- Pilots and other optional accessories enable the valve to perform a variety of control functions such as back pressure control, regulating rate-of-flow, pressure relief, surge control, etc.

1.2.2 Control valve applications

The Daniel Model 788DVC Digital Control Valve is a solenoid operated device designed to provide precise flow rate control and batch delivery of liquid products. It is used in conjunction with an electronic batch control device. The Model 788DVC valve is automatically controlled by preset for low flow start-up, high flow rate control, low flow shut-down, and final shut-off. It also provides for maximum flow meter accuracy by maintaining a constant flow rate in applications with varying line pressure. The Model 788DVC features an external pilot control loop that consists of a normally open solenoid pilot, a normally closed solenoid pilot, strainer and opening/closing speed controls.

**CAUTION****EQUIPMENT DAMAGE**

Read the entire recommended procedure for all installation operations and maintenance procedures before attempting to install or disassemble the valve. Disassembly of this cylinder assembly is different from previous Daniel Control Valves and requires strict adherence to the procedures outlined in this manual.

Failure to read and comply with these procedures could result in damage to the equipment and compromise in the integrity of the operation.

1.2.3 Operation overview of the control valve

The Model 788DVC Series Control Valve operates on a balanced-piston principle. When pressure on both sides of the piston are equalized, a spring located on top of the piston acts as a differential force and closes the piston. When the pressure against the bottom of the piston exceeds the pressure plus the force of the spring exerted against the top of the piston, spring tension is overcome, and the valve opens. See Figure 1-1 for more information.

These valves are normally closed (N.C.) and they will open when both solenoids are energized. The valves are fail-safe as they close upon loss of power. They use the line product as the source of hydraulic power to open and close the main valve piston. An electrical supply controlled by an electronic preset is the source of power for energizing the two solenoids.

These valves are used mainly for batching and they provide a means of reducing the rate of flow on on startup and before final shut-off of a predetermined delivery. This minimizes surges of pressure and line shock and ensures $\pm 1/4$ gallon shut-off (sizes 2 inch - 8 inch) of the preset volume.

The total system generally consists of three pieces of equipment: (1) a flow meter, (2) an electronic preset with digital control, and (3) a digital electric control valve. The electronic preset is the device used to set the predetermined volume of liquid that is to be delivered by the valve.

Operational sequence

With both solenoids de-energized, the main valve is closed as shown in Figure 1-1. The main valve can be infinitely positioned anywhere between 0 - 100% open by digital control of the solenoids. With both solenoids energized, as shown in Figure 1-2, the valve begins to open. It will only open to the programmed flow rate set in the electronic preset. Normally, the electronic preset is programmed to digitally control low flow startup, maximum flow rate, low flow rate before shut-off and no flow. The electronic preset will automatically energize and de-energize the solenoids to position the main valve to limit the required flow rate. When the required flow rate is reached, the solenoids will be as shown in Figure 1-2. This hydraulically locks the main valve piston in position. Should flow increase, the valve will close slightly to adjust to the required flow rate. All of the positioning is done by digitally controlling the two solenoids as shown in Figure 1-1, Figure 1-2 and Figure 1-3.

Closed position

The normally closed solenoid is closed. The normally open solenoid is open. Y-port (P3) to Z-port (P2) is closed. X-port (P1) and Y-port (P3) pressures are balanced. The main valve spring being the differential force, closes the position and keeps it seated. (See below.)

Figure 1-1: Closed position

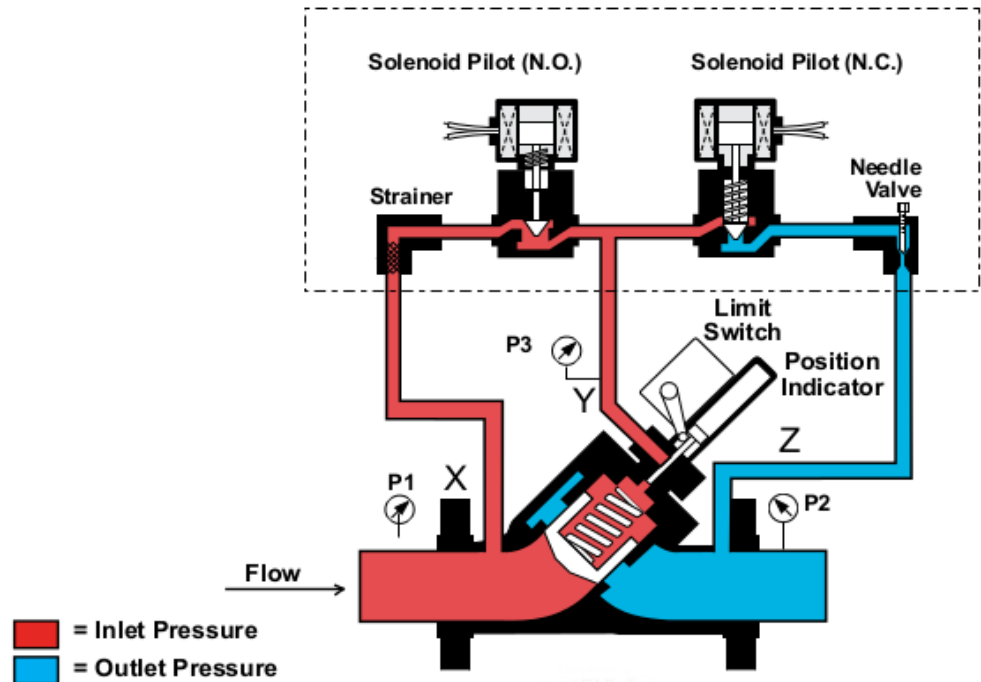

Open - control position

The normally closed solenoid is closed. The normally open solenoid is closed. Y-port (P3) to Z-port (P2) is closed. X-port (P1) to Y-port (P3) is closed. The product cannot flow to or from the top of the piston. The piston is hydraulically locked in position until the electronics preset commands the valve to open or close as required to maintain the desired high flow rate, or low flow rate. (See below.)

Figure 1-2: Open - control position

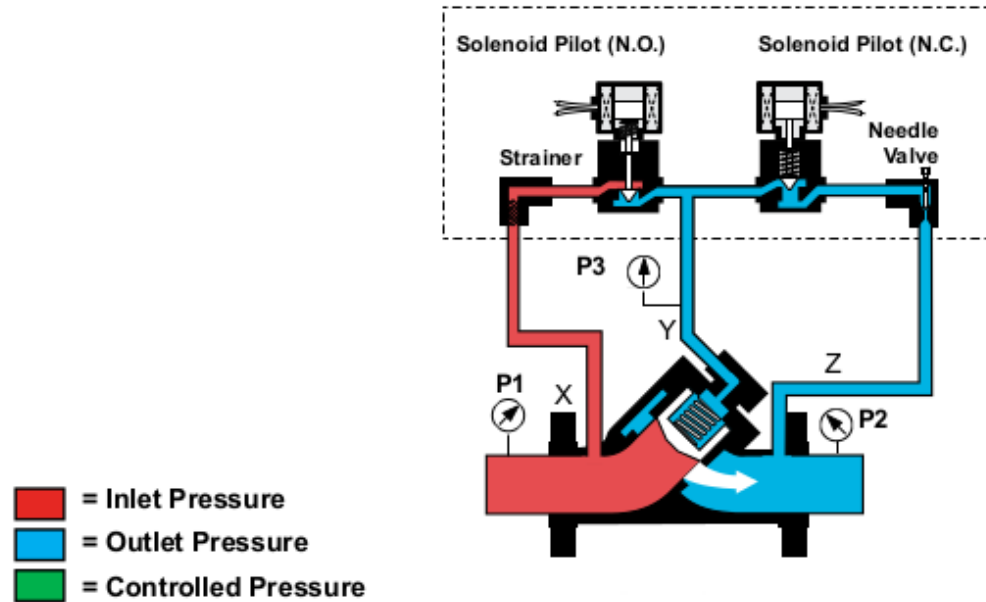

Open position (no control)

The normally closed solenoid is open. The normally open solenoid is closed. Y-port (P3) is open to Z-port (P2). X-port (P1) is closed off by the normally open solenoid. The pressure on the bottom of the piston (P1) is greater than the pressure at (P3) plus the spring force; (P1 minus P2) is equal to or greater than the spring force. Therefore, (P1) pressure pushes the piston open. No flow control is required. (See below.)

Figure 1-3: Open position (no control)

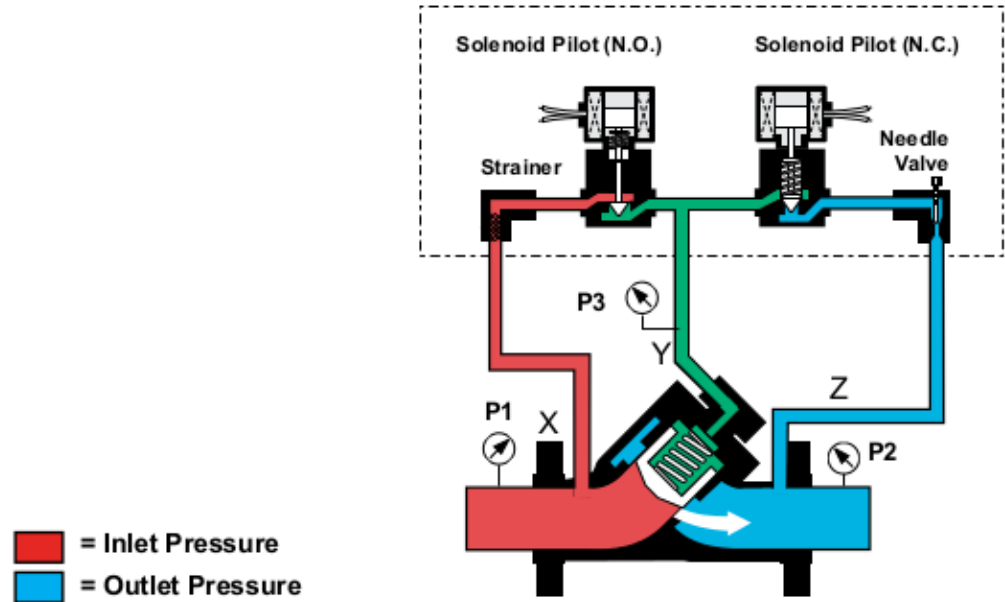

1.2.4 Parts list for the Series 788DVC Control Valves

Figure 1-4: Part description for a series 788DVC Control Valve NPS 2-8

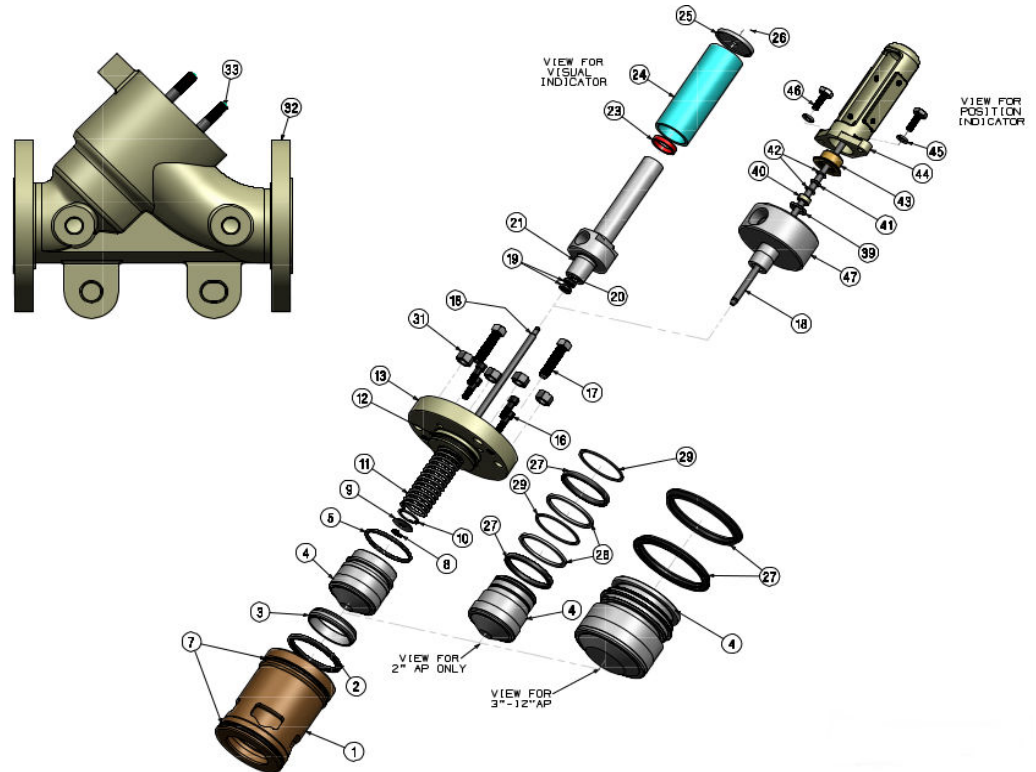

NOTICE

Item numbers are not meant to be consecutively numbered.

Table 1-1: Part description for a Series 788DVC Control Valve NPS 2

Item number	Description		Part number	Quantity
			2 inch	
1	Cylinder	Standard	520471-690	1
2	O-ring	Buna-N	1500399	1
		EPR	1500399-005	
		FFKM	1500399-075	
		NBR (Low-swell)	1500399-120	
		CR	1500399-116	
		FKM	1500399-022	
		FKM GFLT	1500399-027	
		FKM V1289	1500399-029	

Table 1-1: Part description for a Series 788DVC Control Valve NPS 2 (continued)

Item number	Description		Part number	Quantity
			2 inch	
3	Seat ring	Standard	520026-690	1
4	Piston	Standard	520024-690	1
		AP option	520024-693	
5	O-ring	Buna-N	152073	1
		EPR	152073-005	
		FFKM	152073-075	
		NBR (Low-swell)	152073-120	
		CR	152073-116	
		FKM	152073-022	
		FKM GFLT	152073-027	
		FKM V1289	152073-029	
7	O-ring	Buna-N	157000	2
		EPR	157000-005	
		FFKM	157000-075	
		NBR (Low-swell)	157000-120	
		CR	157000-116	
		FKM	157000-022	
		FKM GFLT	157000-027	
		FKM V1289	157000-029	
8	Retaining ring		1500408	1
9	Washer		540032	1
10	Retaining ring		156488	1
11	Spring	Light (blue)	530031	1
		Medium (bronze)	530029	
12	O-ring	Buna-N	157029	1
		EPR	157029-005	
		FFKM	157029-075	
		NBR (Low-swell)	157029-120	
		CR	157029-116	
		FKM	157029-022	
		FKM GFLT	157029-027	
		FKM V1289	157029-029	

Table 1-1: Part description for a Series 788DVC Control Valve NPS 2 (continued)

Item number	Description		Part number	Quantity
			2 inch	
13	Cylinder head	Standard	520056-510M	1
16	Screw		151066	4
17	Jack-out screws		150691	2
18	Indicator stem visual		520183-690	1
	Indicator stem micro-switch		520183-691	
19	Magnet		1500410	2
20	Retaining ring		153946	1
21	Indicator adapter		540081-690M	1
22	Cap plug		154769	1
23	Ring magnet		1500409	1
24	Indicator housing		540082-690	1
25	Indicator top		540084-690	1
26	Screw		151469	1
27	Bal-seal		159775	2
28	Piston seal retainer		520027-690	2
29	External retaining ring		156576	2
31	Nuts		151546 M	4
32	Valve body	class 150	521001M	1
		class 300	523001M	
		DIN PN 16	521001-016M	
		DIN PN 40	523001-040M	
33	Studs		151309M	4
34	Pipe plug		154721	2
38	Cap plug		154774	1
39	O-ring	Buna-N	157012	1
		EPR	157012-005	
		FFKM	157012-075	
		NBR (Low-swell)	157012-120	
		CR	157012-116	
		FKM	157012-022	
		FKM GFLT	157012-027	
		FKM V1289	157012-029	

Table 1-1: Part description for a Series 788DVC Control Valve NPS 2 (continued)

Item number	Description		Part number	Quantity
			2 inch	
40	Seal retainer		540188-500	1
41	O-ring	Buna-N 152096	152096	1
		EPR	152096-005	
		FFKM	152096-075	
		NBR (Low-swell)	152096-120	
		CR	152096-116	
		FKM	152096-022	
		FKM GFLT	152096-027	
		FKM V1289	152096-029	
42	Backup ring		157172	2
43	Upper bearing		540189-500	1
44	Indicator guard		540082-400	1
45	Lock washer		152119	2
46	Screws		150727	2
47	Indicator adapter		540081-500M	1
48	Cap plug		154774	1
50	Set Screw		150975	1
A	Cylinder assembly class 150 and 300	Without indicator		
		Buna-N	520075-690	1
		EPR	520075-697	1
		FFKM	520075-695	1
		NBR (Low-swell)	520075-696	1
		CR	520075-693	1
		FKM	520075-692	1
		FKM GFLT	520075-69G	1
		FKM V1289	520075-69M	1
		With visual indicator		
		Buna-N	520575-690	1
		EPR	520575-697	1
		FFKM	520575-695	1
		NBR (Low-swell)	520575-696	1
CR	520575-693	1		

Table 1-1: Part description for a Series 788DVC Control Valve NPS 2 (continued)

Item number	Description		Part number	Quantity
			2 inch	
		FKM	520575-692	1
		FKM GFLT	520575-69G	1
		FKM V1289	520575-69M	1
		With standard indicator		
		Buna-N	520175-690	1
		EPR	520175-697	1
		FFKM	520175-695	1
		NBR (Low-swell)	520175-696	1
		CR	520175-693	1
		FKM	520175-692	1
		FKM GFLT	520175-69G	1
		FKM V1289	520175-69M	1

Table 1-2: Part description for a Series 788DVC Control Valve NPS 3

Item number	Description		Part number	Quantity
			3 inch	
1	Cylinder	Standard	530471-690	1
		High-pressure	536471-690	1
2	O-ring	Buna-N	1500480	1
		EPR	1500480-005	
		FFKM	1500480-075	
		NBR (Low-swell)	1500480-120	
		CR	1500480-116	
		FKM	1500480-022	
		FKM GFLT	1500480-027	
FKM V1289	1500480-029			
3	Seat ring	Standard	530026-690	1
		High-pressure	536024-610	
4	Piston	Standard	530024-690	1
		AP option	530024-693	
5	O-ring	Buna-N	152075	1
		EPR	152075-005	
		FFKM	152075-075	

Table 1-2: Part description for a Series 788DVC Control Valve NPS 3 (continued)

Item number	Description		Part number	Quantity
			3 inch	
		NBR (Low-swell)	152075-120	
		CR	152075-116	
		FKM	152075-022	
		FKM GFLT	152075-027	
		FKM V1289	152075-029	
6	Backup ring		157186	2
7	O-ring	Buna-N	152095	2
		EPR	152095-005	
		FFKM	152095-075	
		NBR (Low-swell)	152095-120	
		CR	152095-116	
		FKM	152095-022	
		FKM GFLT	152095-027	
		FKM V1289	152095-029	
8	Retaining ring		1500408	1
9	Washer		540032	1
10	Retaining ring		156488	1
11	Spring	Light (blue)	540031	1
		Medium (bronze)	540029	
12	O-ring	Buna-N	159575	1
		EPR	159575-005	
		FFKM	159575-075	
		NBR (Low-swell)	159575-120	
		CR	159575-116	
		FKM	159575-022	
		FKM GFLT	159575-027	
		FKM V1289	159575-029	
13	Cylinder head	Standard	530056-510 M	1
16	Screw		151012	6
17	Jack-out screws		150695	2
18	Indicator stem visual		530183-690	1
	Indicator stem micro-switch		530183-691	

Table 1-2: Part description for a Series 788DVC Control Valve NPS 3 (continued)

Item number	Description		Part number	Quantity
			3 inch	
19	Magnet		1500410	2
20	Retaining ring		153946	1
21	Indicator adapter		540081-690M	1
22	Cap plug		154769	1
23	Ring magnet		1500409	1
24	Indicator housing		540082-690	1
25	Indicator top		540084-690	1
26	Screw		151469	1
27	Bal-seal		159714	2
31	Nuts		151547M	4
32	Valve body	class 150	531001M	1
		class 300	533001M	
		DIN PN 16	531001-016M	
		DIN PN 40	533001-040M	
33	Studs		151305M	4
34	Pipe plug		154721	2
38	Cap plug		154774	1
39	O-ring	Buna-N	157012	1
		EPR	157012-005	
		FFKM	157012-075	
		NBR (Low-swell)	157012-120	
		CR	157012-116	
		FKM	157012-022	
		FKM GFLT	157012-027	
		FKM V1289	157012-029	
40	Seal retainer		540188-500	1
41	O-ring	Buna-N	152096	1
		EPR	152096-005	
		FFKM	152096-075	
		NBR (Low-swell)	152096-120	
		CR	152096-116	
		FKM	152096-022	

Table 1-2: Part description for a Series 788DVC Control Valve NPS 3 (continued)

Item number	Description		Part number	Quantity
			3 inch	
		FKM GFLT	152096-027	
		FKM V1289	152096-029	
42	Backup ring		157172	2
43	Upper bearing		540189-500	1
44	Indicator guard		540082-400	1
45	Lock washer		152119	2
46	Screws		150727	2
47	Indicator adapter		540081-500M	1
48	Cap plug		154774	1
50	Set Screw		150975	1
A	Cylinder assembly class 150 and 300	Without indicator		
		Buna-N	530075-690	1
		EPR	530075-697	1
		FFKM	530075-695	1
		NBR (Low-swell)	530075-696	1
		CR	530075-693	1
		FKM	530075-692	1
		FKM GFLT	530075-69G	1
		FKM V1289	530075-69M	1
		With visual indicator		
		Buna-N	530575-690	1
		EPR	530575-697	1
		FFKM	530575-695	1
		NBR (Low-swell)	530575-696	1
		CR	530575-693	1
		FKM	530575-692	1
		FKM GFLT	530575-69G	1
		FKM V1289	530575-69M	1
		With standard indicator		
		Buna-N	530175-690	1
EPR	530175-697	1		
FFKM	530175-695	1		

Table 1-2: Part description for a Series 788DVC Control Valve NPS 3 (continued)

Item number	Description		Part number	Quantity
			3 inch	
		NBR (Low-swell)	530175-696	1
		CR	530175-693	1
		FKM	530175-692	1
		FKM GFLT	530175-690G	1
		FKM V1289	530175-69M	1

Table 1-3: Part description for a Series 788DVC Control Valve NPS 4

Item number	Description		Part number	Quantity
			4 inch	
1	Cylinder	Standard	540471-690	1
		High-pressure	546471-690	
2	O-ring	Buna-N	152080	1
		EPR	152080-005	
		FFKM	152080-075	
		NBR (Low-swell)	152080-120	
		CR	152080-116	
		FKM	152080-022	
		FKM GFLT	152080-027	
		FKM V1289	152080-029	
3	Seat ring		540026-690	1
4	Piston	Standard	540024-690	1
		AP option	540024-693	
5	O-ring	Buna-N	152078	1
		EPR	152078-005	
		FFKM	152078-075	
		NBR (Low-swell)	152078-120	
		CR	152078-116	
		FKM	152078-022	
		FKM GFLT	152078-027	
		FKM V1289	152078-029	
6	Backup ring		157188	2
7	O-ring	Buna-N	152094	2
		EPR	152094-005	

Table 1-3: Part description for a Series 788DVC Control Valve NPS 4 (continued)

Item number	Description		Part number	Quantity
			4 inch	
		FFKM	152094-075	
		NBR (Low-swell)	152094-120	
		CR	152094-116	
		FKM	152094-022	
		FKM GFLT	152094-027	
		FKM V1289	152094-029	
8	Retaining ring		1500408	1
9	Washer		540032	1
10	Retaining ring		156488	1
11	Spring	Light (blue)	540031	1
		Medium (bronze)	540029	
12	O-ring	Buna-N	157032	1
		EPR	157032-005	
		FFKM	157032-075	
		NBR (Low-swell)	157032-120	
		CR	157032-116	
		FKM	157032-022	
		FKM GFLT	152078-027	
FKM V1289	152078-029			
13	Cylinder head	Standard	540056-510M	1
16	Screw		151012	6
17	Jack-out screws		150695	2
18	Indicator stem visual		540183-690	1
	Indicator stem micro-switch		540183-691	
19	Magnet		1500410	2
20	Retaining ring		153946	1
21	Indicator adapter		540081-690M	1
22	Cap plug		154769	1
23	Ring magnet		1500409	1
24	Indicator housing		540082-690	1
25	Indicator top		540084-690	1
26	Screw		151469	1

Table 1-3: Part description for a Series 788DVC Control Valve NPS 4 (continued)

Item number	Description		Part number	Quantity
			4 inch	
27	Bal-seal		159715	2
31	Nuts		151547M	6
32	Valve body	class 150	541001M	1
		class 300	543001M	
		DIN PN 16	541001-016M	
		DIN PN 40	543001-040M	
33	Studs		151305M	6
34	Pipe plug		154721	2
38	Cap plug		154774	1
39	O-ring	Buna-N	157012	1
		EPR	157012-005	
		FFKM	157012-075	
		NBR (Low-swell)	157012-120	
		CR	157012-116	
		FKM	157012-022	
		FKM GFLT	157012-027	
		FKM V1289	157012-029	
40	Seal retainer		540188-500	1
41	O-ring	Buna-N	152096	1
		EPR	152096-005	
		FFKM	152096-075	
		NBR (Low-swell)	152096-120	
		CR	152096-116	
		FKM	152096-022	
		FKM GFLT	152096-027	
		FKM V1289	152096-029	
42	Backup ring		157172	2
43	Upper bearing		540189-500	1
44	Indicator guard		540082-400	1
45	Lock washer		152119	2
46	Screws		150727	2
47	Indicator adapter		540081-500M	1

Table 1-3: Part description for a Series 788DVC Control Valve NPS 4 (continued)

Item number	Description	Part number	Quantity	
		4 inch		
48	Cap plug	154774	1	
50	Set Screw	150975	1	
A	Cylinder assembly class 150 and 300	Without indicator		
		Buna-N	540075-690	1
		EPR	540075-697	1
		FFKM	540075-695	1
		NBR (Low-swell)	540075-696	1
		CR	540075-693	1
		FKM	540075-692	1
		FKM GFLT	540075-69G	1
		FKM V1289	540075-69M	1
		With visual indicator		
		Buna-N	540575-690	1
		EPR	540575-697	1
		FFKM	540575-695	1
		NBR (Low-swell)	540575-696	1
		CR	540575-693	1
		FKM	540575-692	1
		FKM GFLT	540575-69G	1
		FKM V1289	540575-69M	1
		With standard indicator		
		Buna-N	540175-690	1
		EPR	540175-697	1
		FFKM	540175-695	1
		NBR (Low-swell)	540175-696	1
		CR	540175-693	1
		FKM	540175-692	1
		FKM GFLT	540175-69G	1
		FKM V1289	540175-69M	1

Table 1-4: Part description for a Series 788DVC Control Valve NPS 6

Item number	Description		Part number	Quantity
			6 inch	
1	Cylinder	Standard	560471-590	1
		High-pressure	566471-590	
2	O-ring	Buna-N	1500407	1
		EPR	1500407-005	
		FFKM	1500407-075	
		NBR (Low-swell)	1500407-120	
		CR	1500407-116	
		FKM	1500407-022	
		FKM GFLT	1500407-027	
		FKM V1289	1500407-029	
3	Seat ring		560026-690	1
4	Piston	Standard	560024-690	1
		AP option	560024-693	
5	O-ring	Buna-N	157002	1
		EPR	157002-005	
		FFKM	157002-075	
		NBR (Low-swell)	157002-120	
		CR	157002-116	
		FKM	157002-022	
		FKM GFLT	157002-027	
		FKM V1289	157002-029	
6	Backup ring		157185	2
7	O-ring	Buna-N	152079	2
		EPR	152079-005	
		FFKM	152079-075	
		NBR (Low-swell)	152079-120	
		CR	152079-116	
		FKM	152079-022	
		FKM GFLT	152079-027	
		FKM V1289	152079-029	
8	Retaining ring		1500408	1
9	Washer		540032	1

Table 1-4: Part description for a Series 788DVC Control Valve NPS 6 (continued)

Item number	Description		Part number	Quantity
			6 inch	
10	Retaining ring		156488	1
11	Spring	Light (blue)	560031	1
		Medium (bronze)	560029	
12	O-ring	Buna-N	159576	1
		EPR	159576-005	
		FFKM	159576-075	
		NBR (Low-swell)	159576-120	
		CR	159576-116	
		FKM	159576-022	
		FKM GFLT	159576-027	
		FKM V1289	159576-029	
13	Cylinder head	Standard	560056-510 M	1
16	Screw		151012	8
17	Jack-out screws		150695	2
18	Indicator stem visual		560183-690	1
	Indicator stem micro-switch		560183-691	
19	Magnet		1500410	2
20	Retaining ring		153946	1
21	Indicator adapter		540081-690M	1
22	Cap plug		154769	1
23	Ring magnet		1500409	1
24	Indicator housing		540082-690	1
25	Indicator top		540084-690	1
26	Screw		151469	1
27	Bal-seal		159716	2
31	Nuts		151553M	8
32	Valve body	class 150	561001M	1
		class 300	563001M	
		DIN PN 16	561001-016M	
		DIN PN 40	563001-040M	
33	Studs		151347M	8
34	Pipe plug		154721	2

Table 1-4: Part description for a Series 788DVC Control Valve NPS 6 (continued)

Item number	Description		Part number	Quantity
			6 inch	
38	Cap plug		154774	1
39	O-ring	Buna-N	157012	1
		EPR	157012-005	
		FFKM	157012-075	
		NBR (Low-swell)	157012-120	
		CR	157012-116	
		FKM	157012-022	
		FKM GFLT	157012-027	
		FKM V1289	157012-029	
40	Seal retainer		540188-500	1
41	O-ring	Buna-N 152096	152096	1
		EPR	152096-005	
		FFKM	152096-075	
		NBR (Low-swell)	152096-120	
		CR	152096-116	
		FKM	152096-022	
		FKM GFLT	152096-027	
		FKM V1289	152096-029	
42	Backup ring		157172	2
43	Upper bearing		540189-500	1
44	Indicator guard		540082-400	1
45	Lock washer		152119	2
46	Screws		150727	2
47	Indicator adapter		540081-500M	1
48	Cap plug		154774	1
50	Set Screw		150975	1
A	Cylinder assembly class 150 and 300	Without indicator		
		Buna-N	560075-690	1
		EPR	560075-697	1
		FFKM	560075-695	1
		NBR (Low-swell)	560075-696	1
		CR	560075-693	1

Table 1-4: Part description for a Series 788DVC Control Valve NPS 6 (continued)

Item number	Description		Part number	Quantity
			6 inch	
		FKM	560075-692	1
		FKM GFLT	560075-69G	1
		FKM V1289	560075-69M	1
		With visual indicator		
		Buna-N	560575-690	1
		EPR	560575-697	1
		FFKM	560575-695	1
		NBR (Low-swell)	560575-696	1
		CR	560575-693	1
		FKM	560575-692	1
		FKM GFLT	560575-69G	1
		FKM V1289	560575-69M	1
		With standard indicator		
		Buna-N	560175-690	1
		EPR	560175-697	1
		FFKM	560175-695	1
		NBR (Low-swell)	560175-696	1
		CR	560175-693	1
		FKM	560175-692	1
		FKM GFLT	560175-69G	1
		FKM V1289	560175-69M	1

Table 1-5: Part description for a Series 788DVC Control Valve NPS 8

Item number	Description		Part number	Quantity
			8 inch	
1	Cylinder	Standard	580471-500	1
		High-pressure	586471-500	1
2	O-ring	Buna-N	157006	1
		EPR	157006-005	
		FFKM	157006-075	
		NBR (Low-swell)	157006-120	
		CR	157006-116	

Table 1-5: Part description for a Series 788DVC Control Valve NPS 8 (continued)

Item number	Description		Part number	Quantity
			8 inch	
		FKM	157006-022	
		FKM GFLT	157006-027	
		FKM V1289	157006-029	
3	Seat ring	Standard	580026-500	1
		High-pressure	580026-600	
4	Piston	Standard	580057-600	1
		AP option	580057-630	
5	O-ring	Buna-N	157005	1
		EPR	157005-005	
		FFKM	157005-075	
		NBR (Low-swell)	157005-120	
		CR	157005-116	
		FKM	157005-022	
		FKM GFLT	157005-027	
		FKM V1289	157005-029	
6	Backup ring		157198	2
7	O-ring	Buna-N	157004	2
		EPR	157004-005	
		FFKM	157004-075	
		Low-swell NBR	157004-120	
		CR	157004-116	
		FKM	157004-022	
		FKM GFLT	157004-027	
		FKM V1289	157004-029	
11	Spring	Light (blue)	580031	1
		Medium (bronze)	580029	
12	O-ring	Buna-N	157074	1
		EPR	157074-005	
		FFKM	157074-075	
		NBR (Low-swell)	157074-120	
		CR	157074-116	
		FKM	157074-022	

Table 1-5: Part description for a Series 788DVC Control Valve NPS 8 (continued)

Item number	Description		Part number	Quantity
			8 inch	
		FKM GFLT	157074-027	
		FKM V1289	157074-029	
13	Cylinder head	Standard	580056-514M	1
16	Screw	Standard	151072	4
		High-pressure	151038	4
17	Jack-out screws		150696	2
18	Indicator stem micro-switch		580183	1
27	Bal-seal		159651	2
31	Nuts		151558M	4
32	Valve body	class 150	581008M	1
		class 300	583001M	
		DIN PN 16	581001-016M	
		DIN PN 40	583001-040M	
33	Studs		151335M	4
34	Pipe plug		154704	2
38	Cap plug		154774	1
39	O-ring	Buna-N	157012	1
		EPR	157012-005	
		FFKM	157012-075	
		NBR (Low-swell)	157012-120	
		CR	157012-116	
		FKM	157012-022	
		FKM GFLT	157012-027	
		FKM V1289	157012-029	
40	Seal retainer		540188-500	1
41	O-ring	Buna-N 152096	152096	1
		EPR	152096-005	
		FFKM	152096-075	
		NBR (Low-swell)	152096-120	
		CR	152096-116	
		FKM	152096-022	
		FKM GFLT	152096-027	

Table 1-5: Part description for a Series 788DVC Control Valve NPS 8 (continued)

Item number	Description		Part number	Quantity
			8 inch	
		FKM V1289	152096-029	
42	Backup ring		157172	2
43	Upper bearing		540189-500	1
44	Indicator guard		580082-400	1
45	Lock washer		152119	2
46	Screws		150727	2
47	Indicator adapter		540081-500M	1
48	Cap plug		154774	1
50	Set Screw		150975-019	1
A	Cylinder assembly class 150 and 300	Without indicator		
		Buna-N	580075-690	1
		EPR	580075-697	1
		FFKM	580075-695	1
		NBR (Low-swell)	580075-696	1
		CR	580075-693	1
		FKM	580075-692	1
		FKM GFLT	580075-69G	1
		FKM V1289	580075-69M	1
		With standard indicator		
		Buna-N	580175-690	1
		EPR	580175-697	1
		FFKM	580175-695	1
		NBR (Low-swell)	580175-696	1
		CR	580175-693	1
		FKM	580175-692	1
		FKM GFLT	580175-69G	1
		FKM V1289	580175-69M	1



WARNING
EQUIPMENT HAZARD

When the process fluid is liquid ammonia, use this equipment ONLY with CR elastomers. Consult a Daniel representative for assistance. Failure to comply may result in death or serious injury.

Table 1-6: Reference for differential pressure and voltage

Function	Elastomers	Maximum Operational Pressure Differential (Psi)	Voltage					
			110VAC	220VAC	440VAC	12VDC	24VDC	48VDC
Normally open	FKM	150	458815-012	458815-022				
		275	456910-X12	456910-X22	456910-X42	456910-X72	456910-X82	456910-X92
		740	456910-X12	456910-X22	456910-X42	456910-X72	456910-X82	456910-X92
	NBR	150						
		275	456910-X10	456910-X20	456910-X40	456910-X70	456910-X80	
		740	456910-X10	456910-X20	456910-X40	456910-X70	456910-X80	
	CR	150						
		275	456910-X13	456910-X23				
		740	456910-X13	456910-X23				
	EPR	150						
		275	456910-X17	456910-X27				
		740	456910-X17	456910-X27				
	FFKM	150	458815-015	458815-025				
		275	456910-X15	456910-X25			456910-X85	
		740	456910-X15	456910-X25			456910-X85	

Table 1-6: Reference for differential pressure and voltage (continued)

Function	Elastomers	Maximum Operational Pressure Differential (Psi)	Voltage						
			110VAC	220VAC	440VAC	12VDC	24VDC	48VDC	
	FKM For LPG Service	150	458815-019	458815-029	458815-039	458815-079	458815-089	458815-099	
		275	458815-019	458815-029	458815-039	458815-079	458815-089	458815-099	
		740	-	-	-	-	-	-	
	PTFE	150	458815-016	458815-026					
		275	-	-	-	-	-	-	
		740	-	-	-	-	-	-	
	FKM	150	458815-512	458815-522					
		275	456910-XA2	456910-XB2		456910-XE2	456910-XF2	456910-X92	
		740	456910-XA2	456910-XB2		456910-XE2	456910-XF2	456910-X92	
	FFKM	150	458815-515	458815-525					
		275	456910-XA5	456910-XB5					
		740	456910-XA5	456910-XB5					
	FKM For LPG Service	150	458815-529	458815-529					
		275	458815-529	458815-529					
		740	-	-	-	-	-	-	
	Normally open	FKM	150	458800-012	458800-022				
			275	456960-X12	456960-X22	456960-X42		456960-X82	456960-X92
			740	456960-X12	456960-X22	456960-X42		456960-X82	456960-X92
NBR		150							

Table 1-6: Reference for differential pressure and voltage (continued)

Function	Elastomers	Maximum Operational Pressure Differential (Psi)	Voltage					
			110VAC	220VAC	440VAC	12VDC	24VDC	48VDC
		275	456960-X10	456960-X20	456960-X40	456960-X70	456960-X80	
		740	456960-X10	456960-X20	456960-X40	456960-X70	456960-X80	
CR		150						
		275	456960-X13	456960-X23	456960-X43		456960-X83	
		740	456960-X13	456960-X23	456960-X43		456960-X83	
EPR		150						
		275	456960-X17	456960-X27	456960-X47			
		740	456960-X17	456960-X27	456960-X47			
FFKM		150	458800-015	458800-025				
		275	456960-X15	456960-X25			456960-X85	
		740	456960-X15	456960-X25			456960-X85	
FKM For LPG Service		150	458800-019	458800-029	458800-039	458800-079	458800-089	458800-099
		275	458800-019	458800-029	458800-039	458800-079	458800-089	458800-099
		740	-	-	-	-	-	-
FKM		150	458800-512	458800-522				
		275	456960-XA2	456960-XB2		456960-XE2	456960-XF2	
		740	456960-XA2	456960-XB2		456960-XE2	456960-XF2	
FFKM		150	458800-515	458800-525				

Table 1-6: Reference for differential pressure and voltage (continued)

Function	Elastomers	Maximum Operational Pressure Differential (Psi)	Voltage					
			110VA C	220VA C	440VA C	12VDC	24VDC	48VDC
		275	456960 -XA5	456960 -XB5				
		740	456960 -XA5	456960 -XB5				
	FKM For LPG Service	150	458800 -529	458800 -529				
		275	458800 -529	458800 -529				
		740	-	-	-	-	-	-

⚠ WARNING
EQUIPMENT HAZARD
 When the process fluid is liquid ammonia, use this equipment ONLY with CR elastomers. Consult a Daniel representative for assistance.
 Failure to comply may result in death or serious injury.

Figure 1-5: Parts description of 1710 (456910) Control Valve pilot

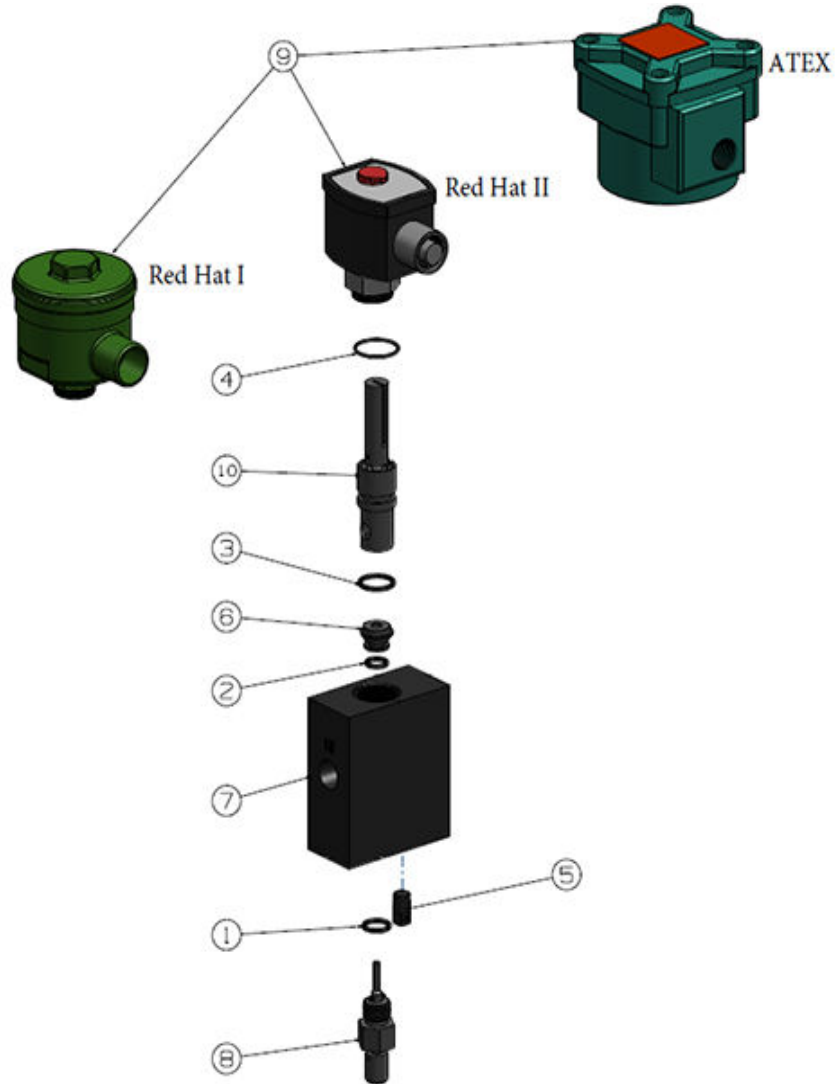

Table 1-7: Parts list for 1710 (456910) pilot used with the 788DVC Control Valve

Item Number	Description	Part Number	Quantity
1	O-ring, NBR	152071	1
	O-ring, EPR	152071-005	1
	O-ring, FFKM	152071-075	1
	O-ring, NBR (Low-swell)	152071-120	1
	O-ring, CR	152071-116	1
	O-ring, FKM	152071-022	1

Table 1-7: Parts list for 1710 (456910) pilot used with the 788DVC Control Valve (continued)

Item Number	Description	Part Number	Quantity
	O-ring, FKM GFLT	152071-027	1
	O-ring, FKM V1289	152071-029	1
2	O-ring, NBR	152076	1
	O-ring, EPR	152076-005	1
	O-ring, FFKM	152076-075	1
	O-ring, NBR (Low-swell)	152076-120	1
	O-ring, CR	152076-116	1
	O-ring, FKM	152076-022	1
	O-ring, FKM GFLT	152076-027	1
	O-ring, FKM V1289	152076-029	1
3	O-ring, NBR	157024	1
	O-ring, EPR	157024-005	1
	O-ring, FFKM	157024-075	1
	O-ring, NBR (Low-swell)	157024-120	1
	O-ring, CR	157024-116	1
	O-ring, FKM	157024-022	1
	O-ring, FKM GFLT	157024-027	1
	O-ring, FKM V1289	157024-029	1
4	O-ring, NBR	157034	1
	O-ring, EPR	157034-005	1
	O-ring, FFKM	157034-075	1
	O-ring, NBR (Low-swell)	157034-120	1
	O-ring, CR	157034-116	1
	O-ring, FKM	157034-022	1
	O-ring, FKM GFLT	157034-027	1
	O-ring, FKM V1289	157034-029	1
5	Plug	157138-024M	1
6	Seat	455016	1
7	Pilot Body (Carbon Steel)	455401-500M	1
	Pilot Body (304 Stainless Steel)	455401-300M	1
8	Manual Operator FKM	455525-001	1
	Manual Operator CR	455525-003	1
	Manual Operator NBR	455525-004	1

Table 1-7: Parts list for 1710 (456910) pilot used with the 788DVC Control Valve (continued)

Item Number	Description	Part Number	Quantity
	Manual Operator FFKM	455525-005	1
	Manual Operator EPR	455525-007	1
	Manual Operator NBR (Low-swell)	455525-008	1
	Manual Operator FKM GFLT	455525-00G	1
	Manual Operator FKM V1289	455525-00M	1
9	Solenoid	See Table 1-8	1
10	Manual Cage Assembly FKM	455525-002	1
	Manual Cage Assembly CR	455525-003	1
	Manual Cage Assembly NBR	455525-004	1
	Manual Cage Assembly FFKM	455525-005	1
	Manual Cage Assembly EPR	455525-007	1
	Manual Cage Assembly NBR (Low-swell)	455525-008	1
	Manual Cage Assembly FKM GFLT	455525-00G	1
	Manual Cage Assembly FKM V1289	455525-00M	1

Table 1-8: Voltages for the 1710 (456910) pilot

Type	Elastomer	Voltage					
		110VAC	220VAC	440VAC	12VDC	24VDC	48VDC
Red Hat I (CSA)	FKM	456810-012	456810-022	456810-042	456810-072	456810-082	456810-092
	NBR	456810-010	456810-020	456810-040	456810-070	456810-080	
	CR	456810-013	456810-023				
	EPR	456810-017	456810-027				
Red Hat II (CSA)	FKM	456810-212	456810-222	456810-242	456810-272	456810-282	456810-292
	NBR	456810-210	456810-220	456810-240	456810-270	456810-280	
	CR	456810-213	456810-223				
	EPR	456810-217	456810-227				

Table 1-8: Voltages for the 1710 (456910) pilot (continued)

Type	Elastomer	Voltage					
		110VAC	220VAC	440VAC	12VDC	24VDC	48VDC
	FKM	A2	456810-0 B2		456810-0 E2	456810-0 F2	456810-0 92
	FFKM	456810-0 A5	456810-0 B5				

! WARNING
EQUIPMENT HAZARD
 When the process fluid is liquid ammonia, use this equipment **ONLY** with CR elastomers.
 Consult a Daniel representative for assistance.
 Failure to comply may result in death or serious injury.

Figure 1-6: Parts description of 1711 (456960) Control Valve pilot

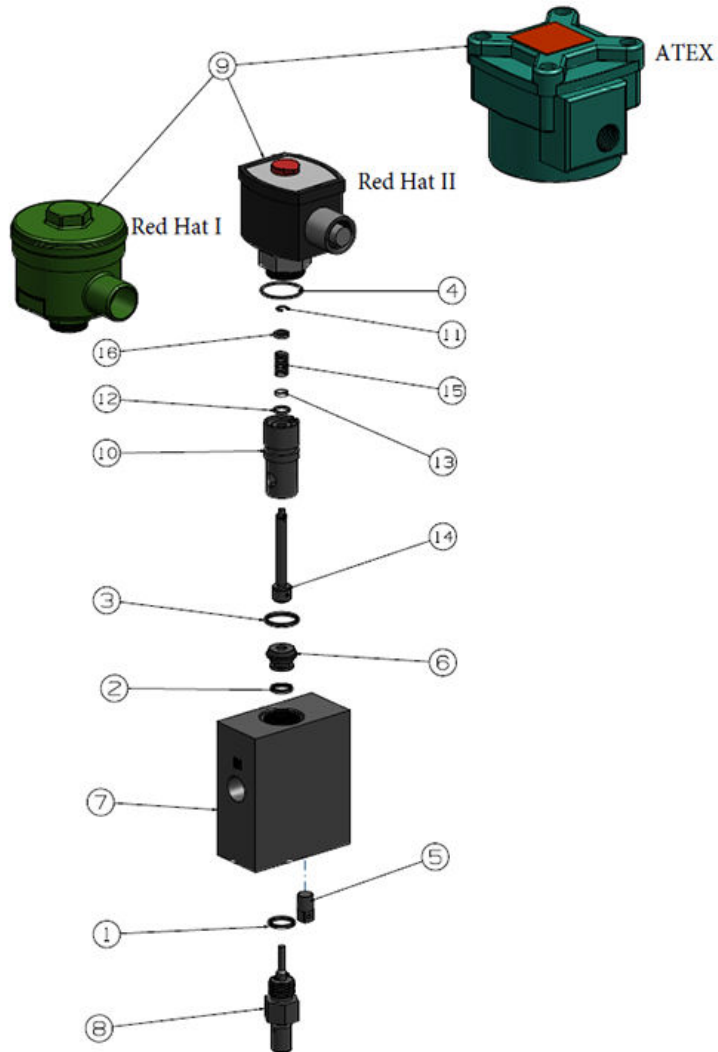

Table 1-9: Parts list for 1711 (456960) pilot used with the 788DVC Control Valve

Item Number	Description	Part Number	Quantity
1	O-ring, NBR	152071	1
	O-ring, EPR	152071-005	1
	O-ring, FFKM	152071-075	1
	O-ring, NBR (Low-swell)	152071-120	1
	O-ring, CR	152071-116	1
	O-ring, FKM	152071-022	1

Table 1-9: Parts list for 1711 (456960) pilot used with the 788DVC Control Valve (continued)

Item Number	Description	Part Number	Quantity
	O-ring, FKM GFLT	152071-027	1
	O-ring, FKM V1289	152071-029	1
2	O-ring, NBR	152076	1
	O-ring, EPR	152076-005	1
	O-ring, FFKM	152076-075	1
	O-ring, NBR (Low-swell)	152076-120	1
	O-ring, CR	152076-116	1
	O-ring, FKM	152076-022	1
	O-ring, FKM GFLT	152076-027	1
	O-ring, FKM V1289	152076-029	1
3	O-ring, NBR	157024	1
	O-ring, EPR	157024-005	1
	O-ring, FFKM	157024-075	1
	O-ring, NBR (Low-swell)	157024-120	1
	O-ring, CR	157024-116	1
	O-ring, FKM	157024-022	1
	O-ring, FKM GFLT	157024-027	1
	O-ring, FKM V1289	157024-029	1
4	O-ring, NBR	157034	1
	O-ring, EPR	157034-005	1
	O-ring, FFKM	157034-075	1
	O-ring, NBR (Low-swell)	157034-120	1
	O-ring, CR	157034-116	1
	O-ring, FKM	157034-022	1
	O-ring, FKM GFLT	157034-027	1
	O-ring, FKM V1289	157034-029	1
5	Plug	157138-024M	1
6	Seat	455016	1
7	Pilot Body (Carbon Steel)	455401-500M	1
	Pilot Body (304 Stainless Steel)	455401-300M	1
8	Manual Operator FKM	455525-001	1
	Manual Operator CR	455525-003	1
	Manual Operator NBR	455525-004	1

Table 1-9: Parts list for 1711 (456960) pilot used with the 788DVC Control Valve (continued)

Item Number	Description	Part Number	Quantity
	Manual Operator FFKM	455525-005	1
	Manual Operator EPR	455525-007	1
	Manual Operator NBR (Low-swell)	455525-008	1
	Manual Operator FKM GFLT	455525-00G	1
	Manual Operator FKM V1289	455525-00M	1
9	Solenoid Red Hat I Viton 110 VAC	See Table 1-10	1
10	Cage	455520-100	1
11	RETAINING RING	153947-019	
12	O-ring, NBR	152067	1
	O-ring, EPR	152067-005	1
	O-ring, FFKM	152067-075	1
	O-ring, NBR (Low-swell)	152067-120	1
	O-ring, CR	152067-116	1
	O-ring, FKM	152067-022	1
	O-ring, FKM GFLT	152067-027	1
	O-ring, FKM V1289	152067-029	1
13	GLYD RING	157160	1
14	POPPET SHAFT ASSEMBLY	456952	1
15	Spring	456957	1
16	Washer	478922	1

Table 1-10: Voltages for the 1711 (456960) pilot

Type	Elastomer	Voltage					
		110VAC	220VAC	440VAC	12VDC	24VDC	48VDC
Red Hat I (CSA)	FKM	478935-012	478935-022	478935-042		478935-082	478935-092
	NBR	478935-010	478935-020	478935-040	478935-070	478935-080	
	CR	478935-013	478935-023	478935-043		478935-083	
	EPR	478935-017	478935-027	478935-047			
	FFKM	478935-015	478935-025			478935-085	

Table 1-10: Voltages for the 1711 (456960) pilot (continued)

Type	Elastomer	Voltage					
		110VAC	220VAC	440VAC	12VDC	24VDC	48VDC
Red Hat II (CSA)	FKM	478935-2 12	478935-2 22	478935-2 42		478935-2 82	478935-2 92
	NBR	478935-2 10	478935-2 20	478935-2 40	478935-2 70	478935-2 80	
	CR	478935-2 13	478935-2 23	478935-2 43		478935-2 83	
	EPR	478935-2 17	478935-2 27	478935-2 47			
	FFKM	478935-2 15	478935-2 25			478935-2 85	
A	FKM	478935-0 A2	478935-0 B2			478935-0 E2	478935-0 F2
	FFKM		478935-0 B5				

! WARNING
EQUIPMENT HAZARD
 When the process fluid is liquid ammonia, use this equipment ONLY with CR elastomers. Consult a Daniel representative for assistance. Failure to comply may result in death or serious injury.

1.3 Agency certifications for control valves Models 788DVC Digital

The following product agency certifications are applicable to the Daniel Control Valves.

Table 1-11: Agency certifications for control valves

Certification type		Description
Pressure equipment		PED
Process temperature	Standard temperature	-26°C to 205°C (-15°F to 400°F)
	Optional temperature	-46°C to 205°C (-51°F to 400°F)
UL and CSA Listed	Electrical	<ul style="list-style-type: none"> Class I, Group C and D, Div. 1; Class II, Group EUL and CSA Listed , F and G
	Environmental	<ul style="list-style-type: none"> Explosion-proof NEMA types 7C, 7D, 9E, 9F and 9G NEMA 4 Weather-proof

Table 1-11: Agency certifications for control valves (continued)

Certification type		Description
INMETRO certification	Electrical	<ul style="list-style-type: none">• Certificate number<ul style="list-style-type: none">– UL-BR 19.1331X• INMETRO marking<ul style="list-style-type: none">– Ex mb IIB T4 Gb (16,1 W)– Ex mb IIB T3 Gb (20,1W)(-15 °C ≤ Tamb ≤ +50 °C)

2 Operating conditions and specifications

2.1 Operating conditions for the control valve

Table 2-1: Operating conditions for the control valve

Condition type	Description
Fluid phase	Liquid
Process temperature	-26°C to 66°C (-15°F to 151°F)
Optional process temperature	-46°C to 121°C (-51°F to 250°F)
Fluid velocity	Operational recommended flow velocity up to 30 ft/sec, beyond this point will result in a high pressure drop and increased wear.
Fluid(s) controlled	<ul style="list-style-type: none"> • Low/Medium viscosity crude oils and condensates • Refined products and intermediates (ie: <i>gasoline, diesel, kerosene, light fuel oils, jet fuel, LPG, butanes, naphtha, alkylate, reformate, straight run gasoline, cat-cracked gasoline</i>) • Petrochemicals (ie: <i>benzene, toluene, xylenes, cumene, olefins, pyrolysis gasoline</i>) • Natural gas liquids
Viscosity limits on valves with pilots	<ul style="list-style-type: none"> • Maximum viscosity for valves with pilots is 440 Cst due to response time of high viscosity pilot
Differential pressure	The maximum allowable differential pressure across a control valve is 5,102 kPa (740 psi). Consult factory for location of first shut down valve.
Atmospheric pressure	Absolute
Sizes (NPS)	2, 3, 4, 6, 8
Pressure class (ANSI)	150, 300
Maximum safe working temperature range	<ul style="list-style-type: none"> • -26°C to 121°C (-15°F to 250°F) • Using FKM O-rings • Temperature range is dependent of O-ring T_{min} and T_{max} • Max temperature of valves with solenoid pilots is standard -26°C to 66°C (-15°F to 151°F) (if applicable), Optional 121°C (250°F) • Consult the factory for other safe working temperatures

Table 2-1: Operating conditions for the control valve (continued)

Condition type	Description
Maximum safe working pressure	Flange connections/Ratings (DIN) for valve sizes DN50 and DN400: <ul style="list-style-type: none"> • DIN PN16 MWP at 120 °C: 16 bar • DIN PN25 MWP at 120 °C: 25 bar • DIN PN40 MWP at 120 °C: 40 bar Flange connections/Ratings (ANSI) for valve sizes 2"-8": <ul style="list-style-type: none"> • Class 150 MWP at 100 °F: 285 psi • Class 300 MWP at 100 °F: 740 psi * MWP: Maximum Working Pressure
Materials of construction	Main valve body: Steel, ASTM-A352 Gr. LCC Main valve cylinder: <ul style="list-style-type: none"> • NPS 2-4: Stainless steel • NPS 6 and larger: Nickel coated steel Main valve piston: Stainless steel (standard) Seat ring: <ul style="list-style-type: none"> • Class 150 and 300: <ul style="list-style-type: none"> — NPS 2-6: Stainless steel — NPS 8: Nickel coated steel O-Rings: <ul style="list-style-type: none"> • Standard: FKM • Optional: CR, EPDM, FKM V1289, NBR, FFKM, FKM GLT • For other material contact the factory External hook up: <ul style="list-style-type: none"> • Class 150 and 300: <ul style="list-style-type: none"> — NPS 2-6: Carbon steel/Stainless steel 10 mm (0.375") — NPS 8: Carbon steel/Stainless steel 13 mm (0.5") Other internal parts: Stainless steel
Valve capacity	C _v is a capacity coefficient that defines as the number of US gpm of water that flows through a valve with a pressure drop of 1 psi across the valve. Daniel valves have the following C _v : <ul style="list-style-type: none"> • NPS 2: 86 gpm • NPS 3: 186 gpm • NPS 4: 309 gpm • NPS 6: 688 gpm • NPS 8: 1296 gpm *C _v based on wide open valve with water temperature at 16°C (60°F)

Condition type	Voltage ⁽¹⁾	Current (Inrush)	Current holding
Solenoid electrical data (150 lb. MOPD)	110/50 Vac	0.71 amps	0.37 amps
	120/60 Vac	0.65 amps	0.34 amps
	220/50 Vac	0.36 amps	0.19 amps
	240/60 Vac	0.33 amps	0.17 amps

⁽¹⁾ DC voltage and 440/480 Vac upon request

2.1.1 Design considerations

Some conditions to consider:

- Service operating pressure
- Service testing pressures
- Service process temperature and ambient site temperatures
- Chemical composition and toxicity of fluid in operating conditions
- Traffic, wind and earthquake at loading site
- Adverse force or stress caused by inadequate supports, attachments, piping, etc.
- Corrosion, erosion, fatigue, etc.
- Decomposition of unstable fluids in operating and test conditions
- Possible damage from external fire
- Mass fluid in process and test conditions



WARNING

FUNCTIONAL AND ENVIRONMENTAL HAZARD

Evaluate the functional and environmental conditions prior to installing a control valve. Install the control valve in a well-designed piping system.

Failure to comply may result in death or serious injury from pipe failure.

2.1.2 Environmental conditions



WARNING

EQUIPMENT HAZARD

Never use this equipment for any purpose other than its intended use.

Failure to comply may result in death, serious personal injury and/or property damage.

Table 2-2: Environmental conditions

Parameter type	Description
Severe service conditions	Ensure that piping or other attachments connected to the valve are not under stress. The design of the control valve has not been assessed for the effects of wind, earthquake loading and severe weather conditions.

Table 2-2: Environmental conditions (continued)

Parameter type	Description
Additional severe service conditions	The valves are designed to be used on liquid applications for crude oil and refined products. The use of aggressive additives or oxygenates requires the use of the Aggressive Products (AP) option. The AP option valve cylinder incorporates cup-seals (PTFE Bal Seals) and an O-ring made from appropriate materials for severe conditions.
Corrosive service	Select the material compatible with the specific processes and atmospheric environments. Implement a periodic inspection and maintenance program to ensure that pressure retaining components are free from corrosion and erosion. The valve is not designed with corrosion allowance. Inspect the valve's metal parts periodically for corrosion and erosion, and inspect the seals and O-rings for wear and chemical deterioration.
Populated areas	For new installations, locate the control valve to an area that has fewer than 10 buildings intended for human occupancy within an area that extends 200 meters (220 yards) radially from the control valve. (Reference: Class 1 Location: U.S. DOT, CFR Title 49: Part 192.5)
Closed, poorly ventilated areas	Install the control valve in a well ventilated area, not less than one meter (approximately three feet) from source of ignition or source of heat which might damage the unit.
Elevation	No limit
Humidity	No limit
Proximity to open flame	Provide fire prevention measures and equipment per local regulations.
Proximity to vehicular traffic	The design of the control valve has not been assessed for the effects of traffic.

2.2 Specifications for the control valve

2.2.1 Interface requirements



WARNING

EXCEEDING REQUIREMENTS HAZARD

Control valve requirements are defined to ensure safe equipment operation. Do not exceed published specifications.

Failure to comply may result in death, serious injury and/or damage to the equipment.

Table 2-3: Interface requirements

Requirements	Description
Hydraulic lines	External hook up: <ul style="list-style-type: none"> • ANSI class 150 and 300: <ul style="list-style-type: none"> — NPS 2-6: Carbon steel/Stainless steel 10 mm (0.375") — NPS 8-16 Carbon steel/Stainless steel 13 mm (0.5") — Can be furnished in metric sizes
Flange type	The mechanical connections for a Series 788DVC control valve NPS 2 to 8 are standard class 150 and 300 ANSI raised face flanges, which are available only in carbon steel. Other types of flange connections are available per customer request for Daniel control valves. For other ANSI ratings or flanges consult the factory engineers. For maximum working pressures at intermediate temperatures refer to ANSI B16.5.

⚠ WARNING

FLANGE SIZE HAZARD

Customers must choose the appropriate size material of the flange for their piping requirements.

Choosing an incorrect flange may cause a pressure leak, resulting in death or serious injury.

2.2.2 Requirements and limitations for installation

NOTICE

Comply with local government regulations and company requirements.

See Figure 2-1 for flow direction.

NOTICE

Flush lines to remove welding bead, pipe scale, etc.

NOTICE

Install the valve in a horizontal line with the cylinder head at the top.

Figure 2-1: Valve orientation

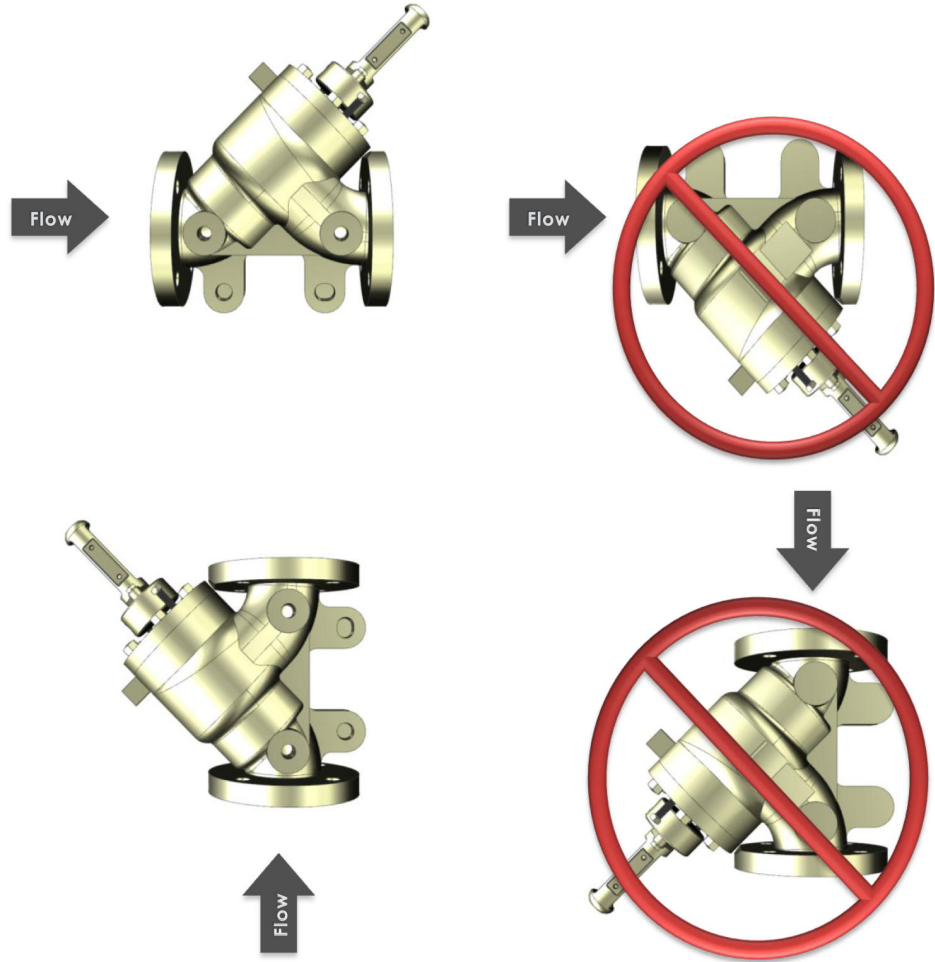

⚠ WARNING
EQUIPMENT HAZARD
Never use this equipment for any purpose other than its intended use.
Failure to comply may result in death, serious personal injury and/or property damage.

2.2.3 Minimum clearances for installation, operation and maintenance

For certified prints, consult the factory.

Figure 2-2: Dimensions of the control valve

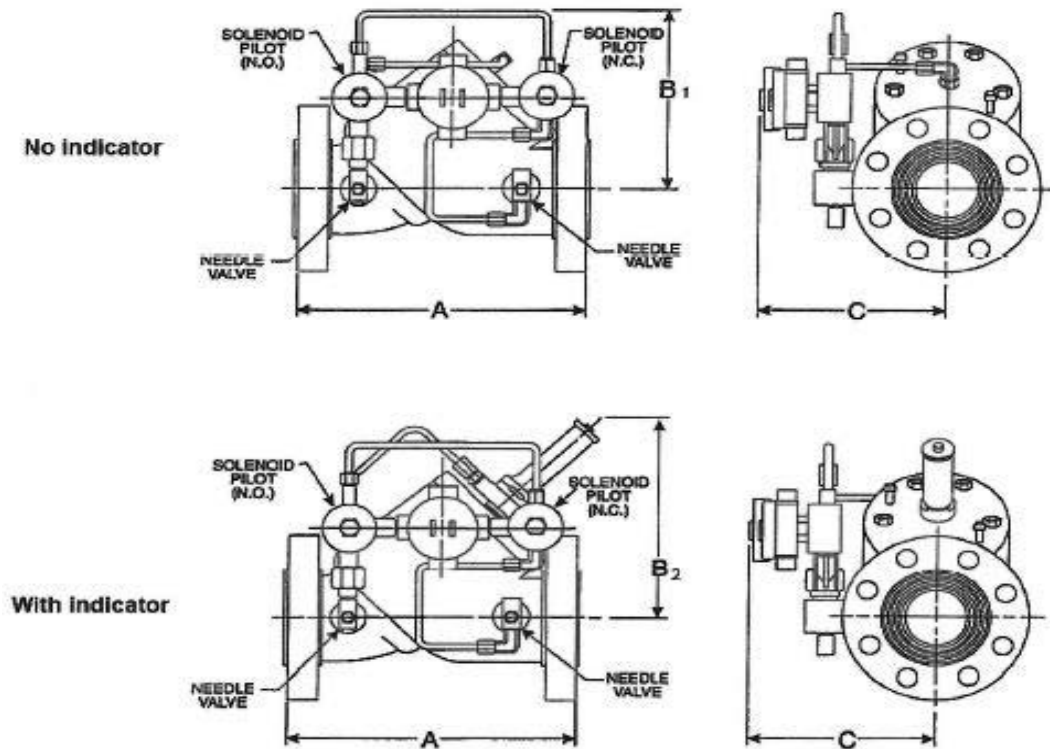

Table 2-4: Weight and volume table for the control valve (Approximate)

Size	150 lb. (ANSI)		300 lb. (ANSI)		150-300 lb. (ANSI)	
	lbs.	Kg.	lbs.	Kg.	Cubic feet	Cubic meters
2"	55	25	60	27	1.66	0.047
3"	95	43	105	48	2.36	0.067
4"	115	52	140	64	2.51	0.071
6"	210	95	250	113	4.84	0.137
8"	400	181	465	211	8.94	0.253

Table 2-5: Dimensions for the control valve

Valve size	A 150# ANSI	A 300# ANSI	B ¹ No indicator	B ² With indicator	C
2"	10-1/4"	10-1/2"	9"	11"	8.252"
	260mm	267 mm	229 mm	279 mm	210 mm
3"	11"	11"	9"	12"	8-3/4"
	279 mm	333 mm	229 mm	305 mm	222 mm
4"	13"	13"	9"	12/1-2"	9"
	330 mm	368 mm	229 mm	318 mm	229 mm
6"	17"	17"	12"	15-3/4"	11"
	432 mm	454 mm	305 mm	400 mm	279 mm
8"	22.25"	22.25"	15"	17.5"	11.75"
	565 mm	591 mm	381 mm	445 mm	298 mm

3 Control valve handling

3.1 Receive the control valve



WARNING

EQUIPMENT HANDLING AND OPERATING HAZARD

Wear personal protective equipment appropriate to the situation when working with the control valve. Adhere to all safety standards and best practices for operating the equipment.

Failure to comply may result in death or serious injury.

3.1.1 Unpack and inspect the control valve

Check the control valve when it is received at the customer facility.

Procedure

1. Remove the control valve from the shipping container.
2. Inspect the control valve for damage.
3. See Installation procedure.

3.2 Store the control valve

3.2.1 Rust inhibitor

Apply light oil or rust inhibitor on surfaces that are in contact with the environment.

3.2.2 Pack the control valve

Procedure

1. Use stretch wrap (not adhesive) to attach the correct size flange cover to the valve end flanges. This protects the unpainted surfaces of the flange sealing.
2. A flush contact between the flange cover and the flange sealing face is important.

3.2.3 Storage conditions

Store the control valve in a safe area to avoid damage.



WARNING

CRUSHING HAZARD

During installation or removal of a control valve, always place the unit on a stable platform or surface that supports its assembled weight.

Failure to comply may allow the control valve to roll, resulting in death, serious injury or equipment damage.

Table 3-1: Control valve storage conditions

Parameter type	Description
Storage environment conditions	For long term storage, it is recommended that the complete control valve assembly be stored under cover in a controlled environmental atmosphere in the original packaging. The storage temperature limits are: 20 °C to 60 °C (68 °F to 140 °F) .
Shelf life for elastomers	Inspect O-rings for wear or damage during disassembly of the cover and right before assembling the unit. Replace damaged elastomer. Viton® has an unlimited shelf life.
Inspect stored equipment	Examine the internal surfaces and flange faces of the control valve at least once every three months. Repack the control valve as originally received.
Labels and nameplates	Do not remove nameplates or labels. Doing so will void the control valve warranty.
Stacking conditions	When stacking equipment, follow all the safety standards taking into account the type of box used, the maximum height of the equipment, the maximum number of boxes stacked, etc.

4 Prepare the control valve for use

4.1 Lifting conditions

! WARNING
CRUSHING HAZARD

During installation or removal of a control valve, always place the unit on a stable platform or surface that supports its assembled weight.

Failure to comply may allow the control valve to roll, resulting in death, serious injury or equipment damage.

! WARNING
LIFTING HAZARD

The lifting instructions are for installation and removal of a Daniel control valve only and do not address lifting the control valve while it is attached or bolted to piping.

Failure to follow these instructions may result in death, serious injury or equipment damage.

! CAUTION
FORKLIFT HAZARD

Do not insert the forks of a forklift into the bore when moving the control valve.

Inserting the forks may cause the meter to become unstable, resulting in serious injury or equipment damage.

Table 4-1: Lifting and installation conditions

Conditions	Description
Ventilation and lightning	Install the control valve in a well lit and ventilated location, not less than one meter (approximately three feet) from source of ignition or source of heat which might damage the unit.
Surface considerations	Stable surface.
Soil/floor loadings and product/piping support	Follow local procedures that meet the standards for soil/floor loading and product/piping support.

4.2 Lifting requirements for personnel

4.2.1 Safety precautions using appropriately rated lifting slings

 **WARNING**

LIFTING HAZARD

The lifting instructions are for installation and removal of a Daniel control valve only and do not address lifting the control valve while it is attached or bolted to piping.

Failure to follow these instructions may result in death, serious injury or equipment damage.

- Only personnel properly trained in the safe practices of rigging and lifting should lift valves.
- Prior to use, visually inspect the slings for any signs of abrasion or other damage. Refer to the sling manufacturer for inspection procedures specific to the sling you are using.
- Never attempt to lift the valve by wrapping slings around the visual indicator, position indicator pilots, needle valves, accessories or tubing.
- Never attempt to lift the valve using only one sling around the valve. Always use two slings wrapped around each end of the body as shown below. Use a choker style sling with a spreader bar.

Figure 4-1: Correct sling attachment

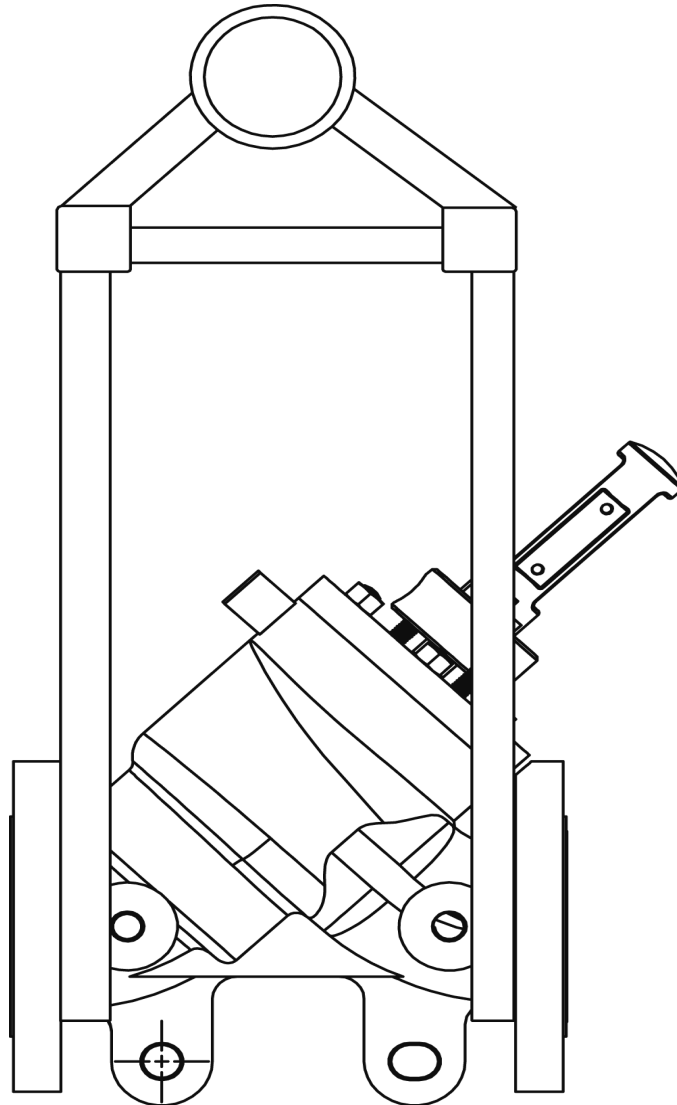

- Only use slings with ratings that exceed the weight to be lifted. Reference all safety standards for safety factors that must be included when calculating the load rating.

**⚠ CAUTION
SLING HAZARD**

Never allow the slings to come in contact with the visual indicator, position indicator, pilots, needle valves, accessories or tubing. Use a spreader bar on the sling to prevent contact.

Failure to comply may cause equipment damage.

- Never apply shock loads to the valve. Always lift the control valve gradually. If shock loading occurs, inspect the slings per manufacturer's procedures before reuse.



WARNING

EQUIPMENT HANDLING AND OPERATING HAZARD

Wear personal protective equipment appropriate to the situation when working with the control valve. Adhere to all safety standards and best practices for operating the equipment.

Failure to comply may result in death or serious injury.

4.3 Configure the control valve

The factory configures Daniel control valve internal components. Inspect the internal components before installation.

4.3.1 Orientation and position of the control valve

Flow direction

NOTICE

Comply with local government regulations and company requirements.

NOTICE

Flush lines to remove welding bead, pipe scale, etc.

NOTICE

Install the valve in a horizontal line with the cylinder head at the top.

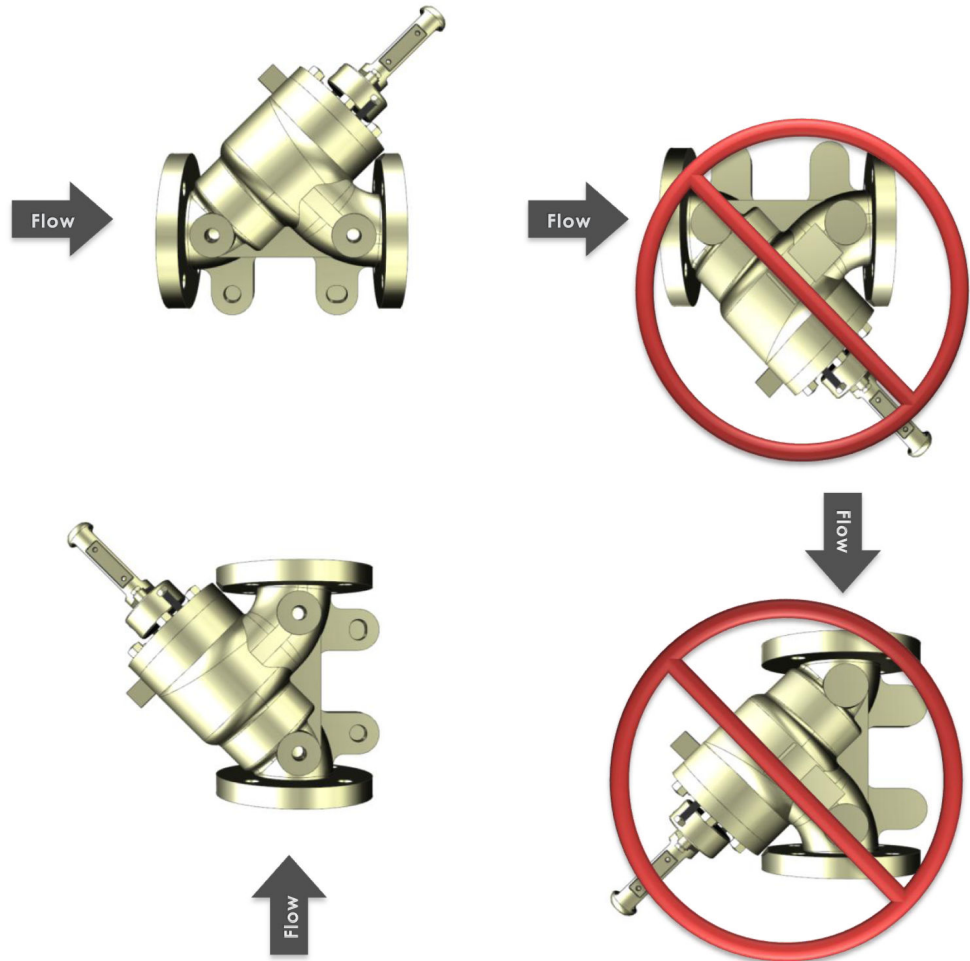
Figure 4-2: Control valve flow direction

⚠ WARNING
EQUIPMENT HAZARD
 Never use this equipment for any purpose other than its intended use.
 Failure to comply may result in death, serious personal injury and/or property damage.

4.3.2 Piping recommendations

NOTICE
 When installing the control valve, ensure that the bolts conform to the requirements of ASME B16.5 paragraph 5.3 and to the material requirements of ASME B16.5 Table 1B. Gaskets must conform to the requirements of ASME B16.20.

The design of the control valve has not been assessed for the effects of traffic, wind or earthquake loading.

Important

Ensure that piping or other attachments connected to the control valve are not under stress.

Important

Provide fire prevention measures and equipment per local regulations.

5 Installation prerequisites

5.1 Pre-start checks

Ensure that the pipeline is completely free of all foreign material before installing the valve. The design of the control valve has not been assessed for the effects of traffic, wind or earthquake loading. Provide fire prevention measures and equipment per local regulations.

5.2 Torque information

NOTICE

When installing the control valve, ensure that the bolts conform to the requirements of ASME B16.5 paragraph 5.3 and to the material requirements of ASME B16.5 Table 1B. Gaskets must conform to the requirements of ASME B16.20.

Tightening procedure:

1. Lubricate the nuts and bolts.
 2. Hand-tighten until the nuts and bolts are snug against the flanges.
 3. Use the minimum pressure setting on an air wrench.
 4. Use the correct tightening sequence for the bolt flanges.
 5. Follow your company's internal flange installation procedures.
-

Important

Ensure that piping or other attachments connected to the control valve are not under stress.

Important

Provide fire prevention measures and equipment per local regulations.

Flanges with 4 and 8 bolts

- First round - 30% of final torque (flange sequential order)
- Second round- 60% of final torque (flange sequential order)
- Third round - 100% of final torque (flange sequential order)
- One final time - clockwise or counter clockwise sequentially around the flange

Flanges with 12 or more bolts

- First round - 20% of final torque (flange sequential order)
- Second round - 40% of final torque (flange sequential order)
- Third round - 80% of final torque (flange sequential order)
- Fourth round - 100% of final torque (sequential order)

- One final time - clockwise or counter clockwise sequentially around the flange

5.3 Torque values (flanges)

Table 5-1: Reference torque values for Daniel Control Valve (ft-lb) flange connections

Nominal pipe size (NPS)	ANSI class 150	ANSI class 300
2	90	90
3	90	160
4	90	160
6	160	160
8	160	250

5.4 Torque pattern sequences

Table 5-2: Reference to torque pattern sequences

Nominal pipe size (NPS)	ANSI class 150	ANSI class 300
2	1-3-2-4	1-5-3-7 2-6-4-8
3	1-3-2-4	1-5-3-7 2-6-4-8
4	1-5-3-7 2-6-4-8	1-5-3-7 2-6-4-8
6	1-5-3-7 2-6-4-8	1-7-4-10 2-8-5-11 3-9-6-12
8	1-5-3-7 2-6-4-8	1-7-4-10 2-8-5-11 3-9-6-12

The position of the number 1 screw determines the position of the clockwise rotation of the subsequent screws.

5.5 Tools required for control valve installation

Flange installation tools

Follow all best practice procedures when installing or removing flanges.

Control valve components

The control valve does not have pre-installation requirements. If installation is required for maintenance purposes, use the following tools:

- Socket wrench
- Adjustable wrench
- T-handle or extended Allen wrench
- Arbor press (may be needed for 4- and 6-inch valves)
- Retaining ring pliers

6 Installation procedure

6.1 External components assembly

Install the external components (e.g., flanges) onto the pipeline.

The control valve is assembled at the factory. The components do not need to be uninstalled or reinstalled unless maintenance is required.

 **CAUTION**
SURFACE TEMPERATURE HAZARD

The control valve body and piping may be extremely hot or cold.

Wear personal protective equipment appropriate to the situation when working with the control valve. Adhere to your company's safety standards and practices.

Failure to comply may cause serious injury.

6.1.1 Fasteners

The property class of the fastener is in accordance with ASME B16.5.

Stud bolt and nut types

All fasteners (nuts and studs) used in assembling Daniel control valves are made of one of the materials listed in the table below.

Table 6-1: Bolt material selection

Bolt material selection	Description
ASTM SA 193 Grade B7 <63.5 mm (<2.5 in.)	High strength low alloy steel
ASTM SA 193 Grade B7M <63.5 mm (<2.5 in.)	Controlled strength low alloy steel
ASTM SA 320 Grade L7 <63.5 mm (<2.5 in.)	High strength low alloy low temperature steel
ASTM SA 320 Grade L7M <63.5 mm (<2.5 in.)	Controlled hardness low temperature steel
ASTM SA 449 <25.4 mm (<1.0 in.)	Quenched and tempered steel
ASTM SA 453 Grade 660	High temperature stainless steel

Selection of stud bolts and nuts

- Select all fasteners (nuts and studs) used in a hydrostatic test according to the flange size and class listed in ASME B16.5.
- Use the shortest stud bolt that permits full engagement of the thread through the nut by hand-tightening.
- Use only clean, rust-free nuts and stud bolts.

Note

Ensure that once the nut is tightened two threads outside the nut are exposed. The only exception is when a flange requires hydraulic bolt tensioning. The manufacturer of the

hydraulic bolt tensioning equipment will specify number of exposed threads outside the nut.

- Do not use damaged or worn stud bolts or nuts.
- Do not use nuts or stud bolts that do not fit together correctly.
- Do not use nuts or stud bolts without grade or type identification.
- Do not mix nuts or stud bolts of different coatings. Different nut and stud bolt coatings require different torques to achieve the same bolt tension.
- Do not assemble nuts with the identification hard stamp against the back face of the flange

Stud bolt and nut storage

Remove each nut and bolt as a pair. Thread the matching nut back onto the bolt. Stack them in a fashion that will not cause thread damage.

Reuse of stud bolts and nuts

The reuse of threaded fasteners is permitted on Daniel control valves under the following conditions:

- Fasteners are clean, free of corrosion, paint, thread damage, cracks, teeth marks (caused by wrenches) or other signs of damage.
- Fasteners are not tightened to or beyond their yield strength.
- Fasteners have not lost their coating.

Compare the threads of a used stud bolt with the thread of a new stud bolt. Finger-tighten the nut over the entire thread length of the bolt.

7 Testing the product

7.1 Commission the control valve

After installation, commission the control valve to ensure that the equipment is working properly.

Procedure

1. Inspect all bolts used to secure the control valve in-line to ensure that proper mounting procedures have been followed and that flange connections are leak-free.
2. Evaluate the system setup to ensure that all components are in the correct operating sequence.
3. Evaluate the system setup to ensure that all components are in the correct sequence for accurate product measurement. Some components are isolation valves, strainers, flow straighteners, turbine meters, downstream sections, etc.

8 Operation parameters

8.1 Control valve normal operation

The most common application of the Daniel Model 788DVC Digital Control Valve is for truck loading of petroleum products. The valve may be used with a variety of flow meter types, including Daniel series 1200 Turbine Meters and Coriolis.

Table 8-1: Typical opening/closing speed

Line size inches	Typical dead time setting (seconds)	Recommended low flow set-point				Typical opening speed adjustment (turns open)	Typical opening time (shut-off to full open) seconds	Typical closing speed adjustment (turns open)	Typical closing time (full open to shut-off) seconds
		Turbine		PD meter					
		gpm	K-factor	gpm	K-factor				
2-3	0.015	100	50	100	100	0.25	5.0	0.75	2.0
4	0.015	150	25	150	25	0.25	5.0	0.75	2.0
6	0.030	150	25	150	25	0.75	5.0	1.25	2.0
8	0.030	150	25	150	25	0.75	5.0	1.25	2.0

8.2 Operation accessories

- Opening speed control: Device installed in the Y port of the valve to control opening speed
- Thermal relief: It is the pressure differential safety device use to eliminate excessive pressures caused by thermal expansion.
- Block or isolation valve for X, Y, Z ports
- Manual override: Device used to by-pass the pilot module
- Valve position indicator
- Limit switches: The sequential switches convert the mechanical motion of the batch controlling mechanism of the preset counter to electrical signals used to control the solenoid pilots of the control valve for low flow position-shut down and/or start-up.

It is recommended to ensure that both the line and the product are clean before the valve is installed. Small particles of foreign material usually will not effect the performance of the valve, although larger particles may damage the valve piston and its seat.

8.3 Operation overview

Operation of the Model 788DVC Digital Control Valve is based on a balanced piston principle.

When pressure on both sides of the main valve piston are equal, a spring (located on the top of the piston) acts as a differential force and closed the main valve piston. As pressure against the bottom of the piston increases and exceeds the pressure exerted against the top of the piston, plus the force of the spring, spring tension is overcome and the valve opens.

**CAUTION****EQUIPMENT DAMAGE**

Read the entire recommended procedure for all installation operations and maintenance procedures before attempting to install or disassemble the valve. Disassembly of this cylinder assembly is different from previous Daniel Control Valves and requires strict adherence to the procedures outlined in this manual.

Failure to read and comply with these procedures could result in damage to the equipment and compromise in the integrity of the operation.

9 Planned maintenance

9.1 Maintenance considerations

Read and understand all instructions and operating procedures before performing maintenance procedure, internal component inspection, or field requirement changes.

To ensure safe and accurate performance, only informed and trained personnel should install, operate, repair and maintain this product.

Follow the recommendations below before servicing the control valve:

1. Label all parts or place parts in labeled containers during disassembly.
2. Do not use metal clamping devices in direct contact with any control valve part or surface.

Important

All control valve adjustments were completed at the factory during liquid calibration and should not require field setup.

9.2 Tools required for mechanical components

Flange installation tools

Follow all best practice procedures when installing or removing flanges.

Control valve components

The control valve does not have pre-installation requirements. If installation is required for maintenance purposes, use the following tools:

- Socket wrench
- Adjustable wrench
- T-handle or extended Allen wrench
- Arbor press (may be needed for 4- and 6-inch valves)
- Retaining ring pliers

9.3 Disassemble/Assemble the control valve

Before removing the control valve from the system, the following precautions must be taken:

The meter must be cleaned completely inside the housing components and stored/shipped as it was received.

1. Label all parts or place parts in labeled containers during disassembly.
2. Do not use metal clamping devices in direct contact with any control valve part or surface.

The control valve must be cleaned completely inside the housing components and stored/shipped as it was received. Refer to Storage Preparations for cleaning instructions.

After the meter is shut down, refer to Cylinder disassembly (NPS 2-8) for the detailed disassembly procedure.

After the previous steps have taken place, assemble the control valve per the instructions in Mechanical assembly.

9.3.1 Cylinder disassembly (NPS 2-8)

Procedure

1. Remove the compression fitting and tubing from the port Y connection on the cylinder head.
2. Remove the nuts that secure the cylinder head to the valve body.
3. Alternately tighten the jack-out screws until the cylinder assembly is free to be lifted out of the valve body.
4. Lift the cylinder assembly by the cylinder head. Remove it from the valve body and set it in a vertical position with the cylinder head on top.
5. Before removing the screws, place the cylinder assembly in an arbor press to immobilize the cylinder head. This is to prevent sudden spring pressure from being released and causing injury or damage.



CAUTION

SPRING PRESSURE HAZARD

Follow the instructions in Step 5.

Failure to comply may cause release of spring pressure, resulting in serious injury or equipment damage.

6. Use an Allen wrench to remove the screws that secure the cylinder head to the cylinder, and then gradually release the arbor press to remove the cylinder head from the cylinder. Remove the indicator guard and the upper bearing first, if your valve has a position indicator.
7. Remove the valve spring, indicator stem, retaining ring, washer, and piston from the cylinder. Remove only the valve spring and the piston if your valve does not have a position indicator.
8. With the cylinder in a vertical position (ports located on the top part of the cylinder), place the piston, nose end up, into the recess between the cylinder and the seat ring. Use an arbor press to push the piston into the cylinder, thus freeing the seat ring from the cylinder.

Figure 9-1: Using the piston to remove the seat ring from the 150/300 lb cylinder

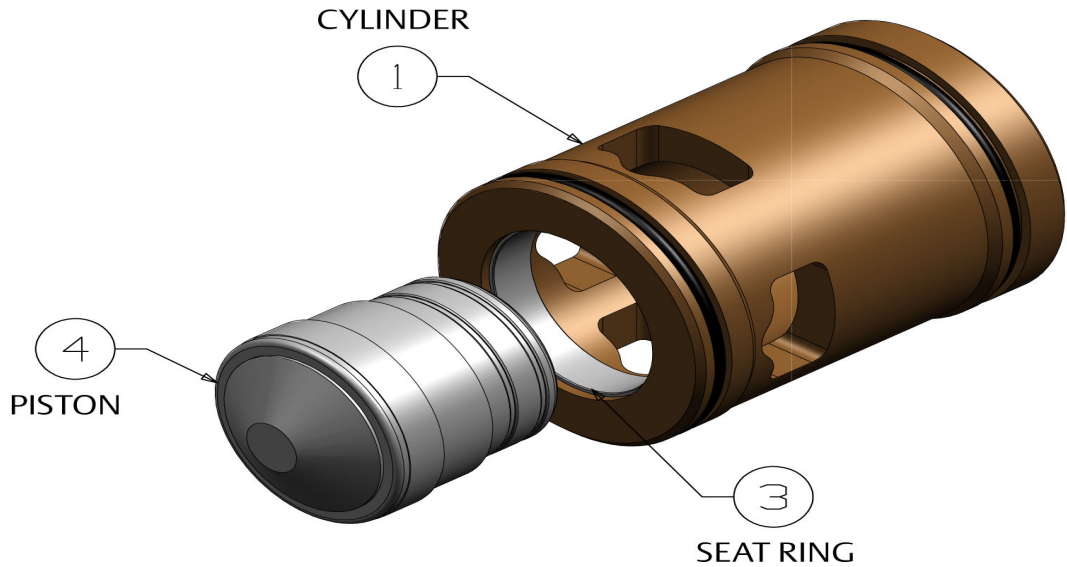

9. Turn the cylinder over with the ports on top when removing the high pressure seat ring. Remove the set screw from the seat ring. Turn the seat ring counterclockwise to remove the seat ring and then remove the O-ring from the cylinder.

9.3.2 Pilot disassembly (1710-1711)

Procedure

1. Remove electrical power from solenoid before disassembly.
2. Remove coil housing cover. Solenoid coil may now be removed.

NOTICE

The models 1710 and 1711 normally closed pilot have a retaining ring holding the coil in place which must be removed before coil can be removed.

3. Rotate the hex head nut below solenoid base assembly counterclockwise to separate solenoid base assembly from pilot body.
4. Remove cage assembly, consisting of plunger, valve cage and poppet shaft and disassemble as indicated by drawing.
5. Remove fitting and manual operator stem from bottom of pilot.
6. Remove valve seat.
7. Remove and inspect all O-rings.

⚠ CAUTION
EQUIPMENT HAZARD

Observe all precautionary signs posted on the equipment.
Failure to comply may result in injury to personnel or cause damage to the equipment.

⚠ CAUTION
BENT SHAFT HAZARD

Be careful to avoid bending the shaft when using the punch.
The shaft can be easily bent when using the punch incorrectly.
Failure to comply may result in injury to personnel or cause damage to equipment.

9.4 Mechanical assembly

9.4.1 Valve torque specifications

Table 9-1: Valve cylinder head to body (stud-nut) torque specifications

Valve size (in)	Flange rating (lbs)	Num. bolts	Min. torque (lbs/ft)
2	150	6	6
	300	6	15
3	150	6	15
	300	6	40
4	150	8	13
	300	8	35
6	150	8	18
	300	8	46
8	150	10	51
	300	10	132

Table 9-2: Valve cylinder head to cylinder (socket head screws) torque specifications

NPS	Class	Socket head screw size	Torque (ft-lb)
2	150	1/4"-20	5
2	300	1/4"-20	5
3	150	1/4"-20	5
3	300	1/4"-20	5

Table 9-2: Valve cylinder head to cylinder (socket head screws) torque specifications (continued)

NPS	Class	Socket head screw size	Torque (ft-lb)
4	150	1/4"-20	5
4	300	1/4"-20	5
6	150	1/4"-20	5
6	300	1/4"-20	5
8	150	5/16"-18	11
8	300	5/16"-18	11

9.4.2 Standard cylinder reassembly

Reassembly of a control valve without a position indicator

Procedure

1. Place the cylinder in an upright position with the ports on the bottom. Lubricate the inside of the cylinder wall with a suitable lubricant.
2. Insert the O-ring into the groove inside the bottom of the cylinder. This will require some effort.
3. Insert the seat ring into the cylinder; placing it on top of the O-ring.
4. Using the piston as your tool, place it nose end down into the cylinder on top of the seat ring. Using a hammer handle or similar device, press down on the piston to force the seat ring into position against the lip in the cylinder.
5. Remove the piston from the cylinder.
6. With the piston in a vertical position, nose end down, place the O-ring into the groove on the piston. (If the valve is a high-pressure model, the piston will require PTFE backup rings on either side of the O-ring.)
7. Place the indicator stem retaining ring into the counter bore of the piston. Place the washer on top of the indicator stem retaining ring. Using retaining ring pliers, place the retaining ring on top of the washer.
8. Insert the piston into the cylinder, nose end down.
9. Insert the spring into the piston.
10. Turn the jack-out screws in the cylinder head to their original position.
11. Place the O-ring into the groove in the cylinder head.
12. Place the cylinder head on top of the spring, and use an arbor press against the top of the cylinder head to press the spring into the cylinder.

⚠ CAUTION**SPRING PRESSURE HAZARD**

Follow the instructions in Step 12.

Failure to comply may cause force to release the spring, resulting in serious injury or equipment damage.

13. Align the holes in the cylinder head with the mating holes in the cylinder and insert the screws into the holes in the cylinder head. Tighten the screws using an Allen wrench.
14. Remove the cylinder assembly from the arbor press.
15. Place the O-rings into the grooves in the outside of the cylinder.
16. Holding the cylinder assembly by the cylinder head, place the cylinder assembly into the valve body, aligning the holes in the cylinder head with the mating studs in the valve body. Tighten the nuts that secure the cylinder head to the valve body. If your valve does not have a position indicator, you have finished reassembling your valve.
17. Reconnect tubing to center of the cylinder head.

Reassembly of a control valve with a visual position indicator

Procedure

1. Place the valve in a vertical position with the cylinder head up. Place the indicator stem into the center hole in the cylinder head, and press it into the retaining ring in the piston. You may have to wiggle the indicator stem a little to get it into position. When the indicator stem is in position, you will not be able to pull it out.
2. Place the magnets onto the indicator stem, and retain the magnets by placing the retaining ring on the indicator stem.
3. Coat the threads of the indicator adapter with pipe sealant, and place the indicator adapter over the indicator stem, and screw it into the cylinder head. The connection for the tubing should face upwards.
4. Place the ring magnet on the indicator adapter.
5. Place the indicator housing over the indicator adapter, and secure it with the indicator top and screw.

Reassembly of a control valve with a microswitch-type position indicator

Procedure

1. Place the valve in a vertical position with the head up. Place the indicator stem into the center hole in the cylinder head, and press it into the retaining ring in the piston. You may have to wiggle the indicator stem a little to get it into position. When the indicator stem is in position, you will not be able to pull it out.
2. Install the indicator adaptor onto the cylinder head by turning the indicator guard clockwise. Stack the O-ring, seat retainer, the O-ring retainer, O-ring in the upper bearing, and place them onto the indicator stem.

3. Install the indicator guard on the indicator adaptor and secure it with the lockwashers and screws. Replace the two jack-out screws.

9.4.3 AP cylinder reassembly

Procedure

1. Protect the cup-seals against damage or distortion of any kind.
2. Install cup-seals with the closed ends facing “in”.
3. Cup-seal installation:
 - Place the inside edge of the bottom seal in the deep recess of the piston body (below the seal’s resting position) and carefully pull seal into position. Adjust cup-seal position into its proper location.
 - Ensure that the closed ends of the top cup-seal face “in” (back-to-back).

Retrofit a control valve

Applications requiring aggressive products need control valve modification. Use the following specific valve retrofitting procedure for these petroleum blending operations.

Upgrade existing AP units supplied prior to September, 1992

Three O-rings are supplied as a separate kit to upgrade existing valves, which have the original AP option (received prior to September 1992).

Procedure

1. Follow the procedures described in Disassemble/Assemble the control valve for general disassembly and AP cylinder reassembly for aggressive products cylinder reassembly.
2. Replace O-rings as required.
3. Complete the cylinder assembly by installing the piston and all the component parts through the top of the cylinder housing.

Important

Do not attempt to install the piston through the seat area. This will destroy the spring-loaded Teflon cup-seals.

4. For ease of installation, secure cylinder assembly to cylinder heads using hand pressure or arbor press.

WARNING DISASSEMBLY HAZARD

When performing any disassembly procedure caution is required as the cylinder head is bolted to a spring loaded cylinder assembly. Service should only be performed by trained and qualified service personnel.

Failure to follow these instructions could result in death, serious injury or damage to the equipment.

5. Lower the "new" cylinder assembly and cylinder head into the valve body. Align the bolt holes in the cylinder head with the studs in the main valve body.
6. Fasten the cylinder head into position using retaining nuts. Tighten nuts, alternating to opposite sides, to assure a uniform seat.
7. Return all tubing and/or valve accessories to their original position.

9.4.4 Pilot reassembly

Procedure

1. Apply oil or grease to all O-rings to prevent cutting and to facilitate assembly.
2. Reassemble by reversing disassembly order. Be careful not to cut O-rings when assembling parts and assemblies.

Important

This pilot was designed without corrosion allowance. Periodically inspect the valve's metal parts for corrosion and erosion.

Inspect the seals and O-rings for wear and chemical deterioration.

Important

Ensure that piping or other attachments connected to the control valve are not under stress.

Important

Provide fire prevention measures and equipment per local regulations.

9.5 Planned maintenance tasks

Table 9-3: Planned maintenance tasks

Task	Recommended action
Inspect	Implement a periodic inspection program to ensure all parts are free from damage during its use due to process, ambient or other abnormal conditions. <ul style="list-style-type: none"> • Internal components: cylinder, piston, spring, cylinder head, seat retainer • Control valve body • Bolting
Clean	Use a non-toxic metal cleaning solvent. Do not use common petrochemical solvents like Benzene, Toluene or Xylene as they can pose potential health hazards.
Monitor corrosion / erosion / wear	A careful review of the control valve proving history, such as control valve factor control charts, can reveal potential problems bearing drag due to wear or increased internal cross-sectional area due to erosion.

Table 9-3: Planned maintenance tasks (continued)

Task	Recommended action
Part (seal) replacement	Visual inspection of the O-rings is recommended once a year and replacement of the O-rings is recommended at least once every five years. Follow internal procedures for part replacement. Do not twist or overstretch the O-ring during assembly.
Corrosion monitoring	Daniel recommends visually inspecting the control valve for corrosion in the internal components at least once a year. Follow internal procedures for corrosion. The valve was designed without corrosion allowance. Periodically inspect the valve's metal parts for corrosion and erosion, and inspect the seals and O-rings for wear and chemical damage.
Lubricant information	High-viscosity silicone oil with a temperature range of -54° C to 204° C (-65° F to 400° F).
Proper lubrication procedure	Lubricate the entire surface of the O-ring before installation with a thin layer of high-viscosity silicone oil. Remove excess lubricant.

10 Corrective maintenance

10.1 Control valve troubleshooting

Use the table below to troubleshoot the control valve. Contact the nearest Flow Lifecycle Services center for assistance with repairs of Daniel products. It is important that servicing be performed by trained and qualified service personnel.

Table 10-1: Troubleshooting issues for 788 DVC Control Valves

Condition	Probable cause	Correction ⁽¹⁾
Valve will not open	Upstream valve is closed	Open upstream valve.
	Pump is not operating	Start pump and check for cavitation.
	Downstream valve is closed	Open downstream valve. (Check coupler on bottom loading units and internal valve in truck.)
	Insufficient pressure	Check pump. Check bypass and strainer located in line.
	Clogged strainer	Clean strainer.
	Swollen O-rings	Disassemble valve and replace O-rings. Check compatibility of O-rings with product.
	Pilot malfunction	Consult pilot manual (710-711 Control Valve pilot)
Valve opens too slowly	Valve inlet pressure below normal	Check strainer and pump for obstruction.
	Swollen O-rings	Disassemble valve and replace O-rings. Check compatibility of O-rings with product.
	Check "X" port sensitivity control needle valve position (maybe closed too much)	Open sensitivity control needle valve.
	Pilot malfunction	Consult pilot manual (710-711 Control Valve pilot)
Valve will not close off tightly	Bent indicator stem	Replace indicator.
	Foreign material in main valve piston seat	Disassemble valve and inspect piston.
	Swollen O-rings	Disassemble valve and replace O-rings. Check compatibility of O-rings with product.
	Piston or seat O-ring cut or defective	Disassemble valve and replace if necessary.

Table 10-1: Troubleshooting issues for 788 DVC Control Valves (continued)

Condition	Probable cause	Correction ⁽¹⁾
	Pilot malfunction	Consult pilot manual (710-711 Control Valve pilot)

(1) Refer to *Disassemble/Assemble the control valve*.

10.2 Verify the return to operational condition

Once corrective maintenance has taken place, verify that the control valve is working properly by following the steps below.

Procedure

1. Inspect all bolts used to secure the control valve in-line to ensure that proper mounting procedures have been followed and that flange connections are leak-free.
2. Evaluate the system setup to ensure that all components are in the correct operating sequence.
3. Evaluate the system setup to ensure that all components are in the correct sequence for accurate product measurement. Some components are isolation valves, strainers, flow straighteners, turbine meters, downstream sections, etc.

11 Spare parts

11.1 Recommended spare parts

Table 11-1: Recommended spare parts

Description	NPS	Class	Elastomer	Without Indicator	With Position Indicator	With Visual Indicator
Valve Assembly O-ring kit	2	150-300	Buna-N	W520055-6 90	W520155-6 90	W520555-6 90
			EPR	W520055-6 97	W520155-6 97	W520555-6 97
			FFKM	W520055-6 95	W520155-6 95	W520555-6 95
			Aggressive Products	W520055-6 96	W520155-6 96	W520555-6 96
			CR	W520055-6 93	W520155-6 93	W520555-6 93
			FKM	W520055-6 92	W520155-6 92	W520555-6 92
			FKM GFLT	W520055-6 9G	W520155-6 9G	W520555-6 9G
			FKM V1289	W520055-6 9M	W520155-6 9M	W520555-6 9M
	3	150-300	Buna-N	W530055-6 90	W530155-6 90	W530555-6 90
			EPR	W530055-6 97	W530155-6 97	W530555-6 97
			FFKM	W530055-6 95	W530155-6 95	W530555-6 95
			Aggressive Products	W530055-6 96	W530155-6 96	W530555-6 96
			CR	W530055-6 93	W530155-6 93	W530555-6 93
			FKM	W530055-6 92	W530155-6 92	W530555-6 92
			FKM GFLT	W530055-6 9G	W530155-6 9G	W530555-6 9G
FKM V1289	W530055-6 9M	W530155-6 9M	W530555-6 9M			
4	150-300	Buna-N	W540055-6 90	W540155-6 90	W540555-6 90	

Table 11-1: Recommended spare parts (continued)

Description	NPS	Class	Elastomer	Without Indicator	With Position Indicator	With Visual Indicator
			EPR	W540055-6 97	W540155-6 97	W540555-6 97
			FFKM	W540055-6 95	W540155-6 95	W540555-6 95
			Aggressive Products	W540055-6 96	W540155-6 96	W540555-6 96
			CR	W540055-6 93	W540155-6 93	W540555-6 93
			FKM	W540055-6 92	W540155-6 92	W540555-6 92
			FKM GFLT	W540055-6 9G	W540155-6 9G	W540555-6 9G
			FKM V1289	W540055-6 9M	W540155-6 9M	W540555-6 9M
6	150-300	Buna-N	W560055-6 90	W560155-6 90	W560555-6 90	
		EPR	W560055-6 97	W560155-6 97	W560555-6 97	
		FFKM	W560055-6 95	W560155-6 95	W560555-6 95	
		Aggressive Products	W560055-6 96	W560155-6 96	W560555-6 96	
		CR	W560055-6 93	W560155-6 93	W560555-6 93	
		FKM	W560055-6 92	W560155-6 92	W560555-6 92	
		FKM GFLT	W560055-6 9G	W560155-6 9G	W560555-6 9G	
8	150-300	Buna-N	W580055-6 90	W580055-6 90	NA	
		EPR	W580055-6 97	W580055-6 97	NA	
		FFKM	W580055-6 95	W580055-6 95	NA	
		Aggressive Products	W580055-6 96	W580055-6 96	NA	
		CR	W580055-6 93	W580055-6 93	NA	

Table 11-1: Recommended spare parts (continued)

Description	NPS	Class	Elastomer	Without Indicator	With Position Indicator	With Visual Indicator
			FKM	W580055-6 92	W580055-6 92	NA
			FKM GFLT	W580055-6 9G	W580055-6 9G	NA
			FKM V1289	W580055-6 9M	W580055-6 9M	NA

Table 11-2: Spare parts for pilots

Description	2 inch	3 inch	4 inch	6 inch	8 inch	Qty
Solenoid (N.C.) 110/50, 120/60 220/50, 240/60	456800-612 456800-621	456800-612 456800-621	456800-612 456800-621	456800-612 456800-621	456800-612 456800-621	1
Solenoid (N.O.) 110/50, 120/60 220/50, 240/60	456815-012 456815-022	456815-012 456815-022	456815-012 456815-022	456815-012 456815-022	456815-012 456815-022	1
Needle valve	460385-522	460385-522	460385-522	460385-522	460385-522	
Strainer assembly	530245	530245	530245	530245	530245	2

Order spare parts

Contact Flow Lifecycle Services for Daniel products and provide the following information when ordering parts:

- Daniel control valve serial number
- Part number
- Part description
- Quantity

12 Decommission

12.1 Shut down the control valve

Follow the steps below to shut down and disassemble the control valve for storage or shipment.

 **WARNING**
PRESSURE HAZARD

The control valve is subject to pressurized fluids. Isolate the control valve upstream and downstream.

Always depressurize the control valve before disassembly.

Failure to comply may cause high pressure fluids to leak, resulting in death or serious injury.

Procedure

1. Ensure that the valve is free of contaminants.
2. Drain the valve of liquids.
3. Clean the valve components.
4. Label all parts or place parts in labeled containers during disassembly.
5. Do not use metal clamping devices in direct contact with control valve parts or surfaces.

12.2 Shipment of the control valve

Refer to Flow Lifecycle Services for Daniel products information in the preface of this document.

A Needle valve

A.1 Disassembly and assembly

Figure A-1: Needle valve

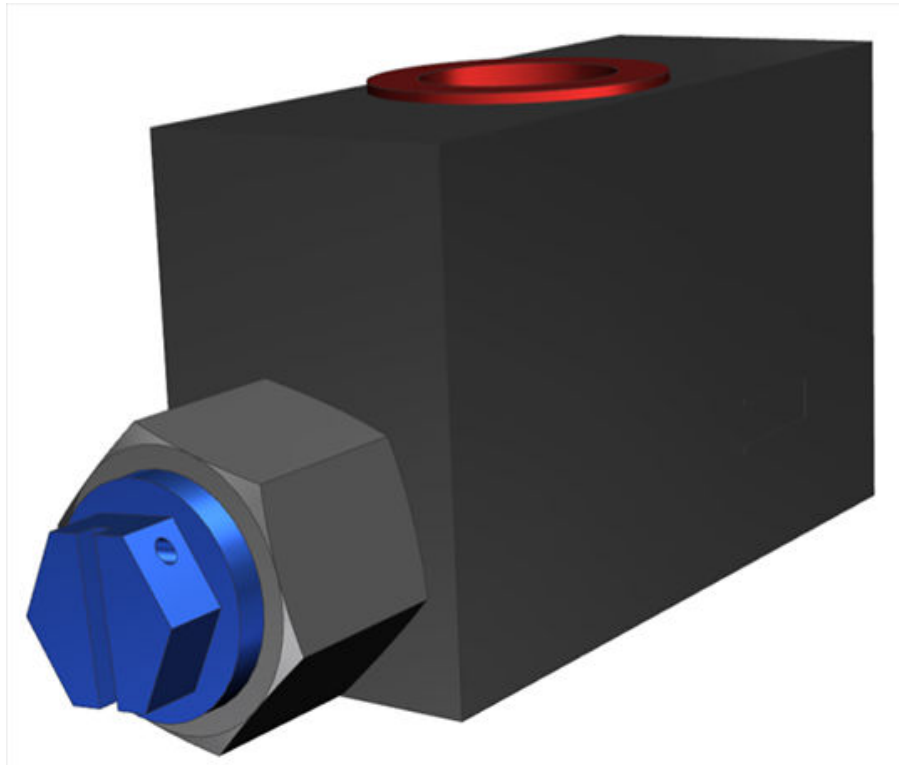

Procedure

1. Isolate and remove all pressure and drain before maintenance.
2. All parts associated with the adjustment stem are removable when the retainer is removed. Remove the adjustment stem by turning it counterclockwise.
3. For pilots used on crude oil, gasoline, diesel fuel or other general liquid hydrocarbon service, apply a light oil or general purpose grease to all O-rings to prevent cutting and to facilitate assembly. Use a light oil only for Butane and Propane service.

Tools required:

- Retaining ring pliers
- Ratchet wrench
- Pin removal tool
- Needle nose pliers

A.2 Needle valve

Figure A-2: Needle valve

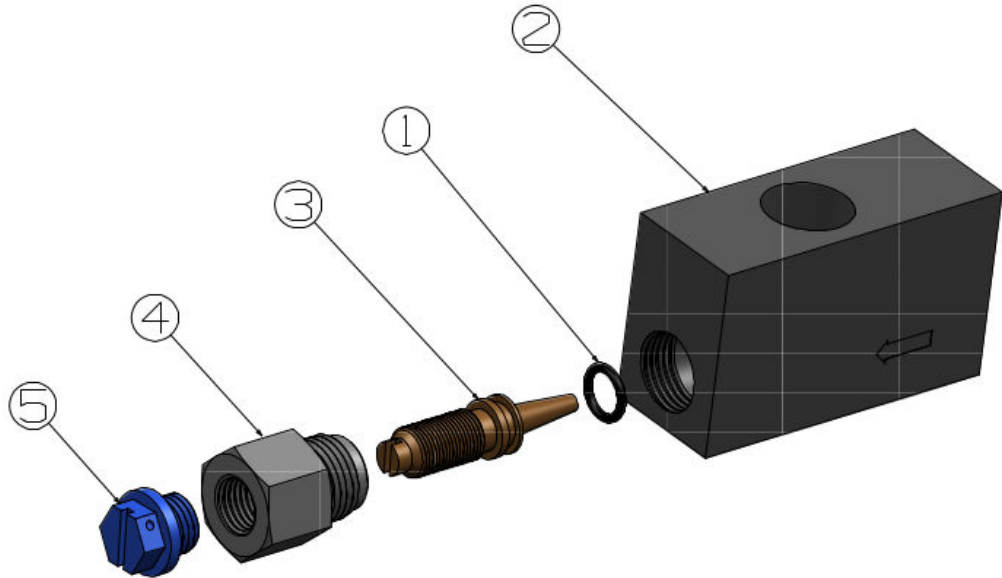

Table A-1: Part description for needle valve

Item Number	Description	Part Number	Quantity
1	O-ring, NBR	152067	1
	O-ring, EPR	152067-005	1
	O-ring, FFKM	152067-075	1
	O-ring, NBR (Low-swell)	152067-120	1
	O-ring, CR	152067-116	1
	O-ring, FKM	152067-022	1
	O-ring, FKM GFLT	152067-027	1
	O-ring, FKM V1289	152067-029	1
	2	NPS 2-6 Pilot Body (Carbon Steel)	460386-500M
NPS 2-6 Pilot Body (303 Stainless Steel)		460386-600M	1
NPS 8 Pilot Body (Carbon Steel)		460386-551M	1
NPS 8 Pilot Body (303 Stainless Steel)		460386-651M	1
3	NPS 2-6 Adjustment Stem	460683M	1
	NPS 8 Adjustment Stem	460683-001M	1

Table A-1: Part description for needle valve (continued)

Item Number	Description	Part Number	Quantity
4	Retainer	460684M	1
5	Cap	460686	1

A.3 Order spare parts

Provide the following information when ordering parts:

- Daniel valve serial number
- Part number
- Part description
- Quantity

With over 90 years of experience, Daniel is the only manufacturer that has the knowledge and experience to engineer and offer superior products that are trusted to provide the most reliable and accurate measurements in the global oil and gas industry.

Contact Us

Email: Sales@Daniel.com

Phone: +1(346) 509-3700



www.Daniel.com