

MRT 97-M Totalizer



CONTENTS

Specifications	1
Battery Installation and Replacement	2
Dimensions	2
Theory of Operation	3
Wiring	3
Typical Applications	3
Definitions	4
Programming Flowchart	8
Operation	10
Error Messages	11
Analog Output Calibration	11
Ordering Information	11

SPECIFICATIONS

Description

Featuring 5 digits of rate and 8 digits of total, the MRT 97-M is a battery or loop powered indicator capable of accepting magnetic pickup, DC pulse and switch closure inputs from pulse producing flowmeters. The unit can be ordered with an optional 4-20mA output. The MRT 97-M uses the 4-20mA loop to provide power when this output is used.

Specifications

Power:

BATTERY POWERED

Supplied standard with 2 C size Lithium batteries.

LOOP POWERED

Voltage: 8.5 to 30 VDC

Supplied standard with 2 C size lithium batteries

Protection: Reverse Polarity Protection on Current Loop

Burden: 8.5V maximum

BATTERY LIFE EXPECTANCY:

Expected Years of Operation for MRT 97-M of various powering options at equipment duty cycles

MODEL	RUN TIME			
	Idle	2hrs/day	8hrs/day	24hrs/day
MRT 97-M	10yrs	10yrs	10yrs	9.1yrs
Battery Powered				
MRT 97-M	Indefinite operation when loop powered			
Loop Powered				

NOTE: Battery shelf life is rated at 10 years by manufacturer Life expectancy based on rated battery capacity at 20°C
The above table is shown with pulse output inactive. Use of pulse output shortens battery life.
Example: A pulse output of 0.06 sec. duration, once per second, would derate the battery life by 20%.

DISPLAY:

Rate Display: (selectable decimal)
5 Digits (99999), 0.35" High, Display updates once per second with battery power, 8X per second with DC or Loop power
Rate Descriptors: /MIN, /HR, /DAY
Min. Input Frequency: 0.01 Hz to 10 Hz (selectable delay of 0.1 to 99.9 seconds)*
Selectable Rate Display Damping
Totalizer Display: (selectable decimal)
8 Digits (99999999), 0.2" High
Totalizer Descriptors: GAL, BBL, MCF, M3, "blank"
Warning Displays: Low battery warning

PULSE OUTPUT:

The pulse output advances with the least significant digit of the totalizer or decimal multiples there of (see Pulse scale divider).
Type: Isolated photomos relay
Max. voltage (off state): 30 VDC
Current (on state): 100mA
Pulse Duration: Selectable 0.5, 0.25, 0.125, 0.0625 seconds
Pulse Scale divider (Pulscale): User selectable, +1, +10, +100 or OFF
NOTE: Select OFF for max. battery life.

ACCURACY:

0.01% Reading, ±1 count
Temperature Drift: 50 ppm/°C Worst Case

ENVIRONMENTAL:

OPERATING TEMPERATURE
-4°F (-20°C) to +158°F (70°C)
Extended Temp: -22°F (-30°C) to +158°F (70°C)
HUMIDITY
0 - 90% Noncondensing

APPROVALS:

CE Compliant, CSA Listed, UL I.S. Available
Complies with the ATEX Directive 94/9/EC Ex d IIB T6

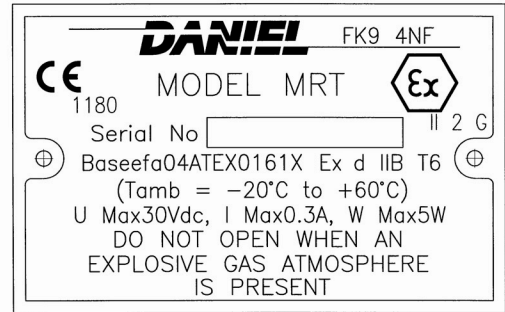

INPUTS:

MAGNETIC PICKUP INPUT

Frequency Range: 0 to 4500 Hz

Trigger Sensitivity: 10 mV p-p

Over Voltage Protected: ± 30 VDC

OPTO-ISOLATED DC PULSE INPUT

High (logic 1): 4-30 VDC

Low (logic 0): Less Than 1 VDC

Minimum Current: .5 mA

Hysteresis: 0.4 VDC

Frequency Range: 0 to 5 kHz

Min. Pulse Width: 0.1 msec

CONTACT CLOSURE INPUT (contact closure to common)

Internal Pullup Resistor: 100 KΩ to +3.6 VDC

High (logic 1): Open or 4-30 VDC

Low (logic 0): Less Than .5 VDC

Internal Switch Debounce Filter: 0 to 40 Hz

NOTE: Sustained contact closure will shorten battery life.

RESET INPUT (contact closure to common)

Internal Pullup Resistor: 100 KΩ to +3.6 VDC

High (logic 1): Open or 4-30 VDC

Low (logic 0): Less Than .5 VDC

Minimum On : 25 msec

NOTE: Sustained contact closure will shorten battery life.

K-FACTOR

Range: 0.001 to 99999999

Decimal Point Locations: XXXX.XXXX to XXXXXXXX

20 Point Linearization Option

This feature allows the user to enter 20 different frequencies with 20 different corresponding K-Factors to linearize non linear signals.

ANALOG OUTPUT:

Type: 4-20 mA follows rate display, Two wire hookup

Accuracy: 0.025% Full Scale at 20° C

Temperature Drift:

50 ppm/°C Typical

Reverse Polarity Protected

Update Rate: 8 times/second

NOTE: The MRT 97-M uses the 4-20 mA loop power as its primary power source when this option is used. The battery is still required for standby battery operation.

DATA STORAGE:

Setup Information: Stored in flash memory

Totalizer: Stored in battery backed RAM but can be saved to flash memory by operator for recall after battery change out.

* A large delay setting and internal math operations may delay the update rate.

BATTERY INSTALLATION and REPLACEMENT

Battery Installation:

All MRT97M models are shipped without the battery(ies) installed. This preserves battery life when the unit is not in service.

To install the battery, begin by locating the battery holder. This will require opening the enclosure cover and removing the MRT97M to expose the battery holder.

The plus terminal of the battery is marked with a (+) symbol stamped into the battery holder. Be sure to install the battery(ies) correctly.

Install battery(ies) to begin setup procedure. See Programming Flowchart to setup desired operating parameters.

Battery Replacement:

The MRT 97-M has a battery monitor feature which illuminates when the lithium battery voltage approaches its end of life. A descriptor, "BAT", illuminates when the battery voltage falls below this predetermined value. The low battery detector operates correctly with all power options.

The battery, or batteries, should be replaced within several weeks of the first occurrence of low battery warning, "BAT". Left unattended, the unit may become inaccurate, cease to operate or malfunction.

Before replacing the battery(ies), Press the ← (left arrow) key to save the totalizer. The display will show "ΣRUE EOEFL". This will save the current total value and the total will resume from this value when the new battery(ies) is(are) installed. **NOTE:** If the display starts to flash after the "ΣRUE EOEFL" message times out, press the "E" (enter) key. If the message "E FLASH" is displayed, then there was not enough power left to save the setup and totalizer to flash memory. At this point you must record the totalizer and setup information and re-enter the setup data after the new battery(ies) is(are) installed.

Install new battery(ies) as described above.



WARNING!

Do not open when an explosive atmosphere is present.

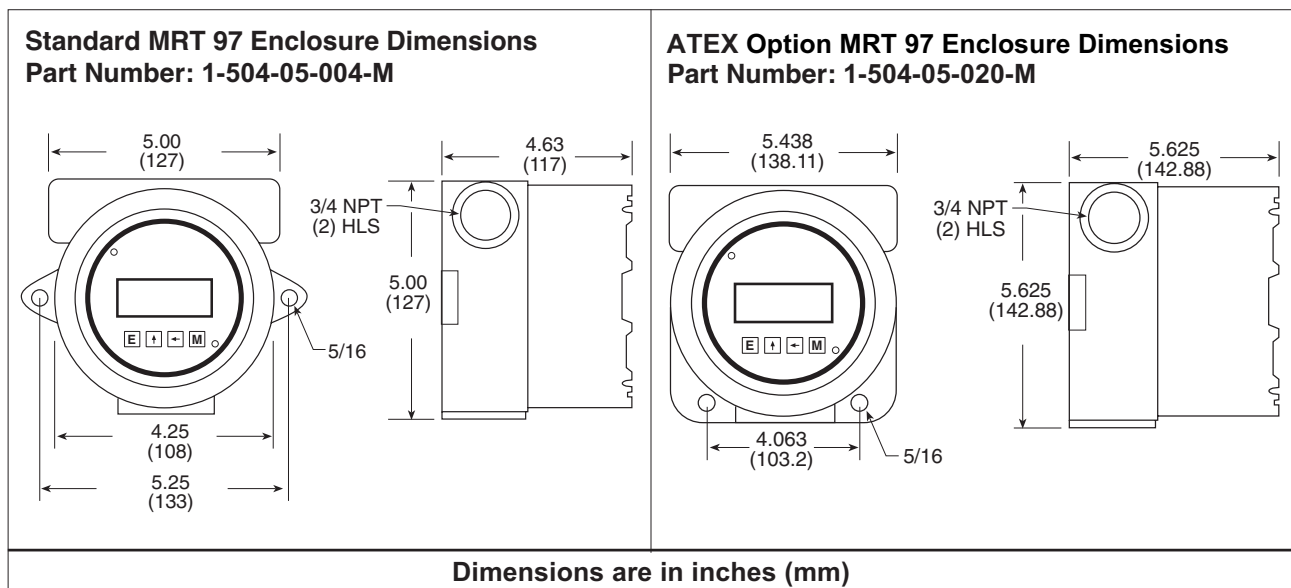

THEORY OF OPERATION

Flow rate equation:

$$\text{Flow Rate Indication} = \frac{\text{Input Frequency}}{\text{FAC}} \times \text{Time Scaler}$$

Where Time Scaler is equal to: 60 for rate per minute read out
3600 for rate per hour read out
86400 for rate per day read out

Flow total equation:

$$\text{Flow Total} = \frac{\text{Sum of Input Pulses}}{\text{FAC}}$$

20 Point Linearization Option:

A 20 point linearization table is used to construct a curve describing the relationship of K-Factor and input frequency. The measured input frequency is used to access the table. A linear interpolation of adjacent point pairs is used to arrive at the K-Factor at that input frequency. The flow rate and total are then computed based upon the K-Factor for that measurement sample.

NOTE: For best performance and resolution choose as many decimal places as possible in the K-Factor.

Example: Enter a K-Factor of 1 as 1.000.

WIRING

Several typical applications of the MRT 97-M are shown on the following page. Please observe that the various pulse inputs and power options may be intermixed in many ways to solve common applications. The isolated pulse output may be freely used so long as proper polarity is observed.

Caution: When 4-20 mA loop option is provided, the power wiring to the loop power option should always be to terminals (+) 12 and (-) 11. Accidental wiring to (+) 12 and (-) 6 should be avoided since excessive current flow may result.

Caution: The magnetic pickup input and contact closure input require isolated sensors for proper operation. Accidental connections to earth may result in erroneous operation of the analog output and/or excessive current flow.

Caution: Accidental connections from circuit common (3 or 6) to earth or terminal (11) may result in erroneous operation of the analog output and/or excessive current flow.

TYPICAL APPLICATIONS

4-20 mA OUTPUT CONFIGURATION

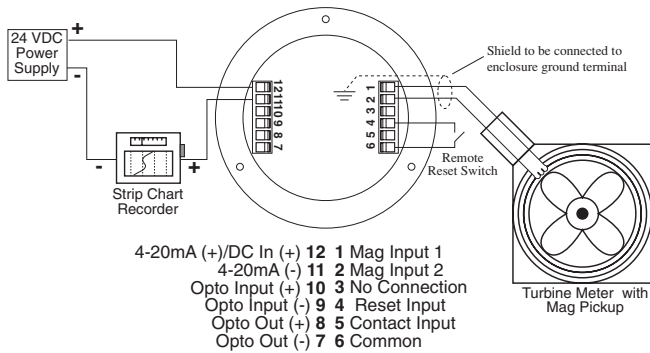

PULSE OUTPUT CONFIGURATION

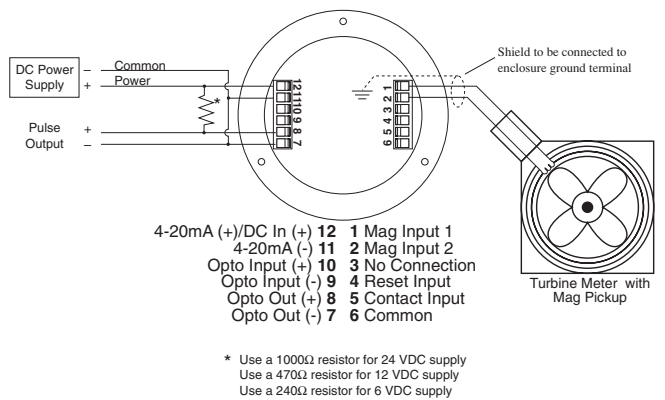

DC POWERED & PREAMP CONFIGURATION

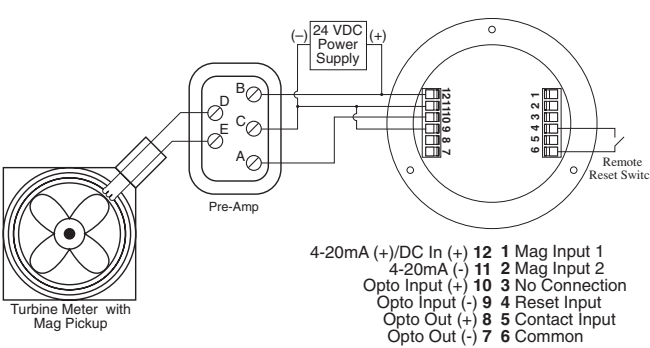

PULSE OUTPUT CONFIGURATION - PLC

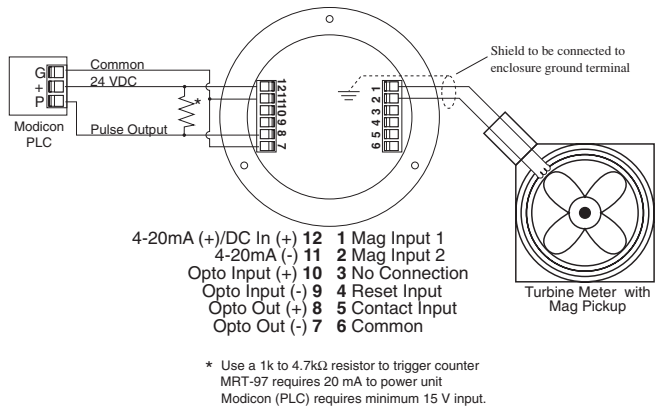

PULSE OUTPUT CONFIGURATION - RELAY

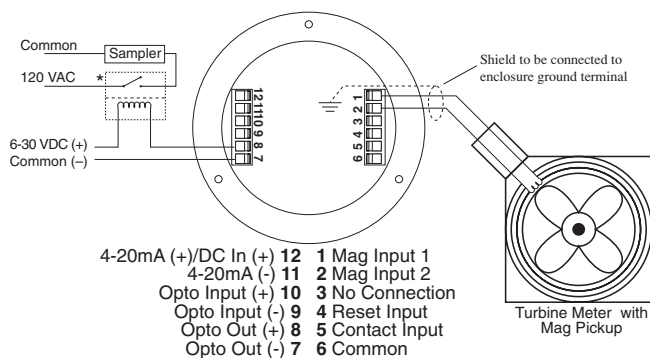

* Relay
 Potter Brumfield model: CNT-35-96 or equal

- 1) Current through MRT-97 should be limited to 100mA max. Solid state relay is suggested.
- 2) Pulse width may not be adequate to cycle the solenoid valve. A solid state relay with an adjustable delay release should be considered.

PULSE OUTPUT CONFIGURATION - TOTALIZER

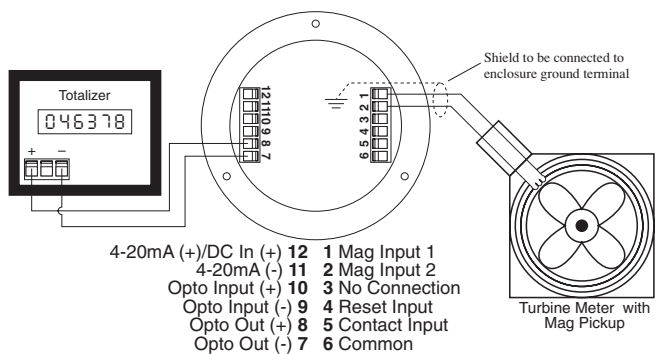

NOTE: 1) Connect (+) 8 from MRT-97 to (+) terminal of totalizer and (-) 7 from MRT-97 to (-) terminal of totalizer
 2) Scaling is done in the MRT-97

DEFINITIONS

SRUE ŁŁŁRL: (Save Total) Press the **E** key while the unit is running to save the total value. The display will show "SRUE ŁŁŁRL" for a few seconds. This is a very useful "scratch pad" to save and restore total when replacing the battery(ies)

ŁŁŁŁŁ: (enter code) This prompt will only appear if the panel lock is ON. Press the \uparrow key to increment each digit. Press the \leftarrow key to step to the next digit to the left. Press the **E** key to enter the 5 digit code. If the entered code is correct, the display will advance to the next menu prompt (CLr tot). If incorrect, the display will return to the run mode.

CLr ŁŁŁ: (clear total) Clears (resets) the totalizer. Press the **E** key to clear the total and return to the run mode. Press the **M** key to skip and advance to the next menu selection.

FŁŁŁ: (factor decimal) Sets the decimal location for the factor. This location is restricted to 3 places (99.999). The use of this decimal automatically limits the number of decimal locations allowable in the rate and total to acceptable ranges. Press the \leftarrow key to move the decimal. Press the **E** key to select the displayed decimal location.

NOTE: For best performance and resolution choose as many decimal places as possible in the K-Factor.
Example: Enter a K-Factor of 1 as 1.000.

FRL ŁŁŁŁŁ/ŁŁŁŁŁŁŁ: (factor type) This prompt will only appear if the unit is ordered with the 20 point linearization option. The **ŁŁŁŁŁ** linearization selection is recommended for flow meters whose K-factors change with different flow rates. This selection allows users to enter up to 20 different frequencies with 20 corresponding K-factors for different flow rates. The **ŁŁŁŁŁ** setting is used for flow meters whose output is linear over its' entire operating flow range. Press the \uparrow key to step to the desired choice. Press the **E** key to enter the displayed factor type.

ŁŁŁ / ŁŁŁ ŁŁŁ ŁŁŁŁ: (set 20 point?) This prompt allows the user to skip the 20 point setup routine. Select **ŁŁŁ** for initial setup or to change the present 20 point values. Select **ŁŁŁ** to skip and keep the existing values.

FRL : (factor) This prompt appears on all units with linear inputs. The Factor is the number of pulses per unit volume for the flow sensor. The pulses/unit volume is implied by the totalizer descriptor when a descriptor is used. The implied units for the Factor are then as follows:

GAL	pulses/gallon
BBL	pulses/BBL
MCF	pulses/MCF
M3	pulses/M3

Factors from 0.0001 to 99999999 may be used. A "0" value for the factor is not allowed and the unit will default to "1" in LSD if a "0" entry is attempted. The factor is displayed on the subsidiary (lower) display. Press the \uparrow key to increment each digit. Press the \leftarrow key to step to the next digit to the left. Press the **E** key to enter the displayed factor.

Fr # : (frequency for point #) This prompt will only appear when 20 point selected. It sets the frequency for each of the 20 points (#). Press the \uparrow key to increment each digit. Press the \leftarrow key to step to the next digit to the left. Press the **E** key to enter the desired frequency for point #.

FRL # : (factor for point #) This prompt will only appear when 20 point selected. It sets the factor for each of the 20 points (#). Press the \uparrow key to increment each digit. Press the \leftarrow key to step to the next digit to the left. Press the **E** key to enter the desired factor for point #.

NOTE: The display will advance to the next point (Fr#) after each entry of the Fr & Fac until all 20 points are complete. entering a 0 in the Fr or fac setting will advance the display to the next menu prompt (tdec).

DEFINITIONS (continued)

tDEC: (totalizer decimal) Sets the decimal location for the totalizer. The totalizer decimal is not a dummy decimal and will scale the totalizer display accordingly. (i.e. if the tdec is set in the tenths position (1234567.8), 100 will be displayed as 100.0). The location of the decimal point allows for greater resolution of both the totalizer display and the pulse output. The pulse output advances at a rate dependent on the least significant digit of the totalizer. The totalizer decimal location is restricted to a maximum of 4 places (1234.5678). However, the number of totalizer decimal locations allowable is reduced with each decimal place added to the factor decimal. Press the ← key to move the decimal. Press the **E** key to enter the displayed decimal location.

Note: The selection of the factor decimal point limits the available selections for the number of decimal points available for the totalizer. This is automatic. Enter your selection of the Factor's decimal point before entering the totalizer decimal point to assure the proper selection of the totalizer decimal point has been made.

tDESC: (totalizer descriptor) This allows you to illuminate one of the available descriptors on the display (GAL, BBL, MCF, M3, "blank"). Press the ↑ key to select the descriptor. Press the **E** key to enter the selected descriptor.

rSCALE: (ratemeter scaling) Sets the rate readout. Choose rate per day (dRY), hour (hr5) or minutes (min). The scale setting is shown on the main (upper) display. Press the ↑ key to step to the desired choice. Press the **E** key to enter the displayed scale setting.

Note: A rate descriptor corresponding to the above choice will be illuminated on the display.

rDECLOC: (ratemeter decimal location) Sets the decimal location for the ratemeter. The ratemeter decimal is not a dummy decimal and will scale the rate display accordingly. (i.e. if the r decloc is set in the tenths position (123.4), 100 will be displayed as 100.0). The ratemeter decimal location is restricted to a maximum of 4 places (.1234). However, the number of ratemeter decimal locations allowable is reduced with each decimal place added to the factor decimal. Press the ← key to move the decimal. Press the **E** key to enter the displayed decimal location.

Note: The flow rate indicator will flash "99999" if the computed flow rate exceeds the 99999 display capability of the indicator. Choose a new decimal point location to avoid this.

NOR # NORMALIZING FACTOR - Normalizes (averages) the data being received. Enter a value from 0 to 9.

Higher settings provide more normalizing (averaging) for a more stable display. Derived from the equation:

$$\frac{(\text{Old Data} \times \text{"NOR"} + \text{New Data})}{(\text{"NOR"} + 1)}$$

DELAY: (delay) Sets the amount of time (0.1 to 99.9 seconds) that the unit will "look" for valid input data. If pulses are not detected within this "window", the rate will display 0. The display will update once every second as long as the unit receives valid data within a second. Some internal mathematics may delay this update. Press the ↑ key to increment each digit. Press the ← key to step to the next digit to the left. Press the **E** key to enter the displayed delay value.

out Lo: (out low) Sets the low setting for the 4-20 mA analog output. Key in the low rate value at which the unit will output 4mA. Press the ↑ key to increment each digit. Press the ← key to step to the next digit to the left. Press the **E** key to enter the displayed out lo value.

out Hi: (out high) Sets the high setting for the 4-20 mA analog output. Key in the high rate value at which the unit will output 20 mA. Press the ↑ key to increment each digit. Press the ← key to step to the next digit to the left. Press the **E** key to enter the displayed out hi value.

DEFINITIONS (continued)

PULSE: (pulse out scaling) This allows the unit to output a pulse for each least significant total count divided by the selected divider. The pulse out can be divided by 1 (1), 10 (10), 100 (100), or turned off (OFF). With the divider set at 1, the unit will give a pulse out for every increment of the LSD displayed.

Note: For maximum battery life, turn the pulse output off when pulse output is not used.

Selecting the proper pulse output divider may be needed so that the pulse output does not exceed the maximum rate of the pulse output. If the pulse output pulses too quickly a flashing display will result. Pressing the "M" key will result in a display of an error message "E PULSE". Press the "E" key to return to the run mode.

PULSE: (pulse width) Sets the pulse width of the pulse output. Selections are: 0.5 (1Hz), 0.25 (2Hz), 0.125 (4Hz) or 0.0625 (8Hz). This menu item is skipped if PULSE is turned off.

LOCK: (lock code) Sets the 5 digit lock code to be entered when the unit prompts Enter Code. This allows the user to gain access to the menu when the unit is locked. Press the ↑ key to increment each digit. Press the ← key to step to the next digit to the left. Press the E key to enter the displayed code.

Record this number for later use!

LOCK CODE: _____

LOCK: (lock unit) Sets the panel lock ON or OFF. Press the ↑ key to select On or OFF. Press the E key to enter the displayed selection.

PROGRAMMING FLOWCHART

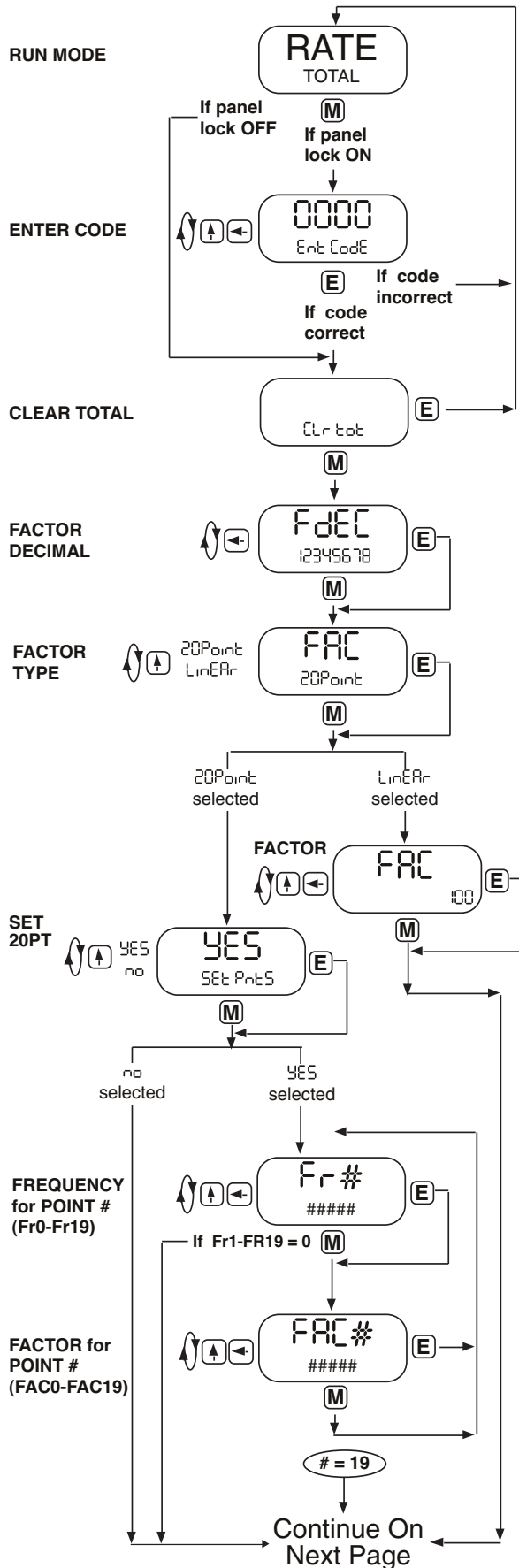

Press the **M** key to enter the programming menu.

If the panel lock is on, you must enter the 4 digit lock code to gain access to the menu.

Press the **↑** key to increment each individual digit of the code.

Press the **←** key to advance to the next digit.

Press the **E** key to enter the displayed code.

If the code is correct, display advances to "Clr Tot", if not, display returns to run mode

Press the **E** key to clear the totalizer and return to the programming menu.
Press the **M** key to skip and go to next menu item.

Press the **←** key to step the factor decimal to the desired location.

Press the **E** key to enter the displayed decimal location.

Press the **M** key to skip and keep the existing location

NOTE: For best performance and resolution choose as many decimal places as possible in the K-Factor. Example: Enter a K-Factor of 1 as 1.000.

Press the **↑** key to choose factor type (20Point or Linear).

Press the **E** key to enter the displayed factor type.

Press the **M** key to skip and keep the existing factor type.

The FAC prompt will only appear if Linear is selected or if the unit was ordered without the 20 point linearization option.

Press the **↑** key to increment each individual digit of the factor.

Press the **←** key to advance to the next digit.

Press the **E** key to enter the displayed factor.

Press the **M** key to skip and keep the existing factor.

The SET PntS prompt will only appear if 20Point is selected. This allows users to bypass the 20 point set up and keep the existing values.

Press the **↑** key to choose YES or NO.

Press the **E** key to enter the displayed selection.

Press the **M** key to skip (same as selecting NO).

Press the **↑** key to increment each individual digit of the frequency for point #.

Press the **←** key to advance to the next digit.

Press the **E** key to enter the displayed frequency.

Press the **M** key to skip and keep the existing frequency.

If 0 is entered, the display will advance to the next prompt (tdec).

Press the **↑** key to increment each individual digit of the factor for point #.

Press the **←** key to advance to the next digit.

Press the **E** key to enter the displayed factor.

Press the **M** key to skip and keep the existing factor.

If 0 is entered, the display will advance to the next prompt (tdec).

PROGRAMMING FLOWCHART

(continued)

Continued From Previous Page

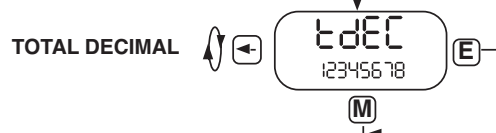

Press the ← key to step the totalizer decimal to the desired location.
Press the E key to enter the displayed decimal location.
Press the M key to skip and keep the existing location

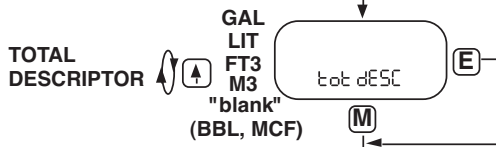

Press the ↑ key to step to the desired totalizer descriptor.
Press the E key to enter the displayed descriptor.
Press the M key to skip and keep the existing descriptor.
NOTE: When option "D" (rate per day) is ordered; selections are: GAL, BBL, MCF, M3, "blank"

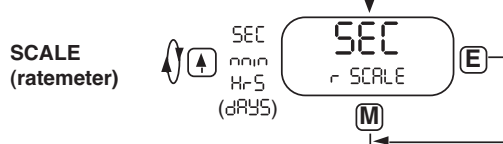

Press the ↑ key to step to the desired scale setting.
Press the E key to enter the displayed scale setting.
Press the M key to skip and keep the existing setting.
NOTE: When option "D" (rate per day) is ordered; selections are: min, SEC, dAYS

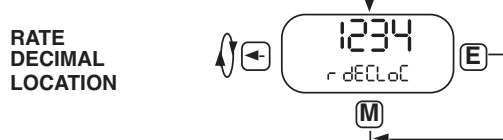

Press the ← key to step the ratemeter decimal to the desired location.
Press the E key to enter the displayed decimal location.
Press the M key to skip and keep the existing location

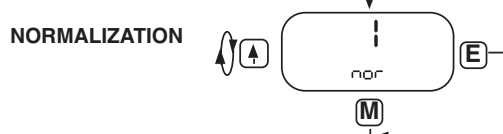

Press the ↑ key to increment each individual digit of the "nor" factor.
Press the E key to enter the displayed value.
Press the M key to skip and keep the existing value.

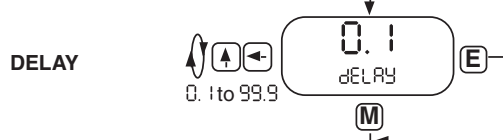

Press the ↑ key to increment each individual digit of the delay.
Press the ← key to advance to the next digit.
Press the E key to enter the displayed value.
Press the M key to skip and keep the existing value.

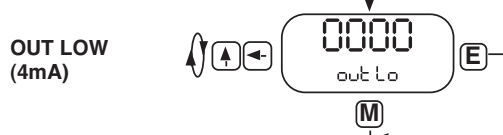

Press the ↑ key to increment each individual digit of the out low setting (4mA value). **This will only display on units with Analog Output.**
Press the ← key to advance to the next digit.
Press the E key to enter the displayed value.
Press the M key to skip and keep the existing value.

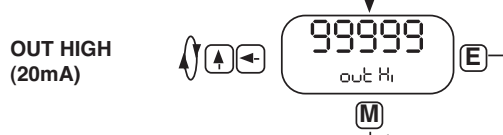

Press the ↑ key to increment each individual digit of the out high setting (20mA value). **This will only display on units with Analog Output.**
Press the ← key to advance to the next digit.
Press the E key to enter the displayed value.
Press the M key to skip and keep the existing value.

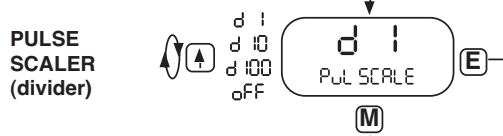

Press the ↑ key to step to the desired pulse scale divider for the pulse output.
Press the E key to enter the displayed pulse scale divider.
Press the M key to skip and keep the existing pulse scale value.

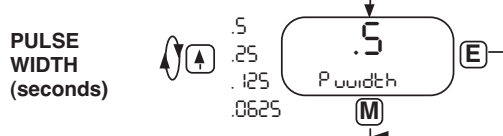

Press the ↑ key to step to the desired pulse width for the pulse output.
Press the E key to enter the displayed pulse width.
Press the M key to skip and keep the existing pulse width.
This will not display if Pulse Out is turned OFF.

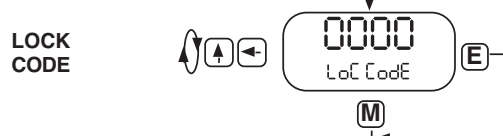

Press the ↑ key to increment each individual digit of the lock code.
Press the ← key to advance to the next digit.
Press the E key to enter the displayed value.
Press the M key to skip and keep the existing value.

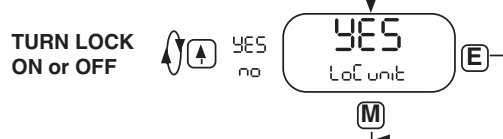

Press the ↑ key to step to the desired lock setting.
Press the E key to enter the displayed lock setting.
Press the M key to skip and keep the existing setting.

RUN MODE

OPERATION

A suitable pulse producing device or flow meter is wired to one of the three pulse inputs provided on the MRT 97-M. Only one of these inputs is used in a given application. There are no connections to the two unused pulse inputs.

Isolated magnetic pickups may be connected to terminals 1 and 2. Isolated contact closures may be connected to terminals 5 and 6. Any high level, DC pulse type may be connected to terminals 9(-) and 10(+).

Power to the unit may be provided by internal batteries or the current loop. In all cases, the internal battery will provide for continued operation in the event primary power is lost.

Once properly wired, the operation of the MRT 97-M is automatic.

The flow totalizer is updated once per second* with battery power, instantaneously with DC or loop power. If no input counts are received the unit remains in a low power state to conserve power.

The flow total may be cleared by the front panel switch sequence or by a contact closure on the remote reset terminal to circuit common.

To reset the unit from the front panel, the following key sequence is required:

Press **M** "CLr tot" will be displayed (if the panel lock is on, the display will prompt "Ent Code").
Enter the proper code to advance to the CLr tot prompt)
Press **E** To clear the total. Unit will return to operation

The flow rate indicator will measure the flow rate once every second* with battery power, 8 times per second with loop power and display the flow rate.

If the input pulses are not detected within the delay setting (0.1 to 99.9 seconds), a flow rate of 0 will be indicated.

The analog output will be scaled based on the user selected zero and full scale and the measured flow rate. The analog output is updated at the same time as the rate display.

The pulse output updates at the same rate as the total display in accordance with the instrument setup of pulse scaling.

* A large delay setting and internal math operations may delay the update rate. A faster update rate occurs when the unit is loop powered.

ERROR MESSAGES

The MRT 97-M is provided with extensive self checking which assists the user in the location of setup entry errors and in reporting malfunctions or unusual operating conditions. When an error occurs, the display will flash. Press any key to see the error message corresponding to the error that has occurred. Press any key again to acknowledge the error. (If the error can be eliminated by a change of setup values, the unit will automatically advance to the MENU so that the appropriate setup changes can be made).

Table - 2 illustrates the warning message, problem, and recommended corrective actions.

Diagnostic Error Messages Table-2

WARNING MESSAGE	CAUSE	CORRECTIVE ACTION
rRtE Er	Rate Low set higher than Rate Hi	Set Rate Hi greater than Rate Lo
FAC Err	Factor = 0	Set in correct Factor
"BAT" Descriptor	Low Battery	Replace battery(ies)
E tOtAL	Total rollover	None required
E rRtE	Rate exceeds 99999	Use lower rate dec point
E PULSE	Pulse out Overflow	Use different pulse scaler or totalizer decimal point
E FLASH	Save to flash memory failed	Write down displayed total and setup values if you are changing the battery. If total wasn't saved, it will display an arbitrary total when new battery is installed. In this case, reset the total to 0 and check the setup information.

ANALOG OUTPUT CALIBRATION

CAUTION: Performing the analog output calibration will erase all programming values. Please record all programmed values before beginning the analog output calibration

If the unit is equipped with the analog output option, the 4-20 mA has been accurately set to 4.000 and 20.000 mA by the factory. No calibration should be required.

The 4-20 mA output may be verified periodically by installing a digital milliamperemeter (DMM) in series with the analog output and simulating a full scale or over range flow rate.

If the output is out of calibration, perform the following:

Remove power and/or disconnect battery(ies). Hold down the scroll (↑) key and replace the battery. This will initialize the unit and advance to the analog output calibration mode. Connect a DMM set to read current in series with a power supply (8.5 to 30 volts DC) to TB12 (+) and TB11 (-). The output should read 4.000 ma (± 0.005). If it does not, Adjust the numbers on the display up or down until the output reads 4.000 ma (± 0.005). Press the "E" key. The DMM should now read 20.000 ma (± 0.005). If it does not, Adjust the numbers on the display up or down until the output reads 20.000 ma (± 0.005). Press "E" and the unit will return to the "RUN" mode.

Ordering Information

<u>Part Number</u>	<u>Description</u>
1-504-05-004-M	Standard MRT 97-M Rate/Totalizer
1-504-05-020-M	ATEX MRT 97-M Rate/Totalizer